

SEIKO

QUARTZ

CAL. 38SERIES (SUPPLEMENT)

PARTS LIST

The circuit block of Calibre 38 series has been supplied without the crystal oscillator except Cal. 3823 and the crystal oscillator has been supplied separately.

However, in order to facilitate repair services the circuit block will be supplied together with the crystal oscillator, and the regulation system of the circuit block will be replaced with the trimmer condenser from December, 1978.

1. New parts

Cal.	Ordinary Parts	New Parts
3803 3819	Circuit block (without crystal oscillator) 4001 838 Crystal oscillator 4151 838	→ Circuit block (with crystal oscillator and trimmer condenser) 4001 838
3823	Circuit block (with crystal oscillator) 4000 838	→ Circuit block (with crystal oscillator and trimmer condenser) 4000 838
3863	Circuit block (without crystal oscillator) 4001 831 Crystal Oscillator 4151 831	→ Circuit block (with crystal oscillator and trimmer condenser) 4001 831

Remarks: A new circuit block has the same parts number as that of an ordinary circuit block.

2. Difference between ordinary parts and new parts

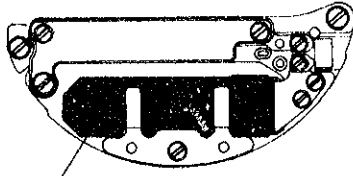
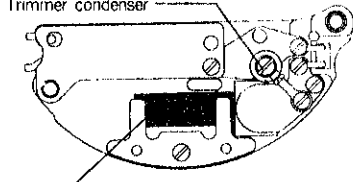
	Ordinary Parts	New Parts
Parts supply	<ul style="list-style-type: none"> ○ Circuit block ○ Crystal oscillator They have been supplied separately. (The circuit block has been supplied together with the crystal oscillator for Cal. 3823.)	<ul style="list-style-type: none"> ○ Circuit block (The circuit block and the crystal oscillator will be supplied together, but the circuit bridge plate will be supplied separately.)
Regulation system	Cal. 3823: Step variable condenser Cal. 3803 and 3819: Oscillator Regulation Condenser Cal. 3863: Oscillator Regulation Condenser or Trimmer condenser	The trimmer condenser will be used for all calibres.
Differences in appearance	 <p>Large crystal oscillator (16,384 Hz.)</p>	 <p>Trimmer condenser</p> <p>Small crystal oscillator (32,768 Hz.)</p>

3. Discernment color of the circuit block

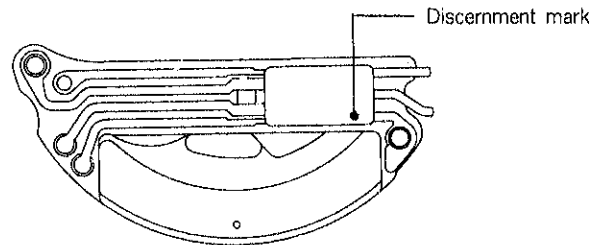

Circuit block (Back side)

Discernment mark

- Cal. 3823White
- Cal. 3803 and 3819.....Blue
- Cal. 3863No discernment mark

4. Remarks for replacing the parts

(1) Circuit block

As a new circuit block is made up together with the crystal oscillator and circuit block, both the crystal oscillator and the circuit block can not be replaced separately.

(2) Circuit bridge plate

As the new circuit block is not supplied together with the circuit bridge plate.

When replacing the circuit block, reuse the circuit bridge plate used for the ordinary circuit block.

(3) Regulation system

- Time accuracy is adjusted by turning the trimmer condenser.
- Time accuracy of all calibres should be adjusted by turning the trimmer condenser although the watch is provided with both the oscillator regulation condenser and the trimmer condenser.

MECHANICAL QUARTZ

SEIKO
Quartz

3803A & 3823A

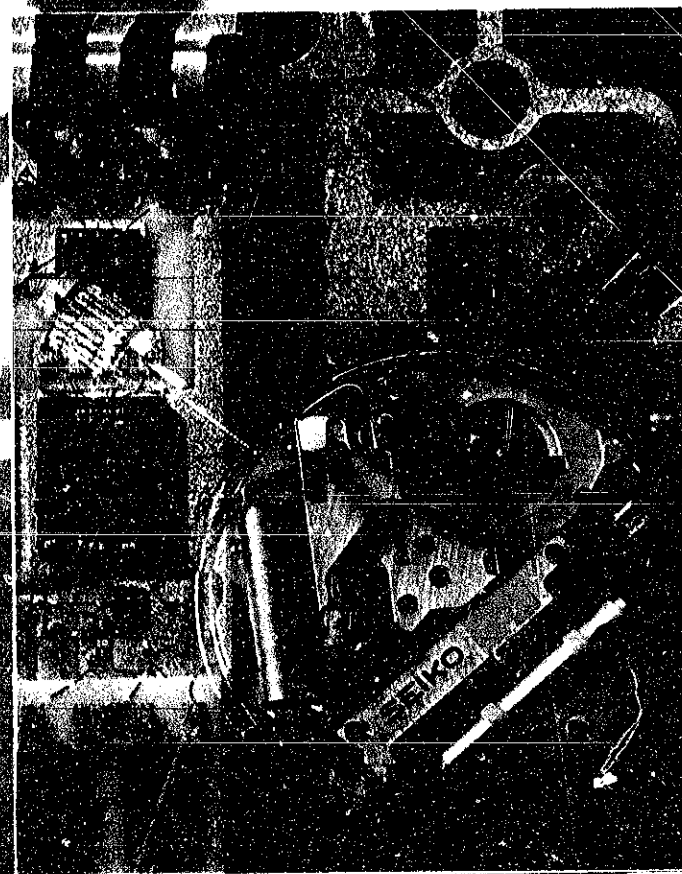

TECHNICAL GUIDE

CONTENTS

CHARACTERISTIC AND MECHANISM	1
I. SPECIFICATIONS AND FEATURES	3
1. Specifications	3
2. Features	3
II. FUNCTIONING	4
1. Structure of the movement	4
2. Outline of functioning	5
3. Functioning of electronic circuit section	5
(1) Crystal unit	5
(2) Circuit unit	6
(3) Oscillator regulating device	6
(4) Battery	6
4. Functioning of mechanical section	7
(1) Step motor	7
(2) Gear train mechanism	8
(3) Second setting and reset switch	9
(4) Calendar mechanism	10
(5) Case construction	11
III. RESETTING TIME AND CALENDAR	12
1. Resetting time	12
2. Resetting calendar	12
DISASSEMBLING AND ASSEMBLING	13
I. JIGS AND TOOLS FOR REPAIR AND SERVICING	15
II. USE OF JIGS AND TOOLS	17
1. Accuracy tester	17
2. Micro-tester	19
3. Torque output measuring apparatus (S-821)	21
Measuring method	
4. Tester	22

CHARACTERISTIC AND MECHANISM

III. DISASSEMBLING, ASSEMBLING, LUBRICATING AND CLEANING	24
1. Disassembly, assembly and lubrication	24
(1) Disassembling and assembling calendar	25
(2) Disassembling and assembling circuit block, driving coil, and gear train	26
(3) Disassembling and assembling setting mechanism.....	27
(4) Disassembling and assembling circuit block—Cal. 3803A—	28
(4) ¹ Structure of circuit block—Cal. 3823A—	29
2. Cleaning	30

CHECKING AND ADJUSTING.....	31
CHART.....	32
A. Checking output signal	34
B. Checking battery voltage	34
C. Checking battery conductivity	34
D. Checking circuit block conductivity	38
E. Checking circuit block output terminal conductivity	38
F. Checking coil block	40
G. Checking reset contact pin short circuit	40
H. Checking second jumper, turning condition of gear train and step rotor	42
I. Checking lower end-piece for third escape wheel	44
J. Checking reset condition	44
K. Checking two-second leaping and output torque	46
L. Checking rotor stator	46
M. Checking current consumption	48
N. Checking short circuit in condenser of battery protection	48
O. Checking short circuit in battery connection	48
P. Checking accuracy	50
Q. Time accuracy adjusting method	50
Testing watch accuracy	54

I. SPECIFICATIONS AND FEATURES

The SEIKO QUARTZ 3803A & 3823A boasts the following specifications and features.

1. Specifications

	Cal. 3803 A	Cal. 3823 A																						
Additional mechanisms	Calendar (day & date) Bilingual change-over system for day of week ○ Instant day and date setting ○ Second setting device ○ Electronic circuit reset switch																							
Crystal oscillator	16,384 Hz (Hz = Hertz . . . cycles per second)																							
Loss/gain	Loss/gain at normal temperature Annual rate: less than 2 minutes (Mean monthly rate: less than 10 seconds.)	Loss/gain at normal temperature Annual rate: less than 1 minute (Mean monthly rate: less than 5 seconds.)																						
Casing diameter	25.6mmφ																							
Height	5.3mm																							
Operational temperature range	-10°C ~ +60°C																							
Driving system	Step motor system																							
Regulation system	Method of the replacement of the condensers	Step variable condenser method																						
Temperature compensation device		Temperature compensation by means of special condenser																						
Battery power	Silver oxide battery (EVEREADY EPX-77) Capacity 165mAH Voltage 1.5 V Size 11.6mmφ x 5.6mm																							
Locations of jewels	No. of jewels: 7 jewels <table border="1"> <thead> <tr> <th></th> <th>Third Wheel and Pinion</th> <th>Sweep second wheel and pinion</th> <th>Step Rotor</th> <th>Others</th> </tr> </thead> <tbody> <tr> <td>Upper hole jewel</td> <td>○</td> <td>○</td> <td>○</td> <td></td> </tr> <tr> <td>Lower hole jewel</td> <td>○</td> <td>○</td> <td>○</td> <td></td> </tr> <tr> <td>Other</td> <td></td> <td></td> <td></td> <td>*○</td> </tr> </tbody> </table>					Third Wheel and Pinion	Sweep second wheel and pinion	Step Rotor	Others	Upper hole jewel	○	○	○		Lower hole jewel	○	○	○		Other				*○
	Third Wheel and Pinion	Sweep second wheel and pinion	Step Rotor	Others																				
Upper hole jewel	○	○	○																					
Lower hole jewel	○	○	○																					
Other				*○																				
	*Second jumper finger jewel																							

2. Features

- | | |
|---|---|
| <ul style="list-style-type: none"> (1) The crystal oscillator generates stabilized oscillation of 16,384Hz. (2) An ultrasmall, crystal quartz watch with casing diameter of 25.6mm. (3) One-second hand operation system by unique step motor offers high stability. (4) Device for setting time to precise second. | <ul style="list-style-type: none"> (5) Servicing of watch is easy as the movement consists of three separate sections—mechanical, coil block and electronic circuit. (6) Bilingual change-over system for day of week and instant day and date setting. (7) Battery life exceeds one year. |
|---|---|

II. FUNCTIONING

1. Structure of the movement

The circular movement consists of a circuit block including a crystal oscillator, coil block, battery, and a mechanical section of which the main component is a step motor and

a gear train. Since they are formed as individual blocks, each section can be detached separately, thus simplifying checking and adjustment.

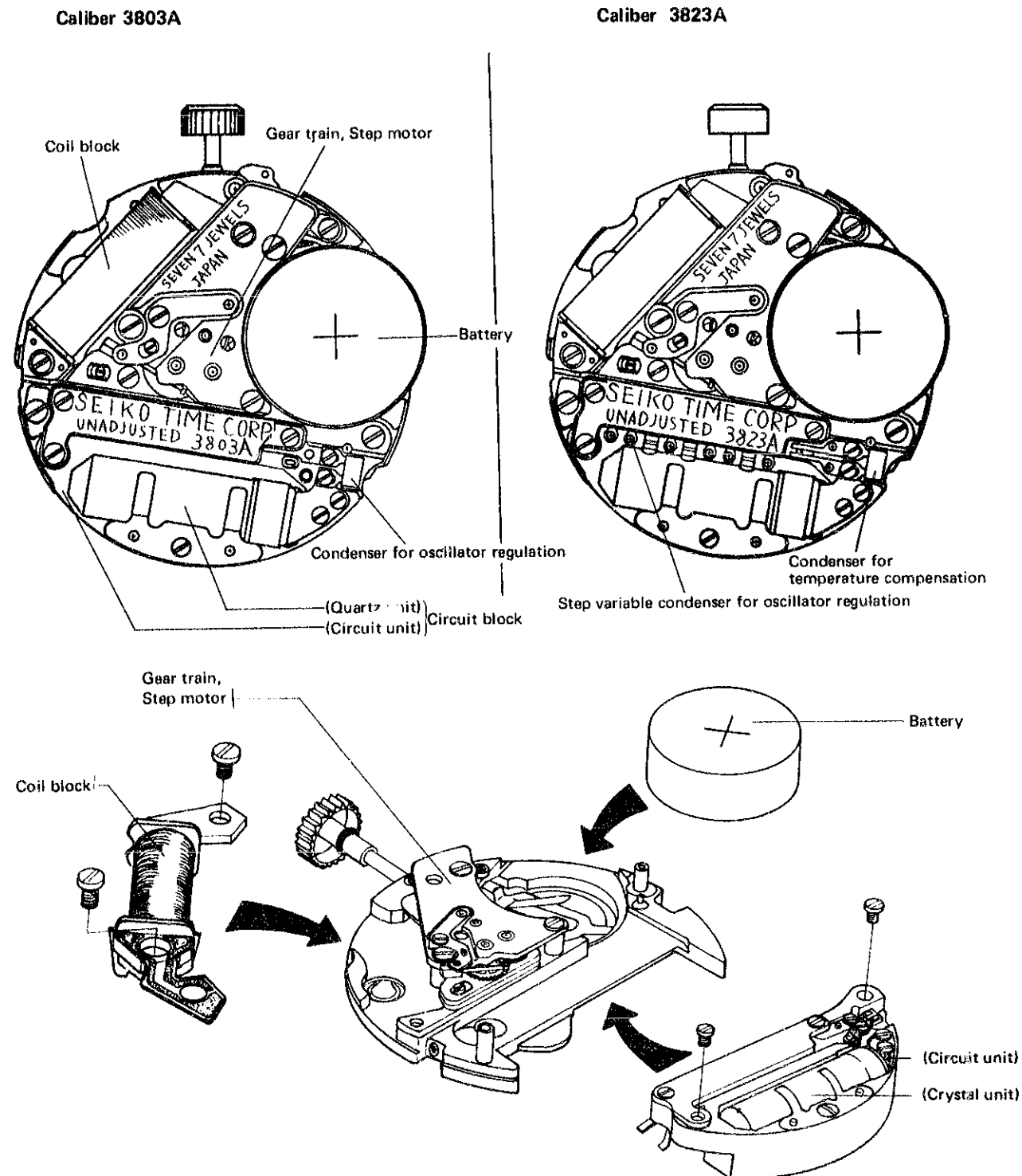

2. Outline of functioning

- (1) The crystal oscillator, built in the crystal unit, oscillates accurately at 16,384Hz.
- (2) The circuit unit receives the 16,384Hz oscillations (electronic signals) and converts them into impulses at the rate of one per second, i.e. 1/2, 1/2, 1/2
- (3) The one-per-second signals are trans-

- mitted to coil block, causing step motor to momentarily rotate once every second in 60° increments.
- (4) This rotation is transmitted to gear train thus moving the hands.

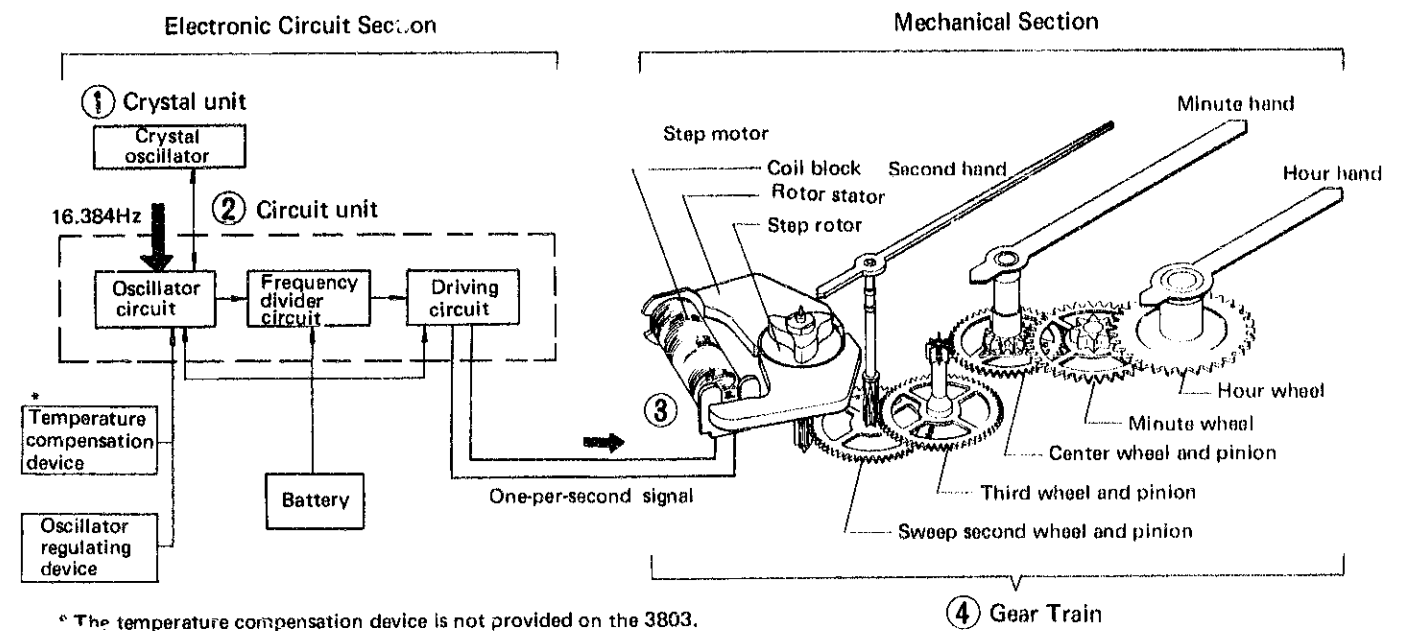

3. Functioning of electronic circuit section

(1) Crystal unit

The crystal oscillator—the “heart” of SEIKO Quartz watch Cal. 3803A & 3823A—is housed in a cylindrical case hermetically sealed to ensure stability and protection over a long period. This case cannot be opened.

To microminiaturize configuration of oscillator a unique tuning fork type is adopted. The electric current supplied through the circuit unit causes it to oscillate at highly accurate vibrations at 16,384Hz.

The highly stabilized functioning of the

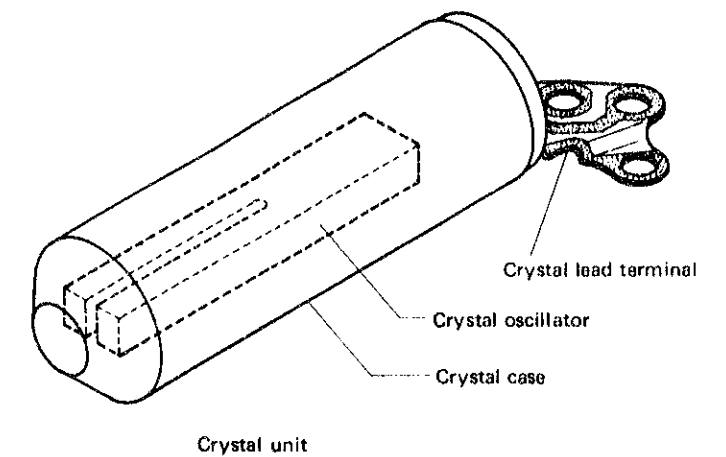

crystal oscillator is the key factor for the exceptionally high accuracy of the SEIKO Quartz watch.

(2) Circuit unit

The circuit unit is fixed with resin, centralizes all electronic circuits (oscillator circuit, frequency divider circuit, driving circuit) into one unit and has five output terminals. This circuit unit feeds the electric current to crystal oscillator causing it to oscillate at 16,384Hz and outputs these oscillations as electrical signals. Furthermore, this unit converts the 16,384Hz oscillations into one-per-second signals, i.e. 1/2, 1/2, . . . , and transmits them to step motor.

- When adjusting or repairing for Cal. 3823A, treat it as a circuit block which combines a crystal unit and a circuit unit.

(3) Oscillator regulating device

Adjustment of oscillator of the SEIKO Quartz 3803A is made by simply replacing the condenser.

That is to say, 13 different types of condensers of different capacities are provided for the purpose of oscillator regulation. Oscillator regulation is made by selecting a condenser and connecting it to both terminals of the circuit unit by means of binding screws.

The adjustment of oscillator of the SEIKO Quartz 3823A is made by simply changing the capacity of the step variable condenser.

The step variable condenser has 9 condensers of different capacities. The capacity may be optionally changed by using a combination of these condensers. The change of capacity is made by changing the numbers and the positions of the contact spring pins.

○ Checking accuracy cannot be made with conventional mechanical wrist-watch testers. It is necessary to use the QUARTZ TESTER.

(4) Battery

The electric source, a silver oxide battery (EPX-77) lasts for more than a year.

The battery maintains constant voltage except when it is near end of its service life at which time voltage drops sharply. Therefore, when watch stops or time keeping becomes inaccurate, the first step is to check battery life.

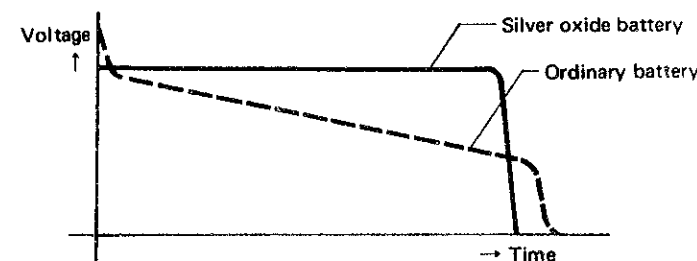
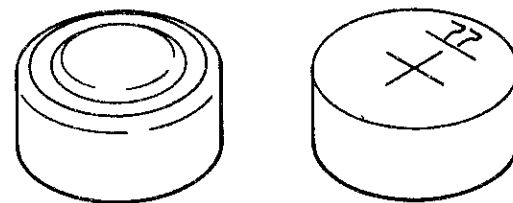
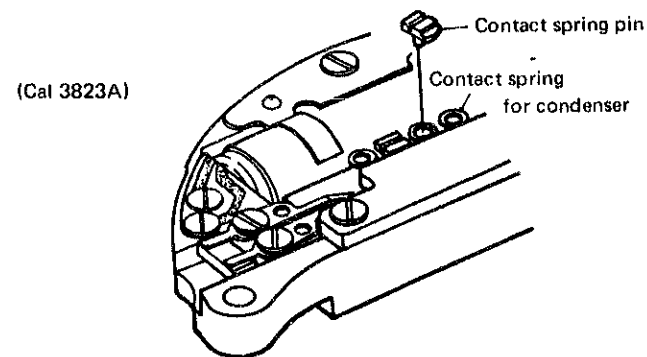
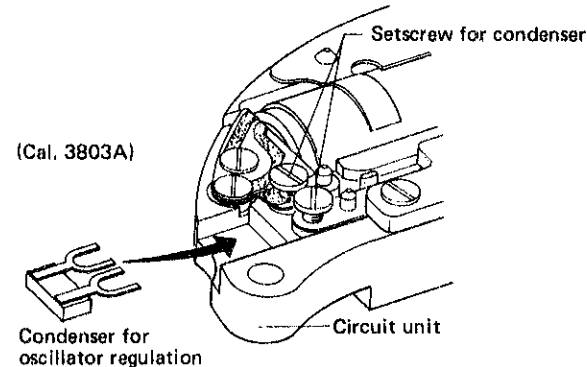
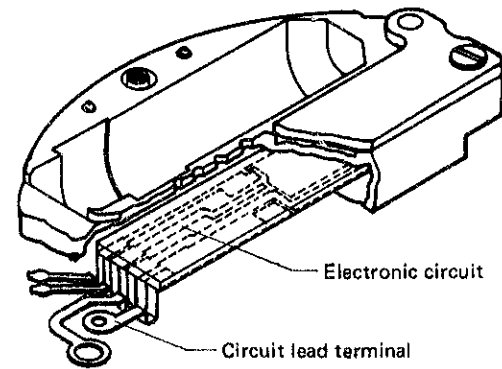

4. Functioning of mechanical section

(1) Step motor

One of the features of the watches is the SEIKO step motor which changes vibrations of crystal oscillator into rotating motion.

The step motor consists of a coil block, two rotor stators and a step rotor. The rotor stators are made of materials having high conductivity of magnetic force. The step rotor is a circular-shaped permanent magnet having six alternately imposed N and S poles.

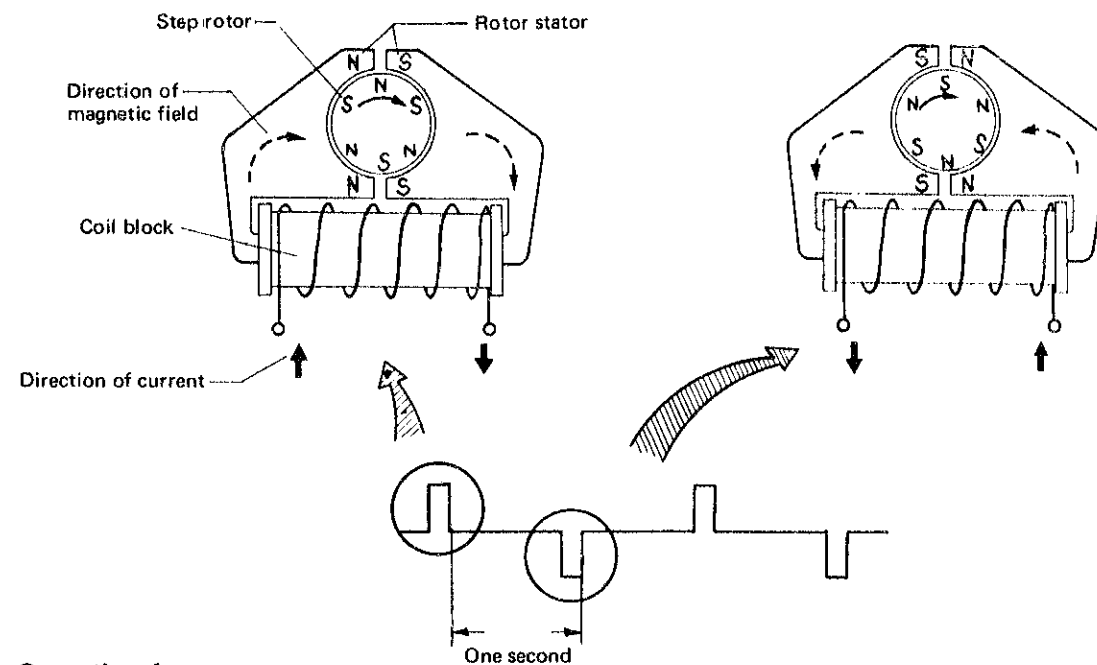
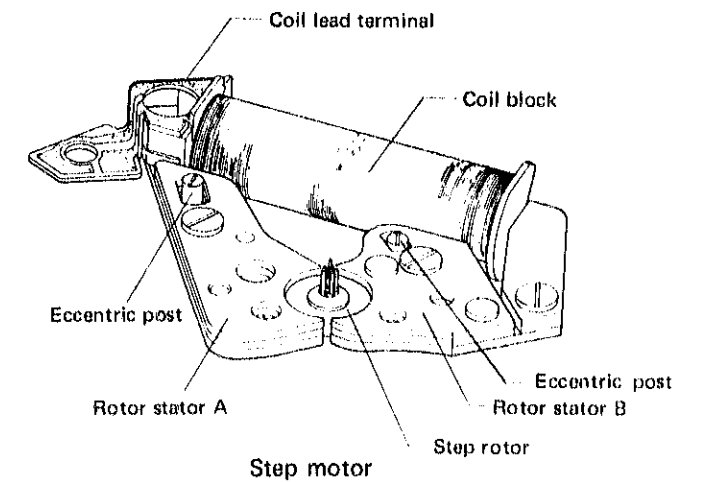

Operational sequence

(1) Current flows in coil block

The current, whose flow direction is changed once every second, is transmitted from circuit unit into coil block.

(2) Rotor stators become magnets

When current flows in the coil block, the two rotor stators become magnets and tip portions become, respectively, N and S poles.

(3) Step rotor rotations

The N and S poles of rotor stator tips and N and S poles of step rotor alternately repel and attract causing step rotor to rotate in 60° increments in a constant direction once every second.

(4) Movement of second hand

Sweep second wheel and pinion is meshed with pinion gear of step rotor. Thus, rotation of step rotor moves second hand.

(2) Gear train mechanism

The gear train features a simplified structure which also facilitates servicing. The gear train transmits the torque of step motor to indication mechanism.

This gear train contains a second hand setting device and backlash adjusting device for center wheel and third wheel pinion.

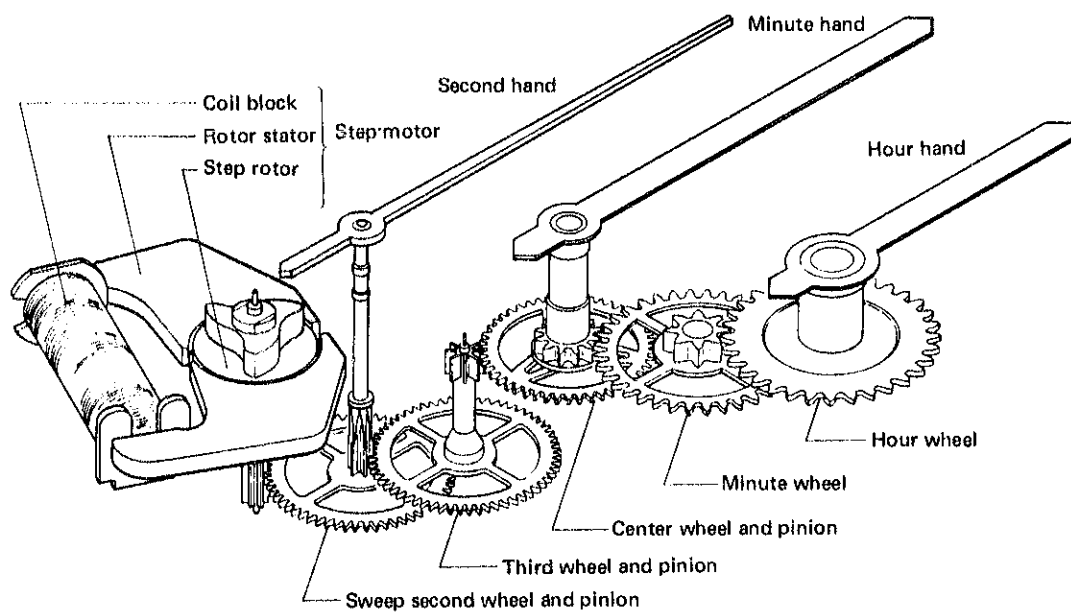
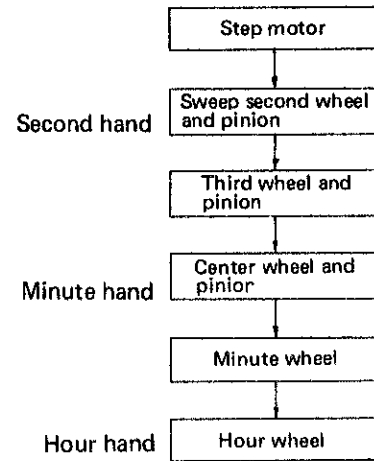

• Gear train

Transmission of step motor torque is through the following: sweep second wheel and pinion, third wheel and pinion, center wheel and pinion, minute wheel, to the hour wheel. The direction of power transmission is reverse that of conventional wrist watches.

• Second setting device

The second finger at tip of second jumper device controls position of second wheel thus permitting resetting of second hand.

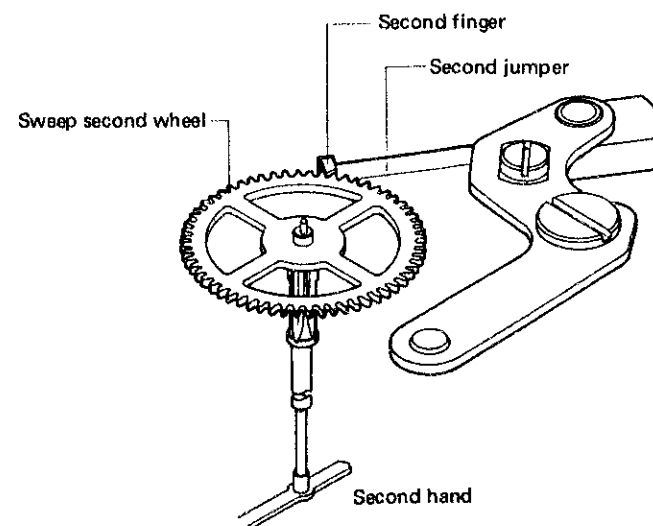

• Backlash adjusting device

When resetting the time, a backlash adjusting device is provided for center wheel and third pinion to prevent generating a time error due to interlocking backlash between wheels in the gear train.

Turning eccentric post pivoted lower end-piece of third escape wheel, causes axle of third wheel and pinion to move slightly thus adjusting amount of backlash between third pinion and center wheel.

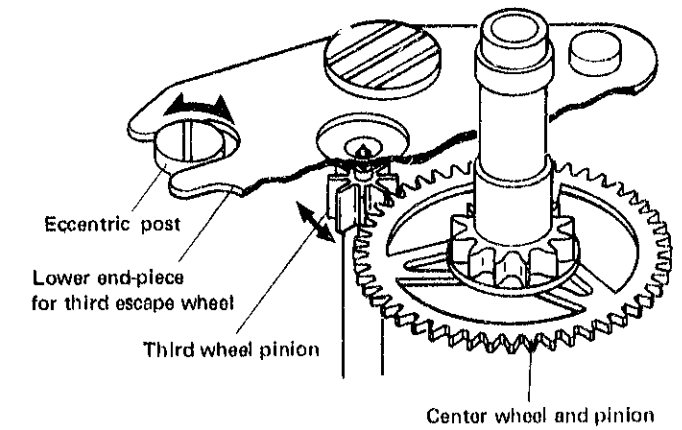

(3) Second setting and reset switch

A unique second hand setting device and a reset switch are provided for SEIKO Quartz watch. This enables "to-the-second" setting of the time.

Quartz watch. This enables "to-the-second" setting of the time.

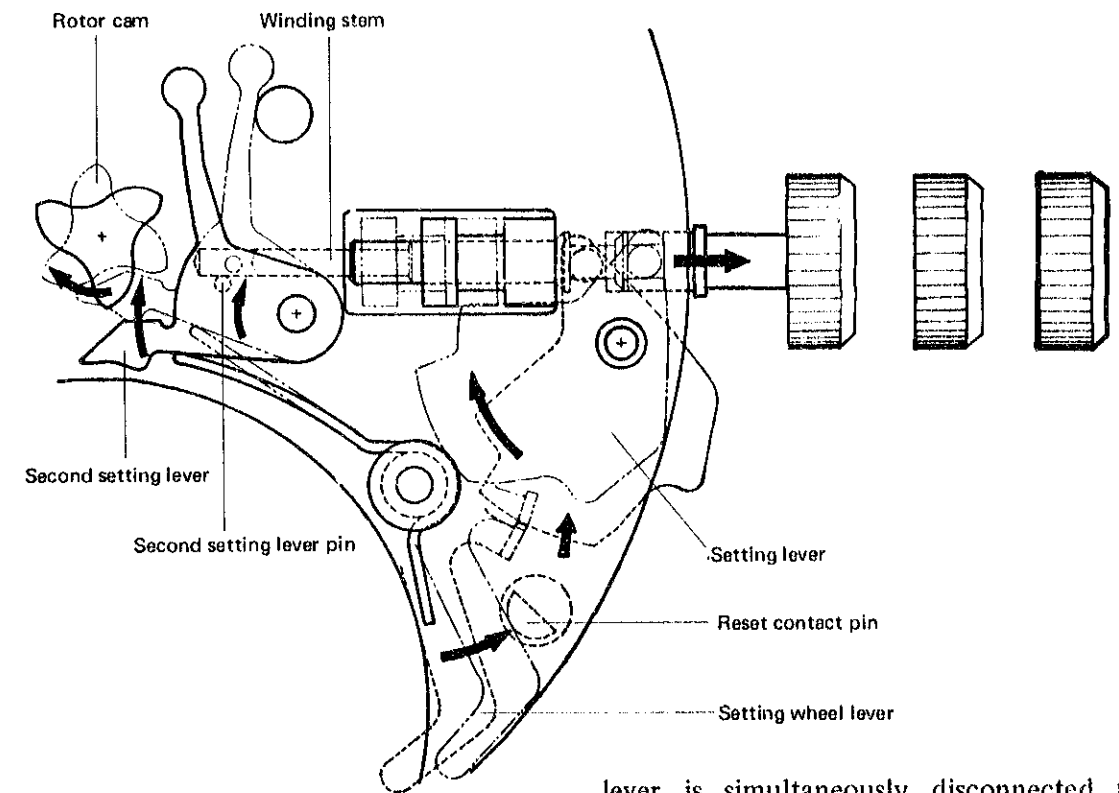

• Second setting devices

Pulling crown out to second step causes second setting lever pin to be disconnected from tip of winding stem, and second setting lever regulates rotor cam. The second hand always stops on an even-numbered second (2, 4, 6, etc.).

• Reset switch

When second hand stops, setting wheel

lever is simultaneously disconnected from setting lever and contacts reset contact pin thus engaging reset switch. When reset switch is in the ON position, watch movement is stopped.

When the watch movement is stopped, the electric current from the battery flows through the crystal oscillator and in the part of the electronic circuit, then the watch is ready to start.

(4) Calendar mechanism

(1) Time frame of date and day changes

- Date 0 hour (22:30–24:00)
- Day 01:30 hours (0:10–01:30)

Day and date setting

(2) • Crown steps

Normal position . . . Free

First step Correction of day and date

Date correction clockwise

Day correction counterclockwise

(Day and date can be changed at any time)

Second step Hand setting, reset switch and second setting

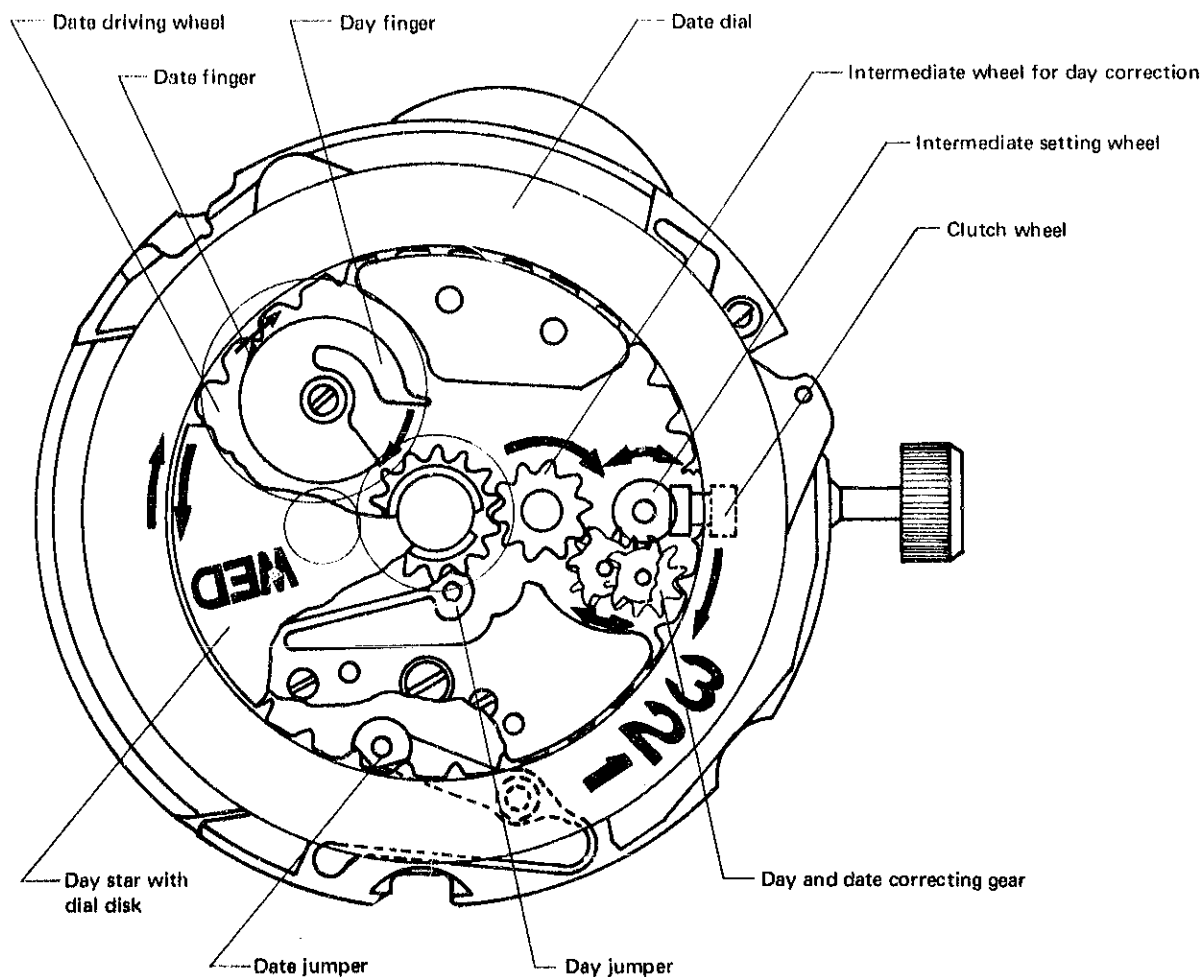

(5) Case construction

A battery lid facilitates battery replacement. The case has strong antimagnetic properties for resistance to exterior magnetic influences.

• Battery case

The section housing battery is separated from movement by an insulating cap. When replacing battery, this construction prevents dust from entering movement section.

• Antimagnetic construction

A special material is adopted for dial lower plate and case ring. Moreover, a special-grade back plate is applied to inner surface of case back, increasing movement's antimagnetic properties.

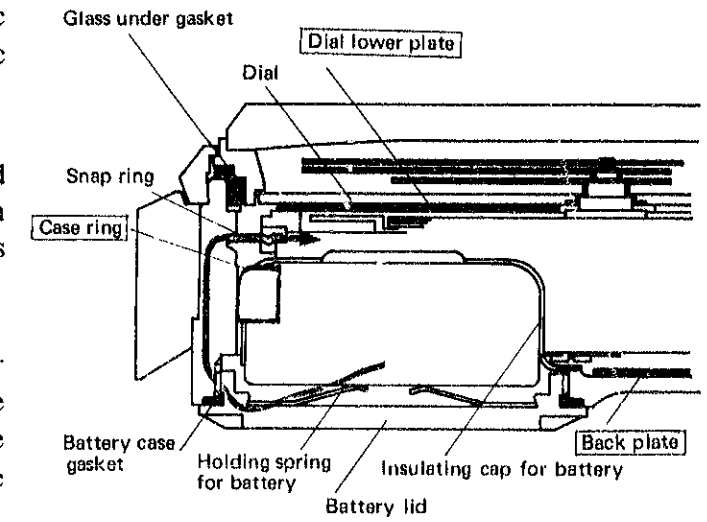

Construction of one-piece type case

The electric current from the battery (+) flows as mark → shown in diagram. Consequently, inspect the surface of the contacting part of any foreign matter.

• How to use the battery insulating cap

	Insulating cap for battery	Battery connection for plus terminal
One-piece type case	4414838	X
Screw type case	4414837	O

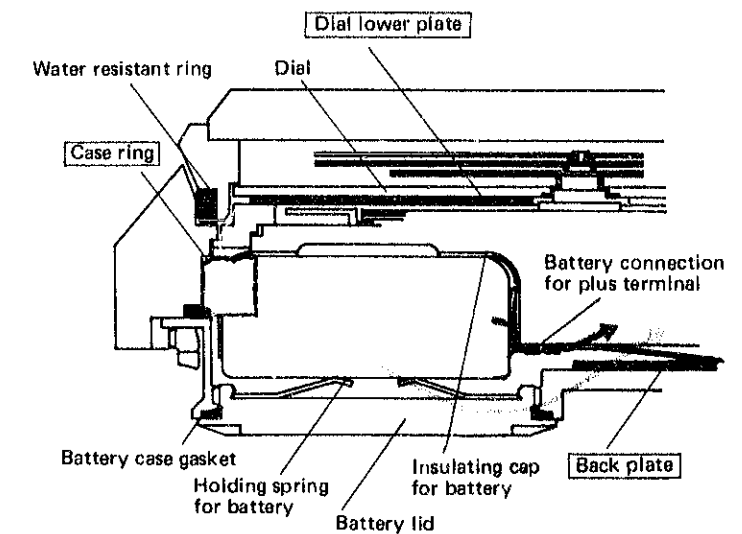

Construction of screw type case

III. RESETTING TIME AND CALENDAR

1. Reseting time

Pull crown to second click. The second hand stops on an even-numbered second (2, 4, 6, etc.).

Procedures

- (1) When second hand is at 59-second or 60-second position, pull crown to second step and stop second hand at 0-second position.
- (2) Turn the crown and set the time of hour hand and minute hand. Since the calender changes at twelve midnight, first move (turn) hands until after 12:00 O'clock to confirm if the day changes, then set the time correctly at a.m. or p.m.
- (3) Simultaneously with time signal, depress crown to start the watch. Depress crown to inntermost position

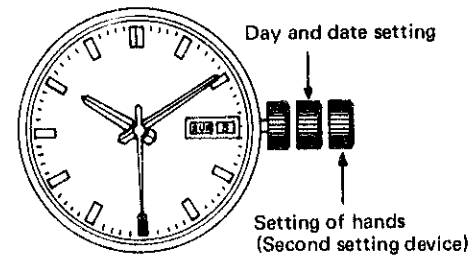

2. Reseting calendar

Pull the crown out to the first click.
Turn the crown clockwise and the date will change.
Turn the crown counterclockwise and the day of the week will change.

When setting the day of the week, a language (bilingually written) in English and Spanish for example will appear alternatively, so that select the desired one. If the setting of the calender is made when the hands are pointing to the time between 9:00 p.m. and 12:00 p.m., sometimes the calender will not change the next day. Please reset the calender outside the above times.

DISASSEMBLING AND ASSEMBLING

I. JIGS AND TOOLS FOR REPAIR AND SERVICING

For servicing and repair, the following SEIKO jigs and tools are necessary.

- Accuracy tester (Quartz Tester, Micro-test)
- Torque output measuring instrument
- Movement holder
- Movement can
- Battery holding spring

1. Accuracy testing

Quartz Tester

Used to check time accuracy (daily rates) and flow of current from circuit block.

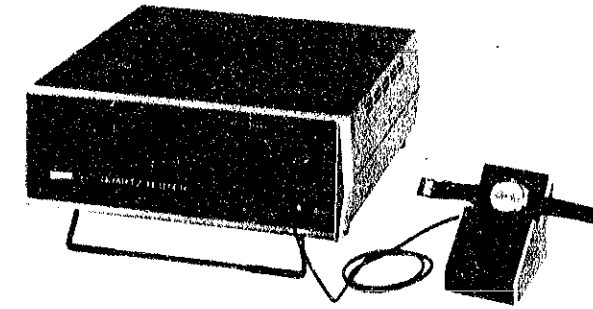

Micro-test

Used to check consumption of current and to flow voltage power constantly.

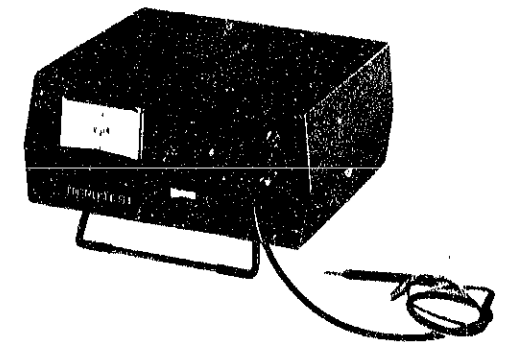

2. Torque output measuring instrument (S-821)

Used for measuring minute hand torque output.

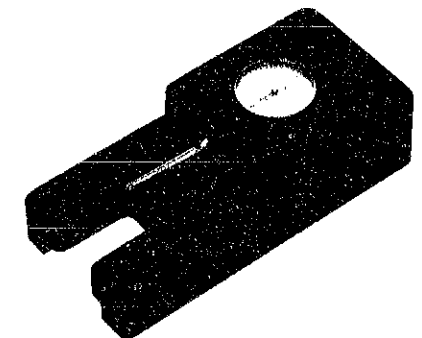

3. Tester

Used for checking battery voltage, measuring resistance and conducting conductivity test.

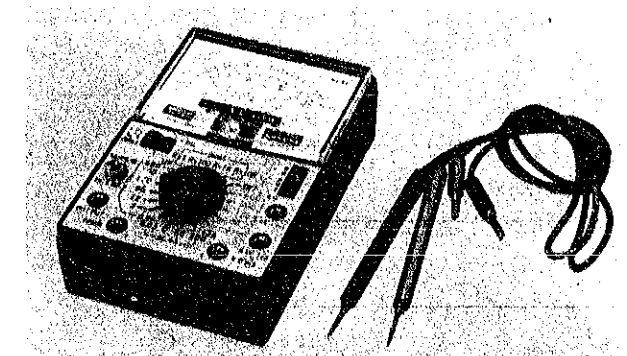

4. Movement holder

Used for disassembling and assembling the movement.

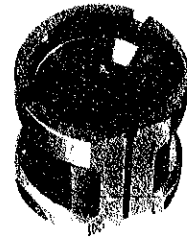

5. Set of movement holders

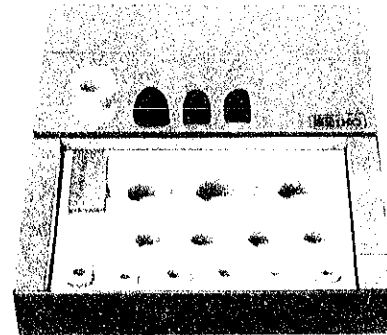

6. Movement can

Used for assembling movement in dial up.

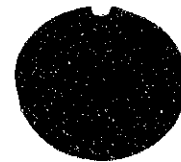

7. Battery holding spring

Used for securing battery when movement is removed from case or when case back is removed.



8. Microscope

Used for disassembling, assembling, checking, and adjusting the movement.

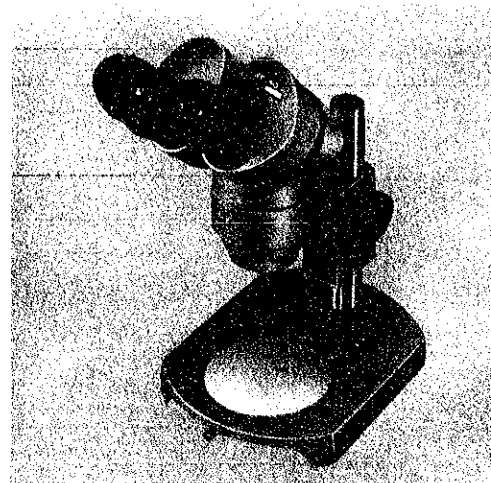

9. Others

- (1) Antimagnetic tweezers for handling step rotor.
- (2) Nonmetallic tweezers for handling battery.

II. USE OF JIGS AND TOOLS

1. Accuracy tester

Quartz tester

Used for measuring and checking the following:

- Measuring time accuracy
- Checking flow of current from circuit block

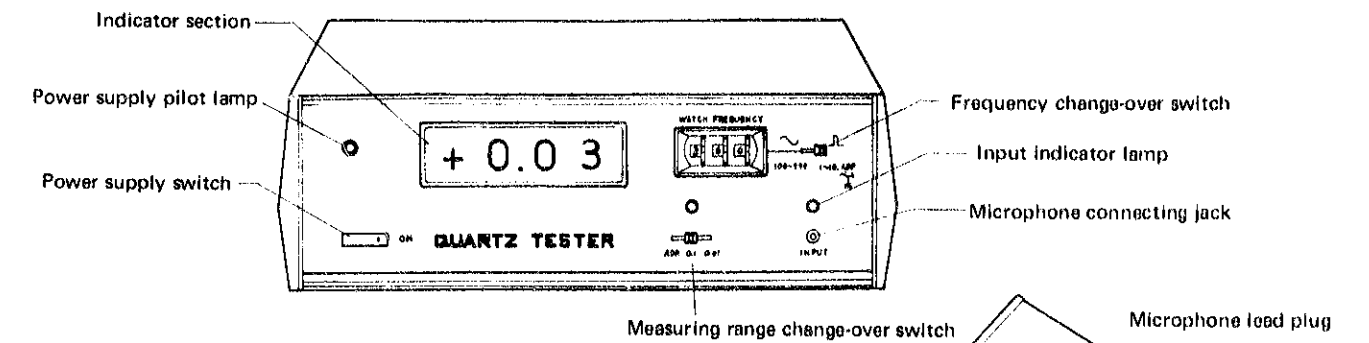

(1) Measuring time accuracy (daily rates)

<Preparation>

- ① Connect power supply cord to electric outlet.

Thirty minutes are necessary to stabilize tester.

(Connecting power supply cord causes crystal in tester to start oscillation).

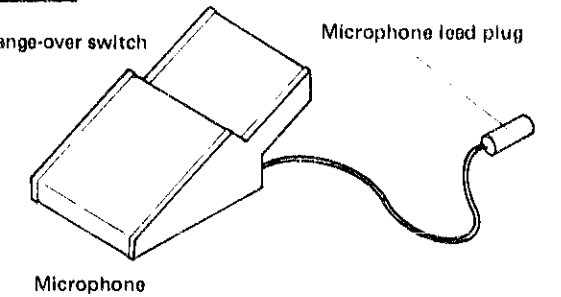

- ② Connect microphone

Insert microphone lead plug in microphone connecting jack of tester.

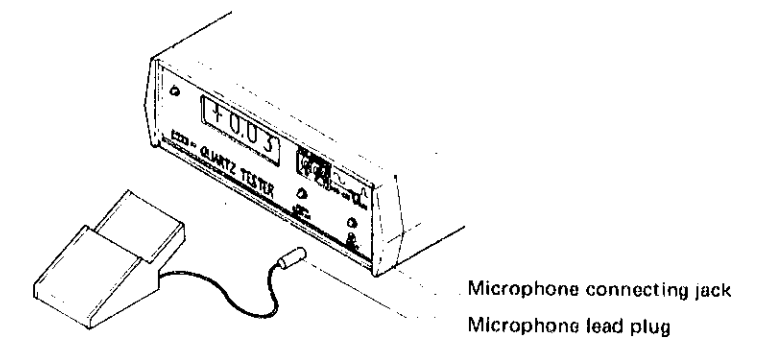

- ③ Switch power supply switch to ON position

This will illuminate power supply pilot lamp.

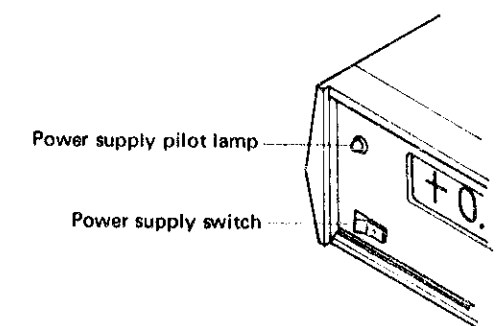

④ Set frequency change-over switch

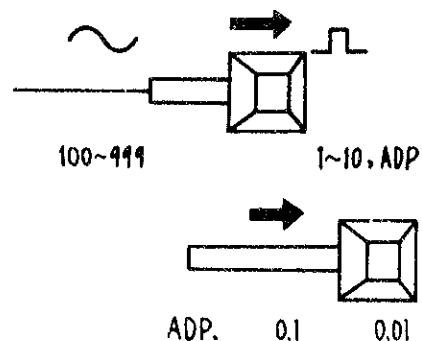

⑤ Set measuring range change-over switch

- Measuring time is ten seconds

<Measurement>

- ⑥ Place watch on microphone and confirm if input indicator lamp lights at one-second intervals.

<Note on positioning watch>

Place watch properly on microphone.

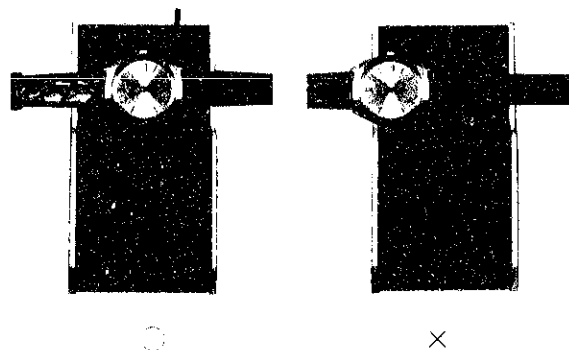

⑦ Read daily rate on indicator section.

<Note on reading daily rate>

- When daily rate is excessive there will be no indication.
- The low digit value of 0.01 second sometimes varies; however, this does not indicate a defective condition.
- Read indicated value after second indication.

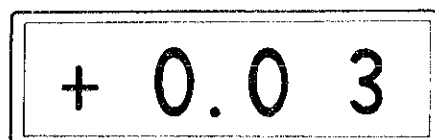

Example: 0.03 second fast

- (2) Follow these procedures when checking flow of normal current from circuit block.

<Preparation>

- ① Connect power supply cord to electric outlet.

After connecting power supply cord, immediate check can be performed without waiting for stabilization of crystal.

- ② Connect microphone

- ③ Switch power supply switch to ON position

<Checking>

- ④ Place watch on microphone.

- ⑤ Confirm if input indicator lamp blinks.

2. Micro-tester

This instrument is used for:

- Measuring current consumption
- Supplying voltage power

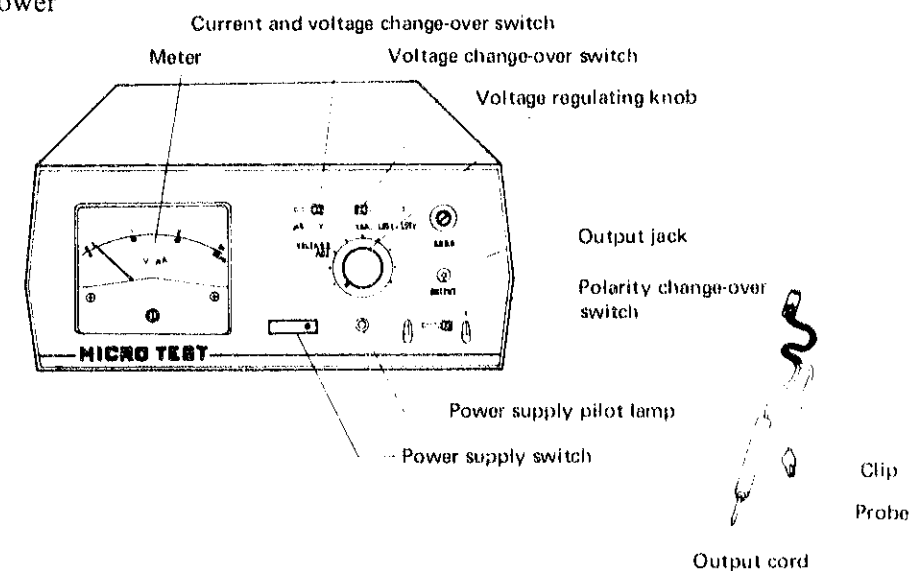

(1) Measuring current consumption

<Preparation>

- ① Connect power supply cord to electric outlet

Connect power supply cord to service jack at rear of Quartz Tester.

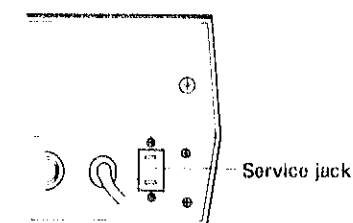

- ② Connect output cord

- ③ Set polarity change-over switch

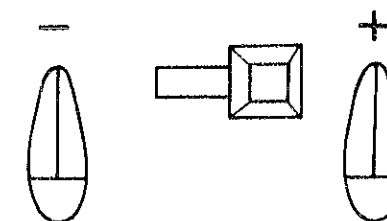

- ④ Switch power supply switch to ON position
(power supply pilot lamp will light)

- ⑤ Set voltage change-over switch to 1.55V

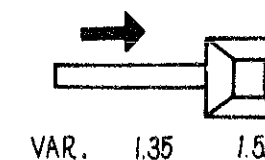

- ⑥ Shift current and voltage change-over switch to μA side.

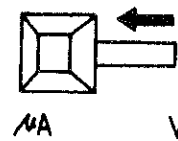

<Measurement>

- ⑦ Connect output cord to watch
- Connect clip to crown; connect probe to battery connection.

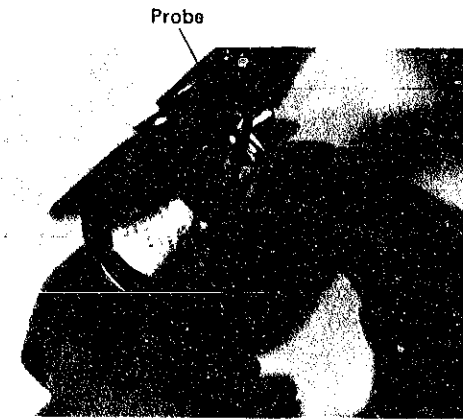

Clip

- ⑧ Read meter

(2) Suppling voltage power

<Procedures>

- ① Connect power supply cord to electric outlet
- ② Connect output cord
- ③ Set polarity change-over switch
- ④ Switch power supply switch to ON position
- ⑤ Set voltage

For 1.55V or 1.35V:

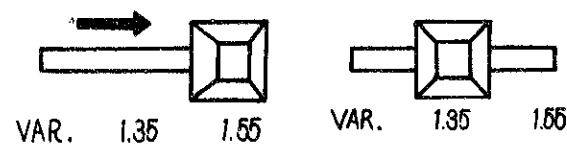

- Set voltage change-over switch to 1.55V or 1.35V.

For voltage other than 1.55V or 1.35V.

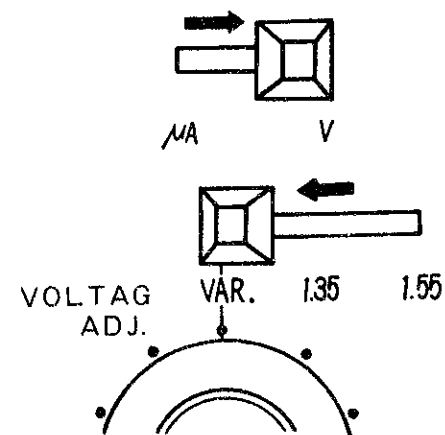

- Set current and voltage change-over switch
- Set voltage change-over switch
- Set voltage adjusting knob while observing meter

3. Torque output measuring apparatus (S-821)

Measuring method

Place operating movement on exclusive movement holder for 3803A & 3823A and set it on torque measuring apparatus to measure torque output of minute hand.

<Preparation>

① Measuring procedures

- Set movement on the movement holder. Attach minute and second hands.
- Cut tip of second hand so it does not contact terminal pin.
 - Use a minute hand having length of more than 12mm from center.

When attaching or detaching minute hand and second hand, be sure crown pulled out to second step. Otherwise, second jumper may be damaged.

- ② As shown in diagram, install movement stand on which movement was set on S-821.

- ③ Pull out crown to second step and turn minute hand until it strikes terminal pin.

- Contact minute hand to terminal pin in direction shown in diagram.
- Be careful not to contact terminal pin with dial and movement.

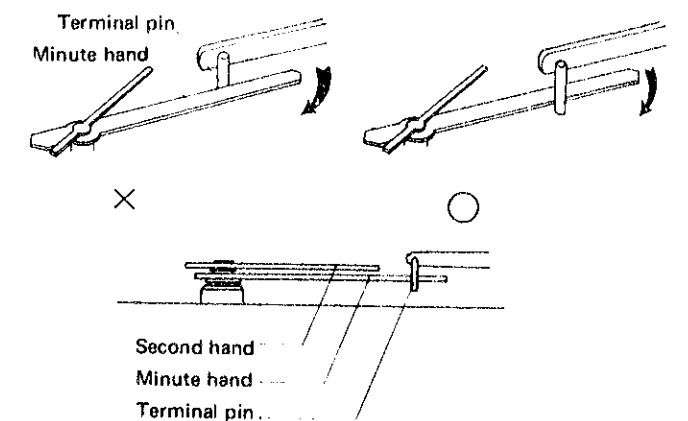
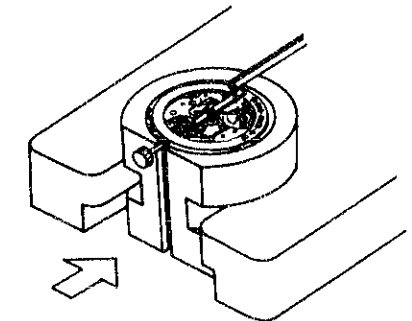
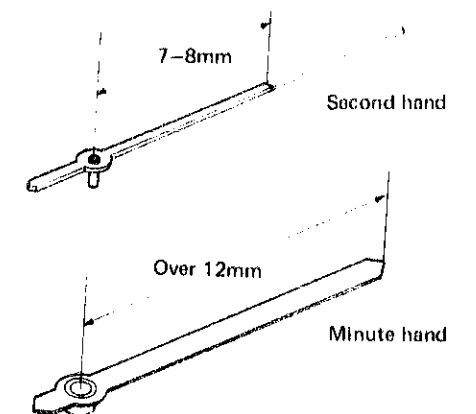
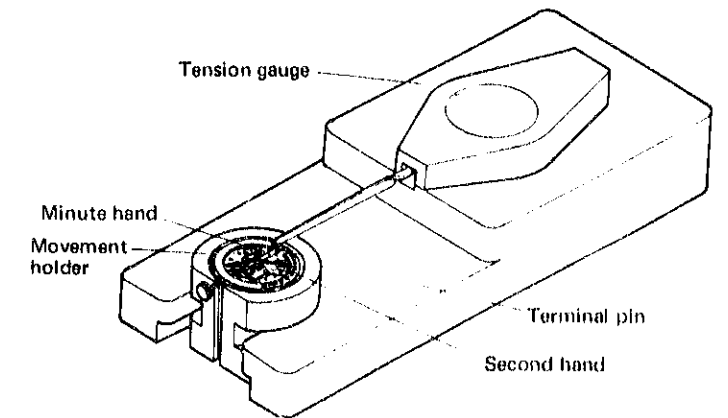

<Measurement>

(4) Push in crown and operate movement

(5) Read tension gauge indicated value when second hand comes to halt.

4. Tester

Tester is used to check battery voltage, measuring resistance and conductivity test.

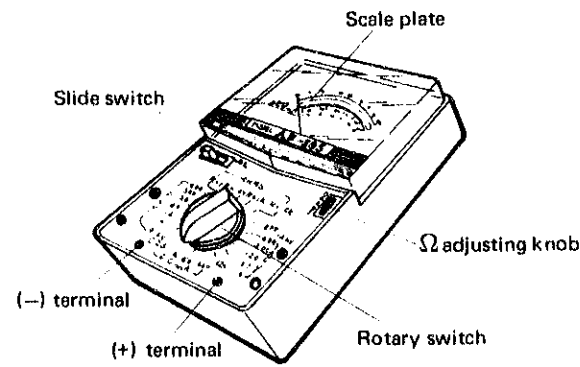

(1) Measuring battery voltage

(1) Set slide switch to (+) DC and rotary switch to DC3V.

(2) Connect red connector of probe to (+) terminal and black connector to (-) terminal.

(3) Reading

Read voltage at DCV, mA300 scale of scale plate.

Dial indicator shows mA.

Read voltage calculating 1/100

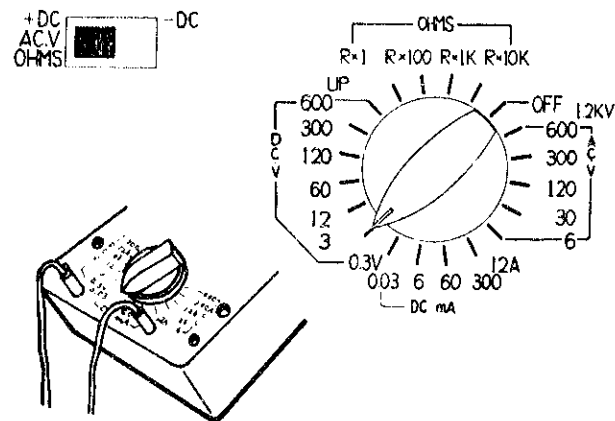

(2) Measuring resistance

(1) Set slide switch to (+) DC and rotary switch to R x 100 of OHMS.

(2) Connect red connector of probe to (+) terminal and connect black connector (-) terminal.

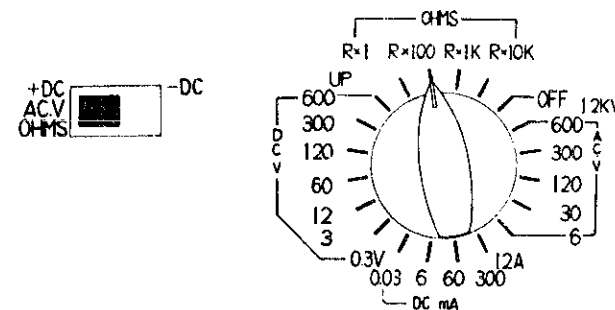

(3) Adjusting 0-ohm

Adjust so that pointer indicates 0Ω by turning Ω adjusting knob while contacting tips of red and black probes.

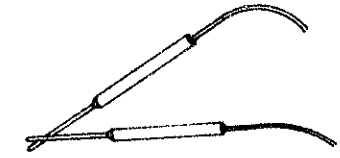

(4) Reading

Read resistance on OHMS scale of scale plate.

Read resistance calculating x 100



(3) Continuity test

(1) Set slide switch to (+) DC and rotary switch to R x 1 of OHMS.

(2) Connect red connector of probe to (+) terminal and connect black connector to (-) terminal

(3) Adjusting 0-ohm

Adjust so that pointer indicates 0Ω by turning Ω adjusting knob while contacting tips of red and black probes.

(4) Reading

Read continuity on OHMS scale of scale plate.

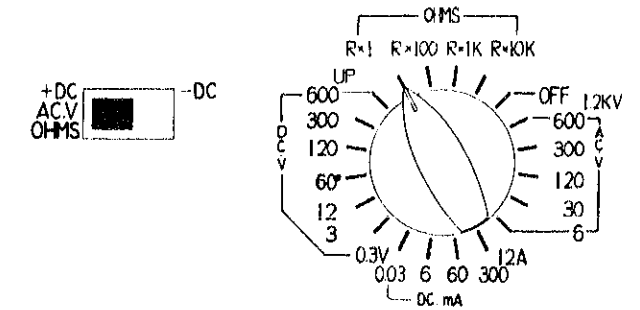

(2) Disassembling and assembling circuit block, driving coil, and gear train

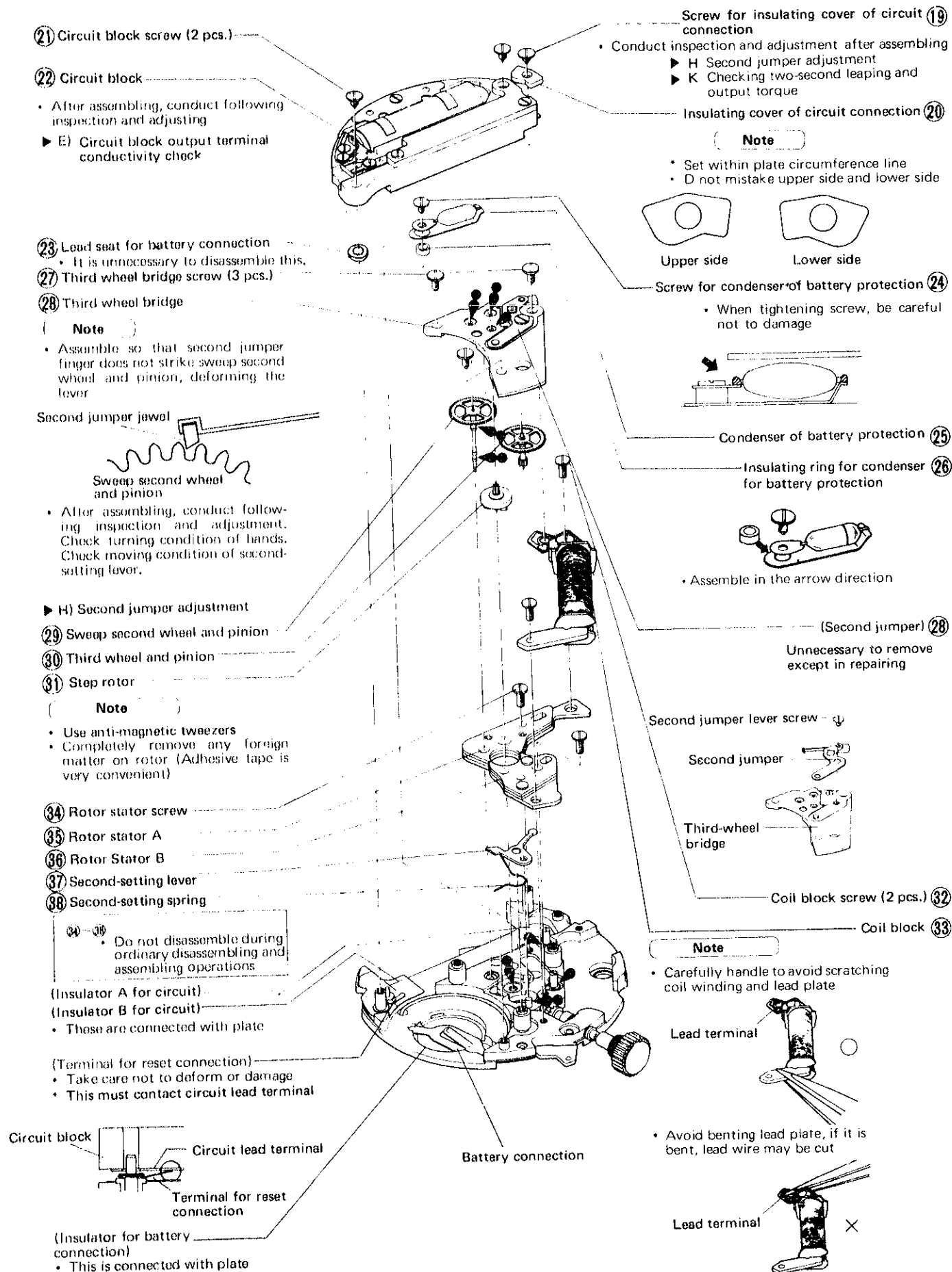

(3) Disassembling and assembling setting mechanism

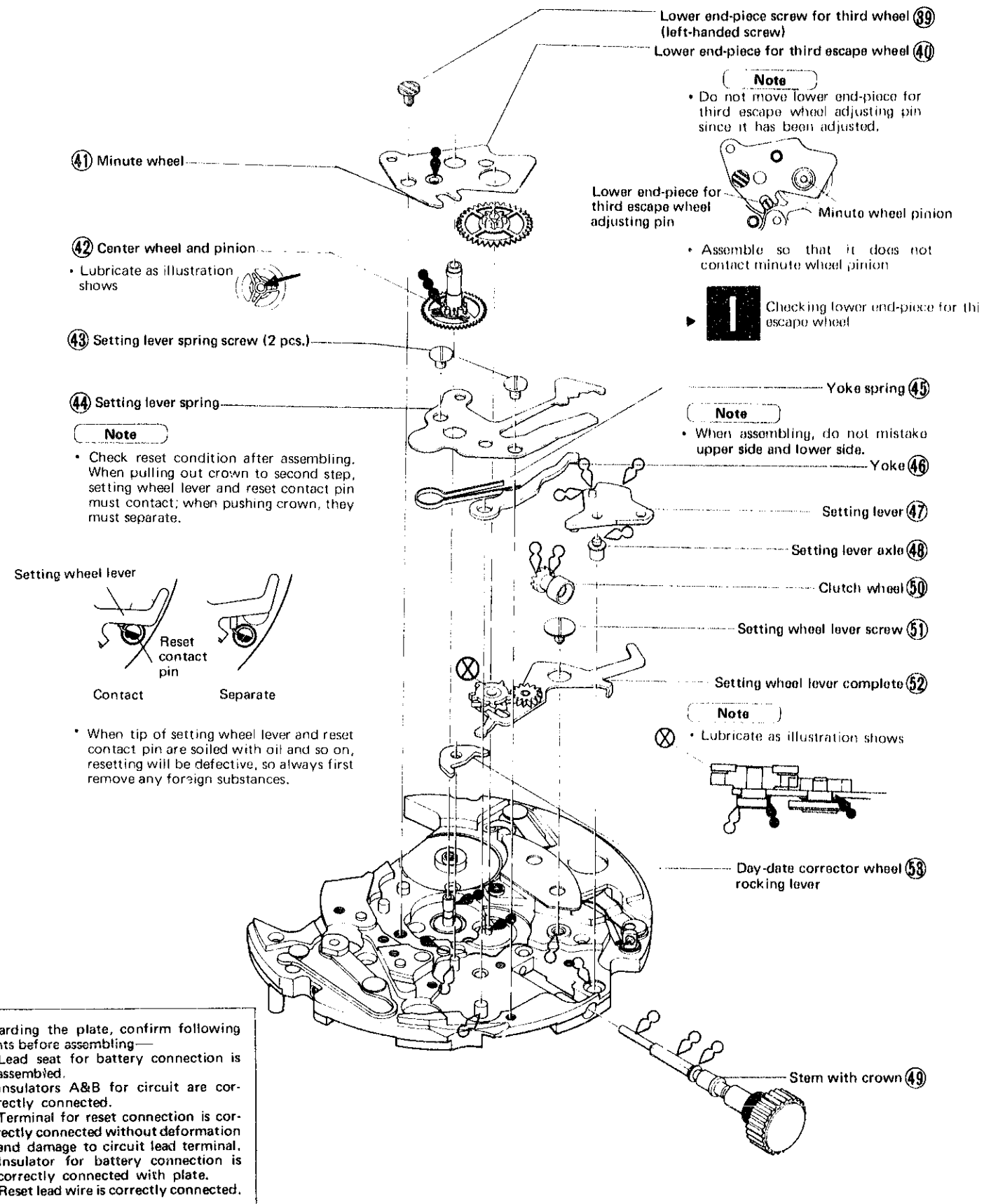

Regarding the plate, confirm following points before assembling—

- Lead seat for battery connection is assembled.
- Insulators A&B for circuit are correctly connected.
- Terminal for reset connection is correctly connected without deformation and damage to circuit lead terminal.
- Insulator for battery connection is correctly connected with plate.
- Reset lead wire is correctly connected.

(4) Disassembling and assembling circuit block—Cal. 3803A—

Circuit block consists of circuit unit and quartz unit

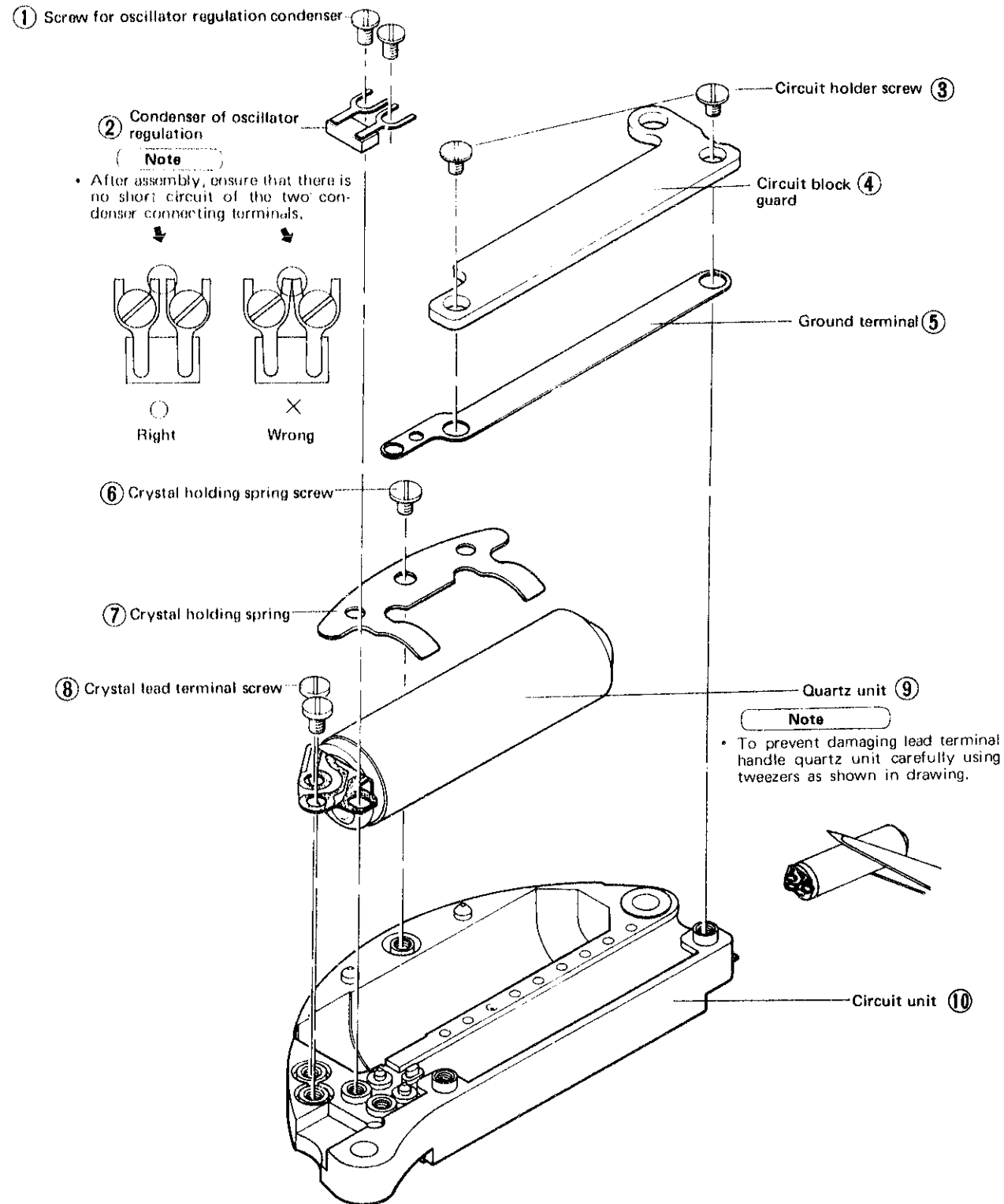

(4)¹ Structure of circuit block—Cal. 3823A—



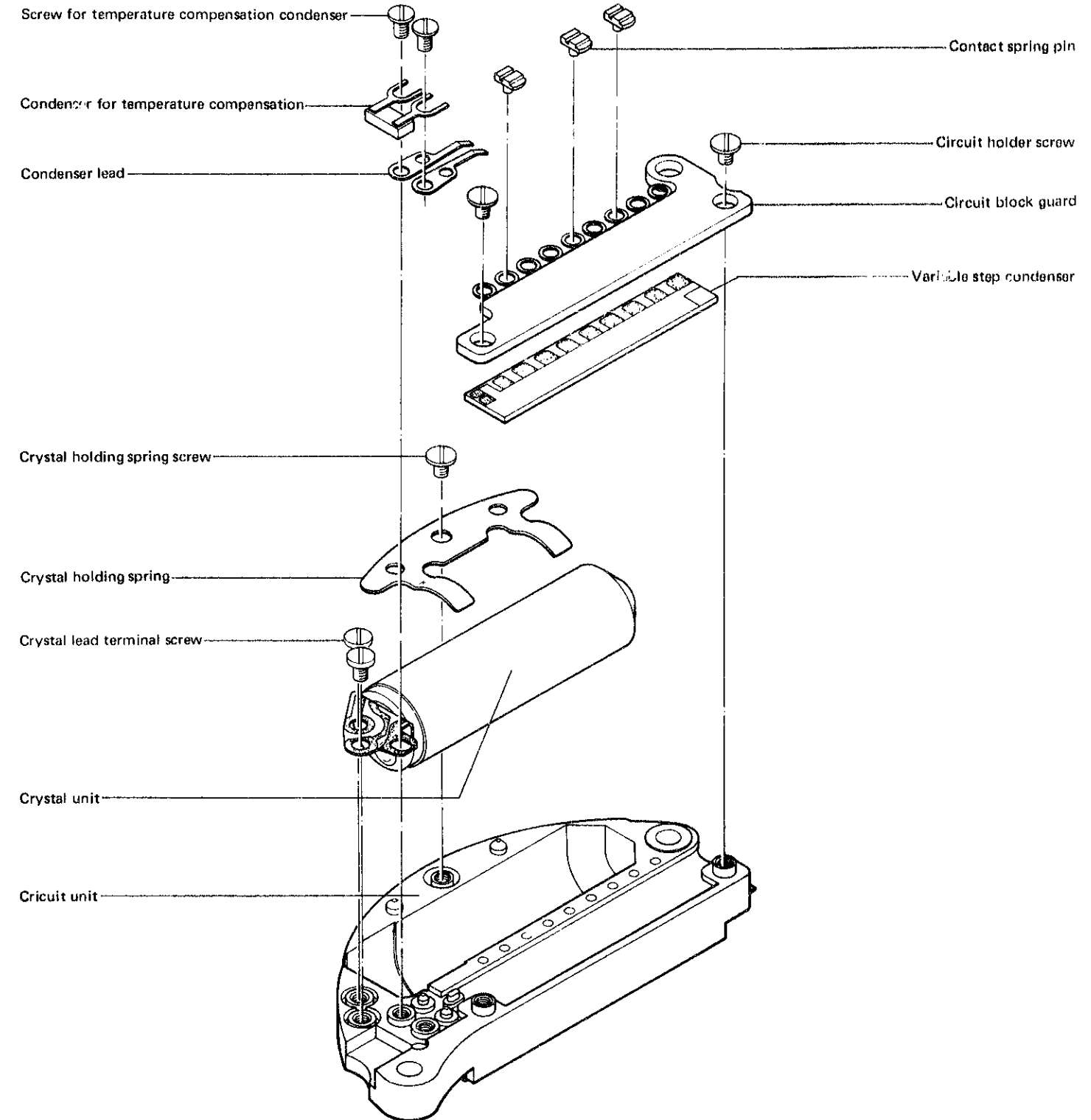



Note
Do not disassemble the circuit block of Cal. 3823.

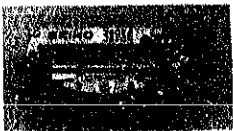

2. Cleaning

Since several special parts (electronic, plastic parts and so on) used in the SEIKO Quartz watch differ from conventional mechanical watches, use the following cleaning method when cleaning.

How to Cleaning

Name of parts	Cleaning	Drying	Solution	Remarks
① Circuit block  Coil block  Condenser of battery protection 	Do not clean			Use cloth moistened with benzine or alcohol to wipe off dirt only on conducting portion. Cold air drying
② Plate  Step rotor  Second jumper (including third wheel bridge with second jumper) 	Rinse or gently scrub with brush	Cold air drying	Benzine	<ul style="list-style-type: none"> Be careful not to remove connected portions of plate. Since step rotor is a magnet, use a clean solution. Any foreign matter which cannot be removed by cleaning should be removed with adhesive tape. Take care not to deform spring or remove finger jewel of second jumper.
③ Plastic parts	Rinse or gently scrub with brush	Cold air drying	Alcohol	
④ Parts other than above	Clean with cleaner, rinse and gently scrub with brush.	Cold or hot air drying	Benzine or trichloroethylene	

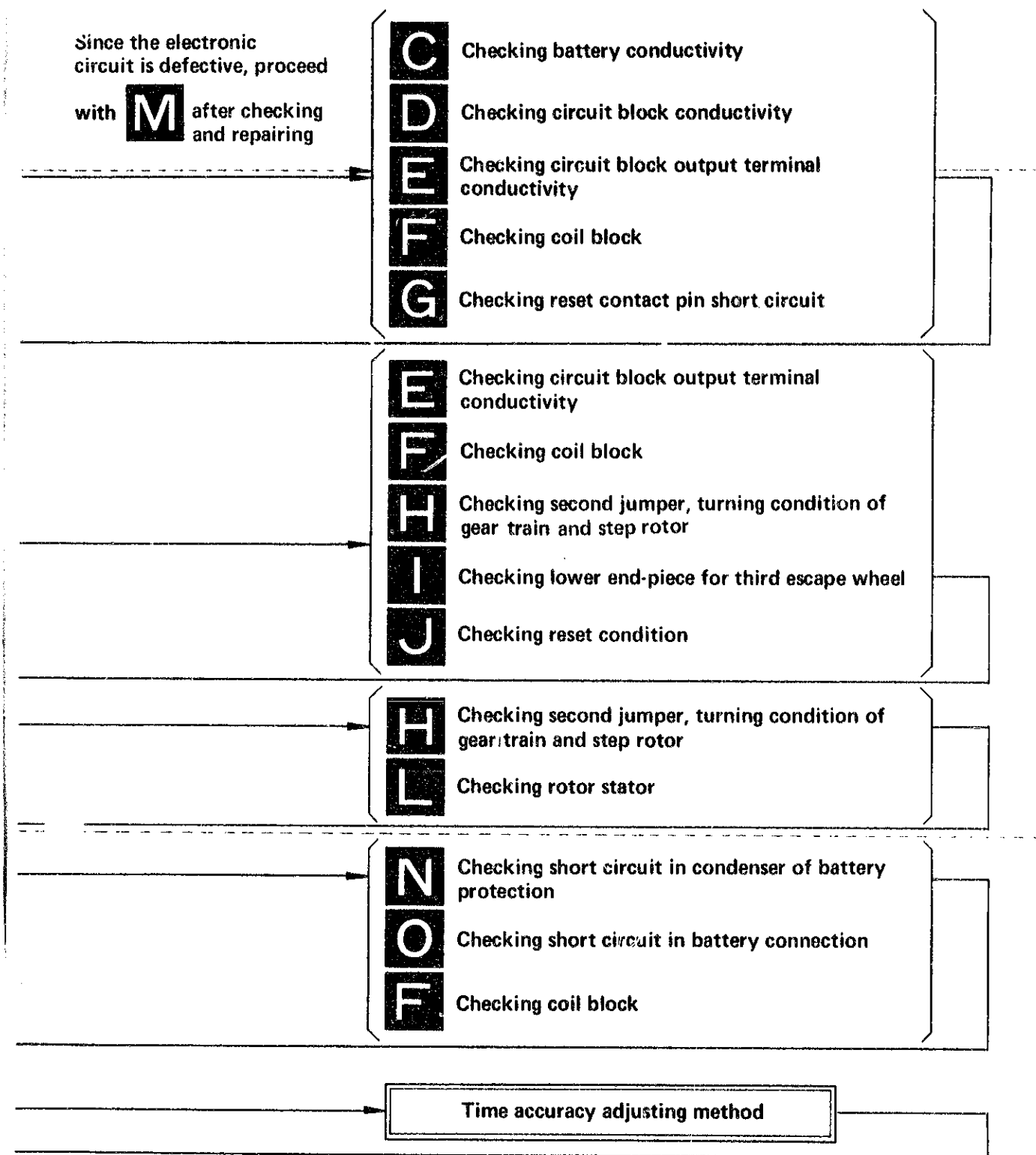
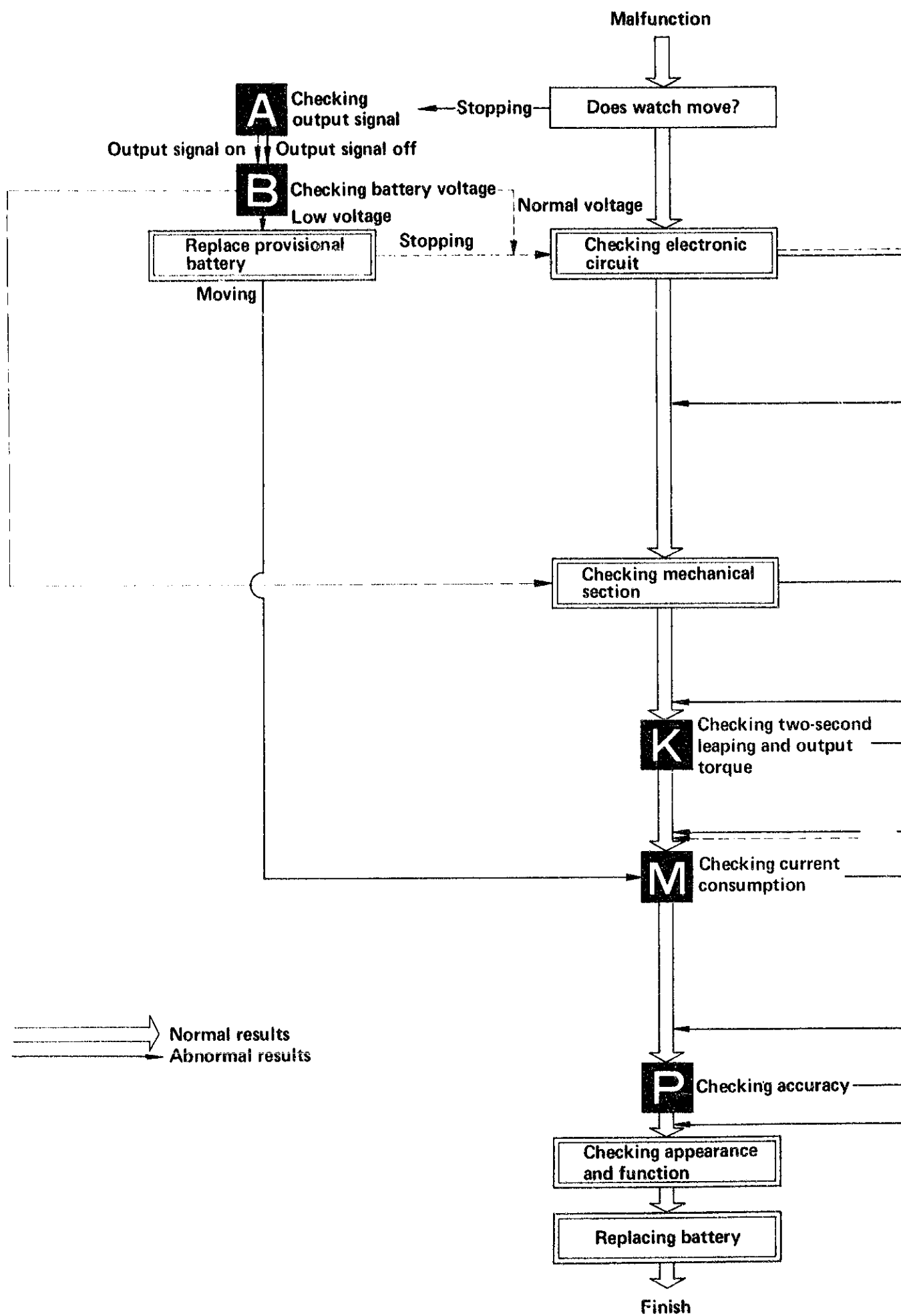

CHECKING AND ADJUSTING



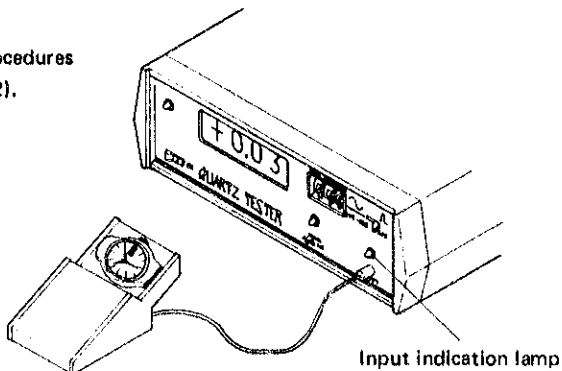
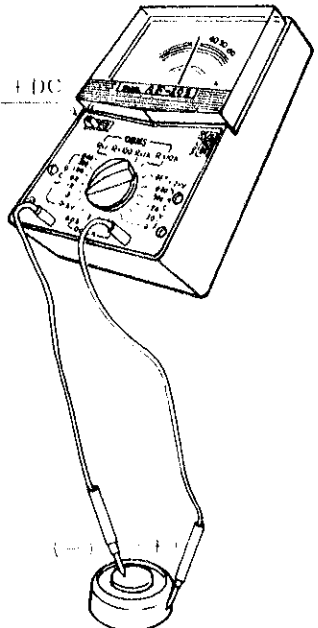
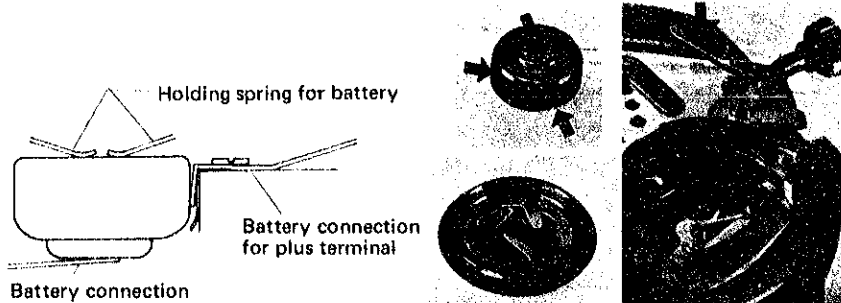

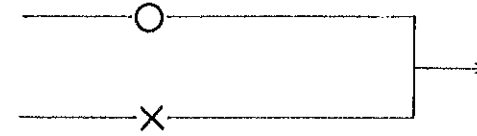
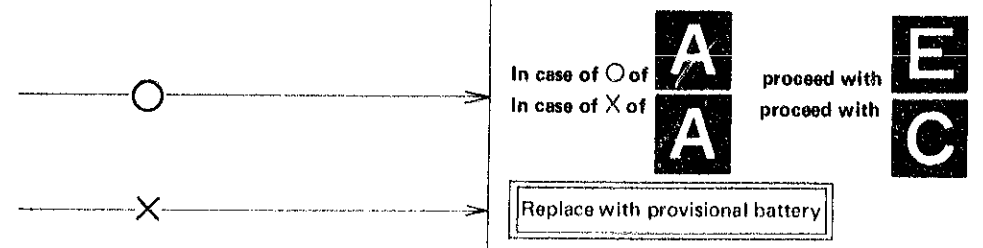
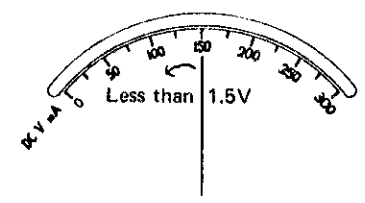
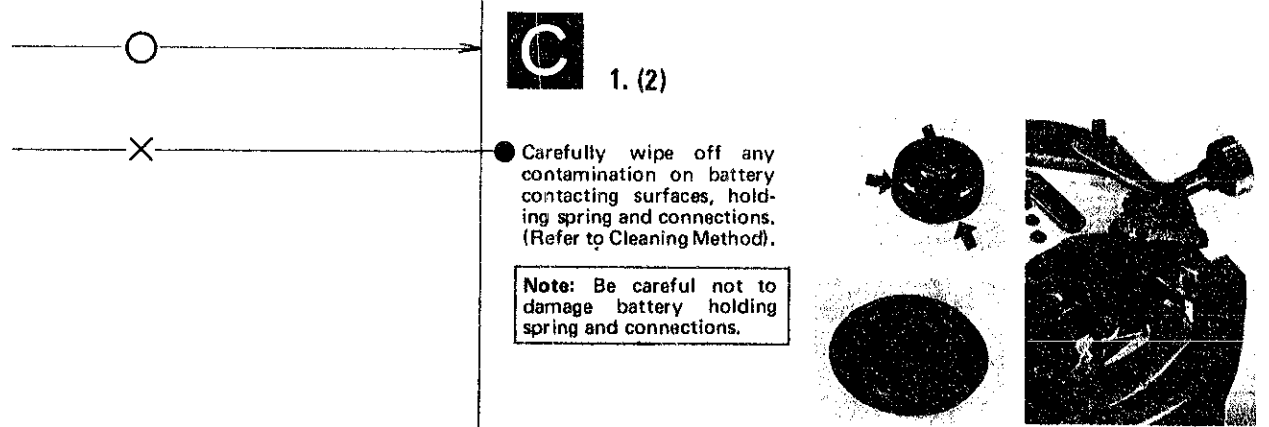
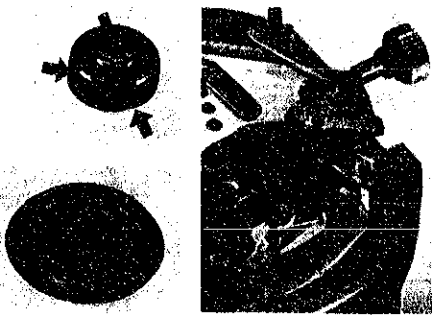
Note: After repairing, if a movement operation test is made, it will assure a finishing touch to a thorough repair job.

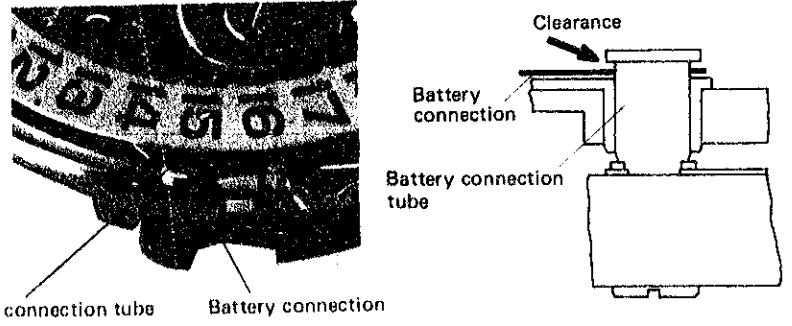
Procedures		
A CHECKING OUTPUT SIGNAL	<p>Check for output signal</p> <p>1. Set Quartz Tester Set Quartz Tester according to procedures described in Handling Methods--(2).</p> <p>2. Checking Check for output signal (Blinking input indication lamp.)</p>  <p style="text-align: right;">Input indication lamp</p>	<p>One-second blinking —</p> <p>No blinking and two-second blinking —</p>
B CHECKING BATTERY VOLTAGE	<p>Use following procedures to check battery voltage:</p> <p>1. Set tester (Refer to Tester Handling Method) Range to be used DC 3V</p> <p>2. Measuring</p> <ul style="list-style-type: none"> • Probe Red (+) Battery surface (+) • Probe Black (-) Battery surface (-) <div style="border: 1px solid black; padding: 5px; margin-top: 10px;"> <p>(Note): When handling battery, use nonmetallic tweezers or fingerstalls.</p> </div> 	<p>More than 1.5V indicates</p> <p>Less than 1.5V indicates</p>
C CHECKING BATTERY CONDUCTIVITY	<p>Use following procedures to check if battery current flow to circuit is normal.</p> <p>1. When watch is running (1) Check for contamination of battery contacting surfaces, holding spring and connections.</p>  <p style="text-align: right;">Holding spring for battery Battery connection for plus terminal Battery connection</p> <div style="border: 1px solid black; padding: 5px; margin-top: 10px;"> <p>(Note): A battery connection for plus terminal is not attached when one-piece type case of battery insulating case.</p> </div>	<p>Uncontaminated —</p> <p>Contaminated —</p>

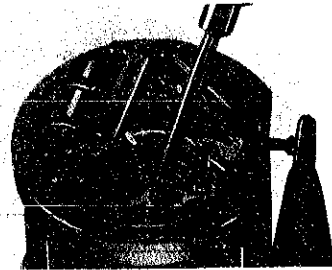
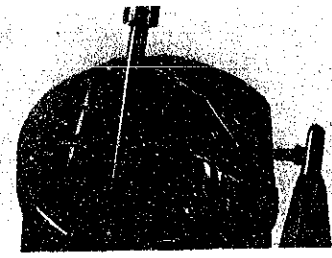
Results	Adjustment and Repair
	<p>Proceed with B</p>
	<p>In case of O of A In case of X of A proceed with E proceed with C</p> <p>Replace with provisional battery</p> 
	<p>C 1. (2)</p> <p>Carefully wipe off any contamination on battery contacting surfaces, holding spring and connections. (Refer to Cleaning Method).</p> <p>Note: Be careful not to damage battery holding spring and connections.</p> 

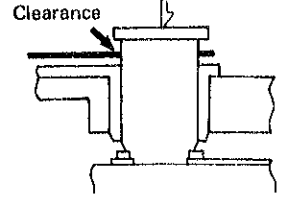
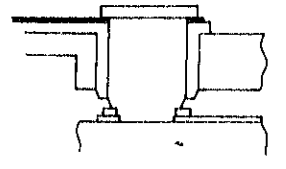
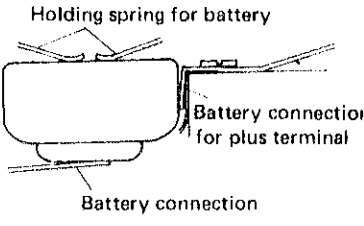
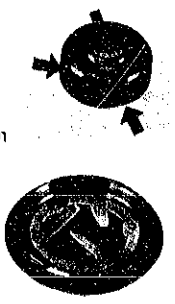
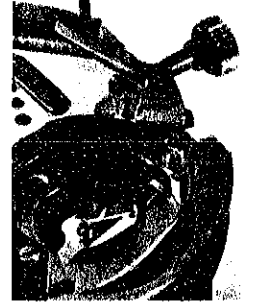
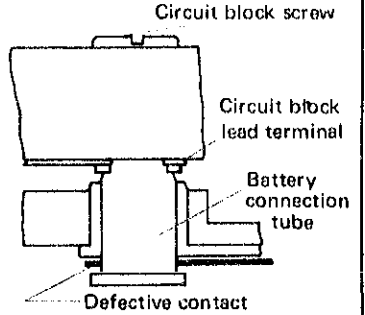
Procedures	
<p>C</p> <p>(2) Check contact of battery connection and battery connection tube</p>  <p>Battery connection tube Battery connection</p> <p>II. WHEN WATCH IS NOT RUNNING</p> <p>(1) Set Micro-test at 1.55V. (Refer to Microtest Handling Method)</p> <p>(2) Checking Clip (red) Crown Probe (black)..... Battery connection Check if the movement moves.</p>  	<p>No clearance —————</p> <p>Clearance exists —————</p>
	<p>Movement does not move —</p> <p>Movement moves —————</p>
<p>(3) Checking Clip (red) Crown Probe (black) Circuit block screw (Battery connection tube portion) Check if the movements moves.</p> 	<p>Movement moves —————</p> <p>Movement does not move —</p>

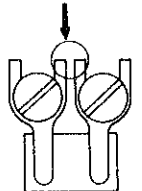
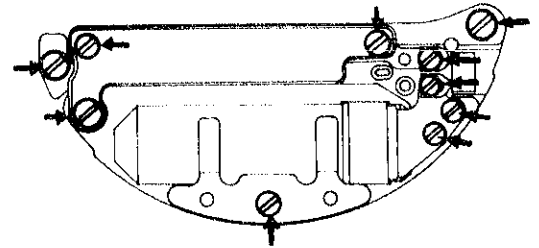
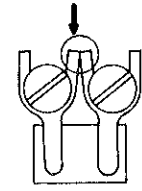
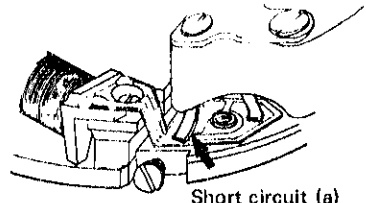
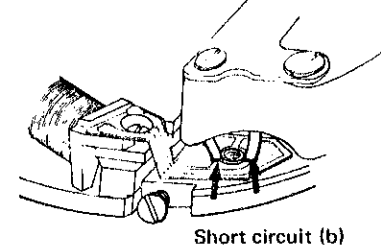
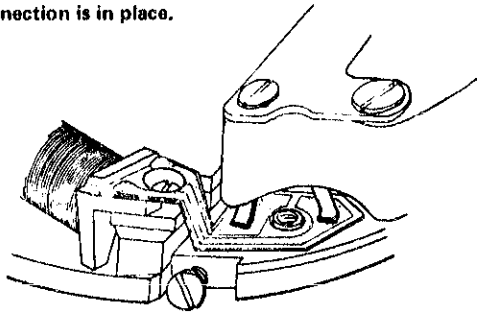

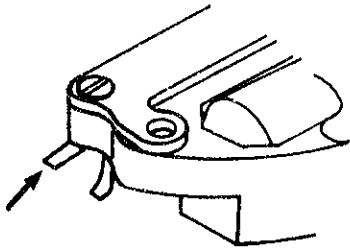
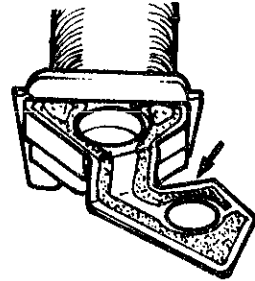



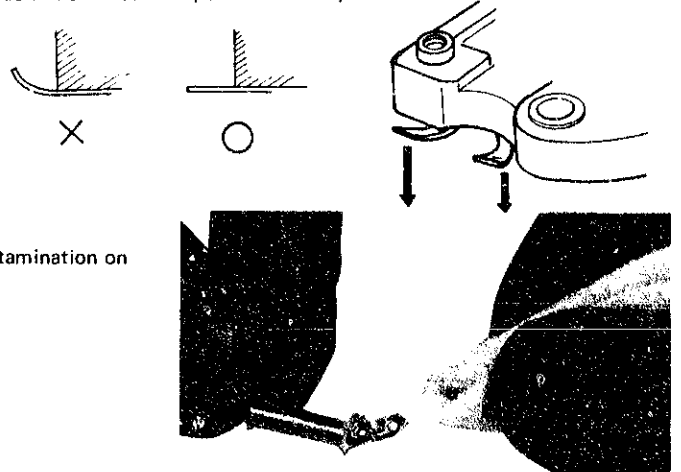

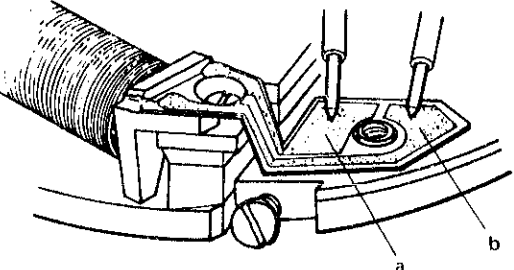
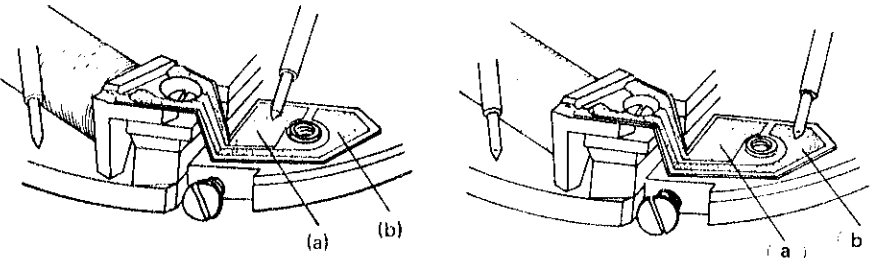
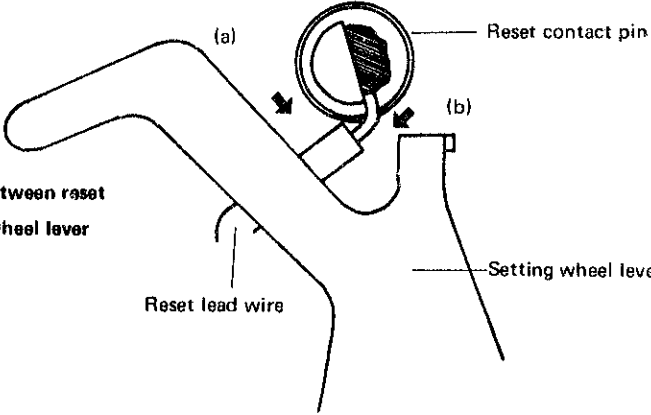
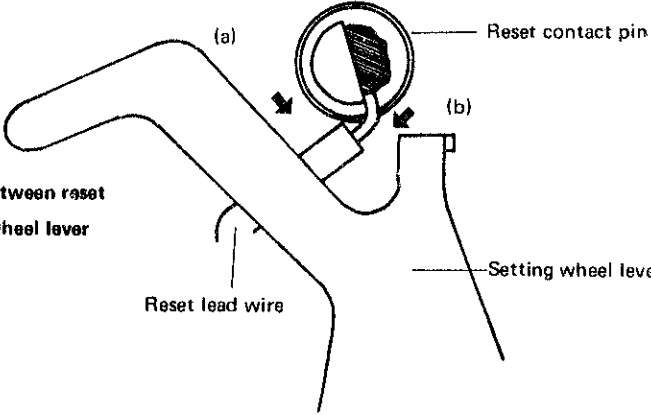



Results	Adjustment and Repair
<p>○ —————→</p> <p>× —————→</p>	<p>D</p> <p>● Restore battery connection tube portion by tapping it lightly.</p>  
<p>○ —————→</p> <p>× —————→</p>	<p>C II (3)</p> <p>● Remove any foreign substances on battery, holding spring for battery, battery connection, battery connection for plus terminal.</p>   
<p>× —————→</p> <p>○ —————→</p>	<p>● This indicates defective contact between battery connection tube portion and battery connection. Restore battery connection tube portion by tapping lightly.</p> <p>(Note): Ensure adequate tightening of circuit block screw. Inadequate tightening will result in defective contact of circuit lead terminal and battery connection tube portion.</p> 

		Procedures	
CHECKING CIRCUIT BLOCK CONDUCTIVITY	D	Check for short circuit and defective contact of circuit block conducting portion	
		<p>1. Check if lead terminals of condenser of oscillator regulation are in contact.</p>  <p>2. Check each screw (10) for possible looseness as indicated in following diagram.</p> 	 <p>No loosened screws ———</p> <p>Loosened screws ———</p>
CHECKING CIRCUIT BLOCK OUTPUT TERMINAL CONDUCTIVITY	E	Check for defective contact in circuit output terminals and coil lead terminal	
		<p>1. Check for short circuit of circuit output terminals</p>   <p>Short circuit (a)</p> <p>Short circuit (b)</p>	<p>Normal condition ———</p> <p>Short circuit (a) ———</p> <p>Short circuit (b) ———</p>
		<p>2. Confirm if output terminals are in proper contact when insulating cover of circuit connection is in place.</p>   <p>Insulating cover of circuit connection</p>	<p>Normal condition ———</p> <p>Deformed insulating cover of circuit connection ———</p> <p>Deformed circuit output terminals ———</p>
<p>3. Remove circuit block and check for terminal contamination</p>  	<p>Uncontaminated ———</p> <p>Contaminated ———</p>		

Results	Adjustment and Repair
Separate ——— ○ ———→	D 2.
contact ——— × ———→	● After loosening condenser screw, correct shape of lead terminals by using tweezers
○ ———→	E
× ———→	● Retighten screws
○ ———→	E 2.
× ———→	● Cut tip of output terminal
× ———→	● Correct deformation of terminals by using tweezers
○ ———→	E 3.
× ———→	● Replacing insulating cover of circuit connection
× ———→	● Correct the deformed circuit output terminals by tweezers
○ ———→	F
× ———→	● Remove contamination on terminals.

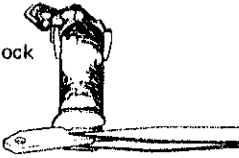

	Procedures	
CHECKING COIL BLOCK	<p>Remove circuit block and check if coil block is cracked or short-circuited</p> <p>Set tester Range at OHMS R x 100</p> <p>1. Contact probes of tester to two terminals (a and b) of coil, respectively.</p>  <p>2. Contact probes of tester to terminal (a) and plate, to terminal (b) and plate.</p> 	<p>2 KΩ ~ 4 KΩ _____</p> <p>Less than 2 KΩ _____</p> <p>More than 4 KΩ _____</p> <p>More than 10 KΩ _____</p> <p>Less than 4 KΩ _____</p>
CHECKING RESET CONTACT PIN SHORT CIRCUIT	<p>Check for short circuit of reset contact pin at normal position and first step of crown</p> <p>1. Check clearance (a) between reset contact pin and setting wheel lever</p>  <p>2. Check clearance (b) between reset lead wire and setting wheel lever</p> 	<p>Clearance exists _____</p> <p>No clearance _____</p> <p>Clearance exists _____</p> <p>No clearance _____</p>

Results	Adjustment and Repair
      	<p>F 2.</p> <ul style="list-style-type: none"> Replace coil block Remove coil block screws (2). Be sure third wheel bridge is attached. Loosen coil block screws, and remove by turning movement upside down.  <p>(Note) Be careful to avoid breaking coil wires. Hold coil block as shown in following diagram:</p>  <p>In case of Checking Electronic Circuit proceed with G</p> <p>In case of Checking Mechanical Section proceed with H</p> <p>Replace circuit block when current consumption is defective (3823A) Replace circuit unit when current consumption is defective (3803A)</p> <ul style="list-style-type: none"> Replace coil block
   	<p>G 2.</p> <ul style="list-style-type: none"> Defective action of setting wheel lever. Confirm looseners of setting wheel lever and deformation of yoke spring. <p>Proceed with Checking Mechanical Section</p> <p>When movement stops the cause is a defective circuit. Replace circuit block (3823A). Replace circuit unit or crystal unit (3803A).</p> <ul style="list-style-type: none"> By bending reset lead wire, create clearance with setting wheel lever.

I

Procedures

Check if position of second jumper is correct.
 • Use a microscope to check.

1. Checking second jumper position.

• Check meshing condition of second jumper jewel and sweep second wheel at portion A.

• Check meshing condition of sweep second wheel and step rotor pinion at portion B through the upper hole jewel for step rotor

With movement running check entire circumference of sweep second wheel

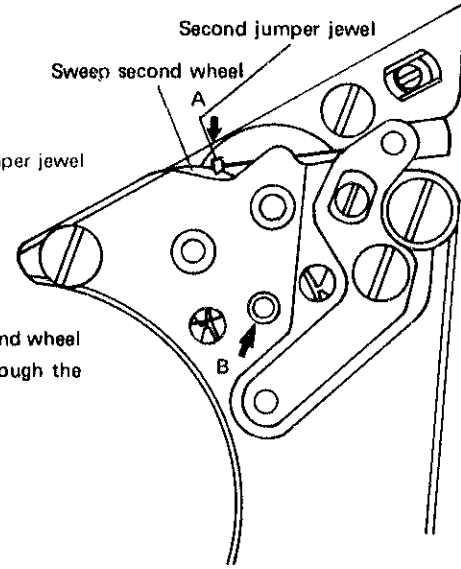

2. Checking angle of second jumper jewel

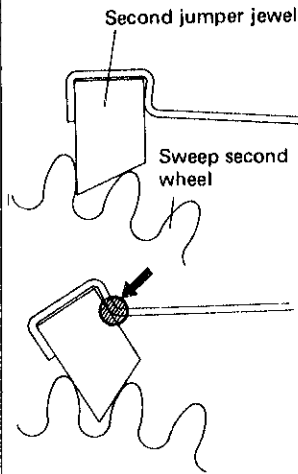

3. Checking height of second jumper jewel

Check if A is more than 2/3 the thickness of sweep second wheel B.

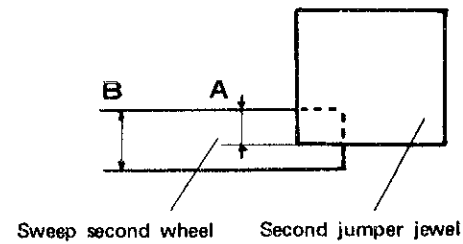

Normal condition ———

Defective condition ———

More than 2/3 ———

Less than 2/3 ———

Results

Adjustment and Repair

○ ———→

× ———→

H 2.

- Adjust by turning tail portion of second jumper or eccentric pin.
- Adjust by gently turning tail portion of second jumper.

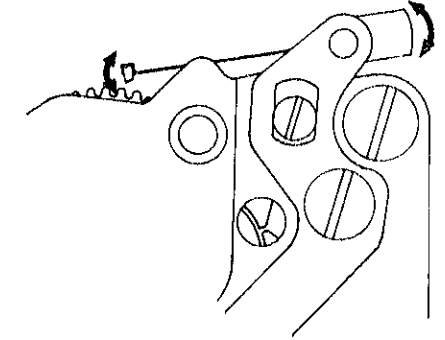

- Adjust by turning eccentric post after loosening second jumper screw

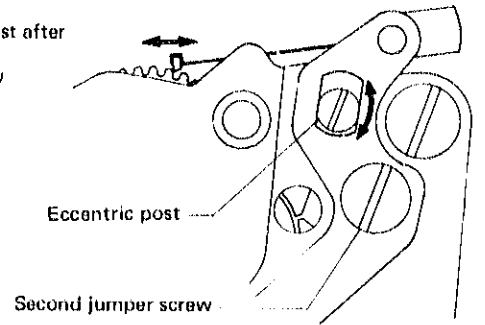

○ ———→

× ———→

H 3.

- Correct inclination of jewel by bending arrow-marked portion with tweezers.

○ ———→

○ ———→

- For mechanical section check, proceed with

turning condition of gear train and step rotor

- For defect of checking 2-second leaping and output torque, proceed with









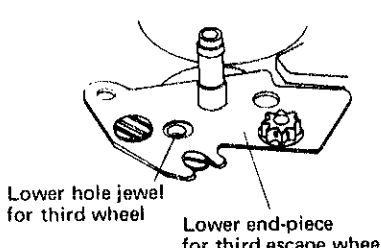
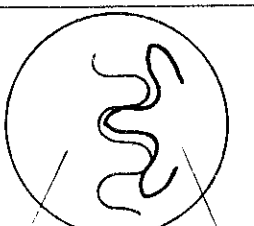
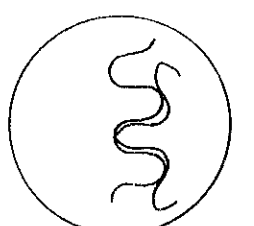
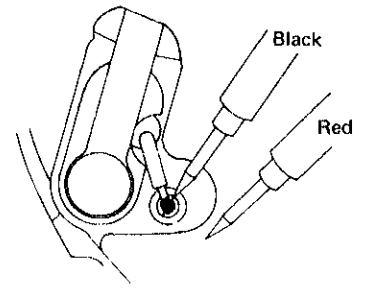
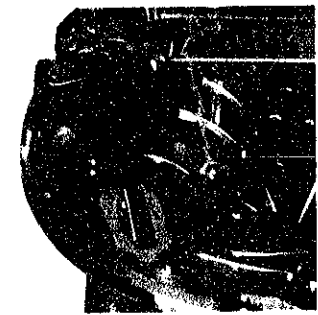
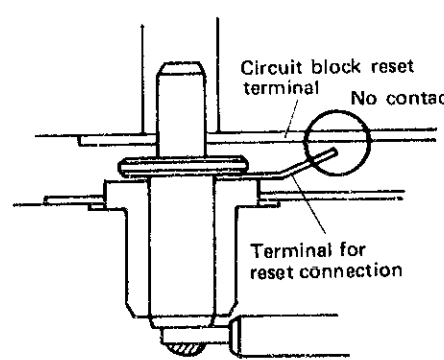

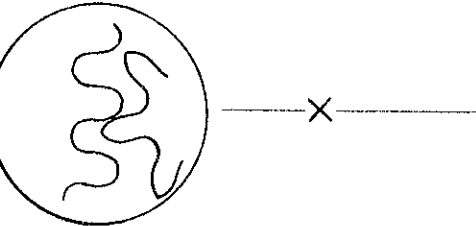
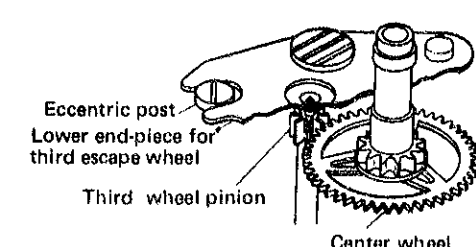
L

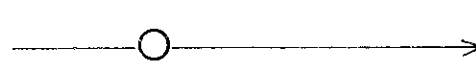

○ ———→

× ———→

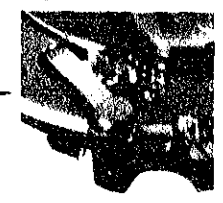
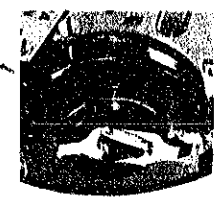
- Replace second jumper

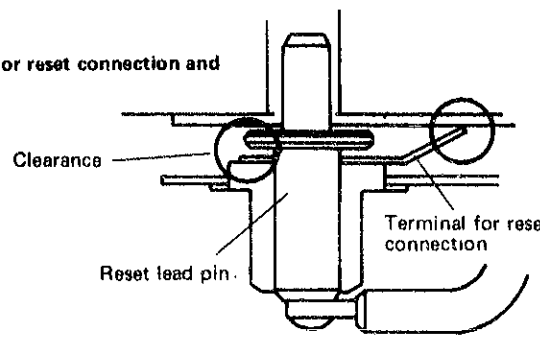

	Procedures	
CHECKING LOWER END-PIECE FOR THIRD ESCAPE WHEEL	<p>Check meshing condition of center wheel and third wheel pinion (use microscope).</p> <ol style="list-style-type: none"> 1. Remove dial, day star with dial disk, date dial, and hour wheel guard. 2. Assemble only third wheel and pinion and third wheel bridge. 3. Check meshing condition of center wheel and third wheel pinion through third wheel jewel portion of lower end-piece for third escape wheel. <p>Check entire circumference of center wheel.</p> 	 <p>Center wheel Third wheel pinion</p> 
CHECKING RESET CONDITION	<p>Check if reset condition is correct.</p> <ul style="list-style-type: none"> • Perform checking operation with a circuit block assembled <ol style="list-style-type: none"> 1. Check if second hand moves correctly after just one second when pushing in crown from second step to normal position. 2. Check conductivity of reset lead pin and plate at crown second step. <ul style="list-style-type: none"> • Set tester <ul style="list-style-type: none"> Range at OHMS x 1 • Measuring <ul style="list-style-type: none"> Red probe (+) plate Black probe (-) Reset probe  3. Check contact of terminal for reset connection and circuit block reset terminal. Observe through battery grooved portion.   	<p>Second hand moves after just one second</p> <p>Second hand moves irregularly</p> <p>Less than 10 Ω</p> <p>More than 10 Ω</p> <p>In contact</p> <p>No contact</p>

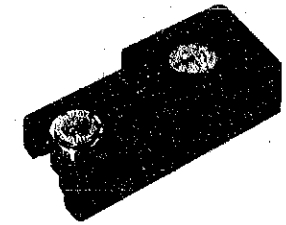
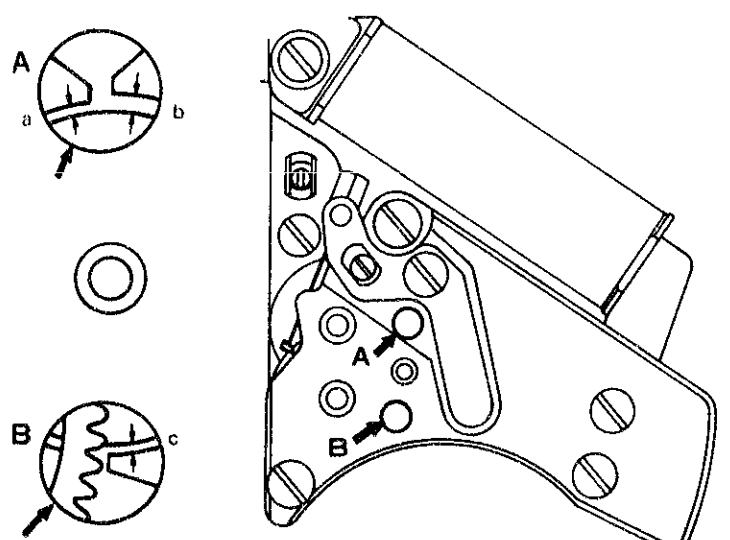
Results	Adjustment and Repair
 	 <ul style="list-style-type: none"> • Adjust lower end-piece for third escape wheel. <p><Adjusting method> After loosening lower end-piece for third escape wheel screw, adjust by turning eccentric post. When adjusting, first deeply mesh them, then adjust them in shallow-mesh position.</p>
     	<ul style="list-style-type: none"> • Defective condition causes following: <ol style="list-style-type: none"> 1) Defective contact between reset contact pin and setting wheel lever. 2) Detached reset contact pin and reset lead wire. 3) Detached reset lead wire and reset lead pin. 4) Broken reset lead wire. • Remove circuit block and bend terminal for reset connection to ensure contact with circuit block reset terminal.     

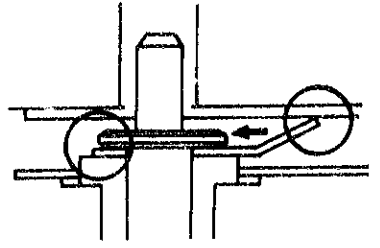
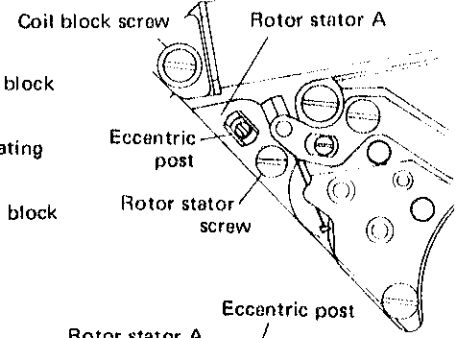
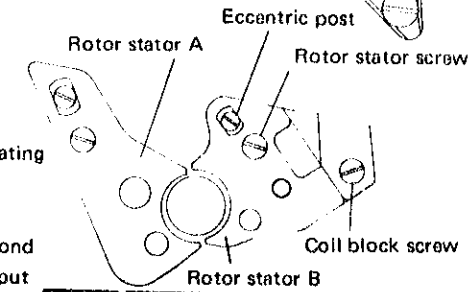
	Procedures	
CHECKING RESET CONDITION	<p>4. Detach circuit block and check for possible contamination on contacting portion of terminal for reset connection and circuit block reset terminal.</p> <p>5. Confirm contact of terminal for reset connection and reset lead pin.</p> 	<p>Uncontaminated _____</p> <p>Contaminated _____</p> <p>No clearance _____</p> <p>Clearance _____</p>
CHECKING TWO-SECOND LEAPING AND OUTPUT TORQUE	<p>1. Checking two-second leaping</p> <ul style="list-style-type: none"> ● Set Micro-test (Refer to Micro-test Handling Method) ● Clip (red) Crown ● Probe (black) ... Battery connection <p>Check motion of second hand over one minute by your eyes.</p>  <p>2. Checking output torque</p> <ul style="list-style-type: none"> ● Set movement on torque measuring apparatus (Refer to Torque Measuring Method) ● Measure output torque of center wheel and pinion (Minute hand) 	<p>The second hand moves correctly once every second _____</p> <p>The second hand leaps two seconds at a time _____</p> <p>Normal condition _____</p> <p>Defective condition _____</p>
CHECKING ROTOR STATOR	<p>Clearances between rotor stator and step rotor</p> <ul style="list-style-type: none"> ● Check clearances (a), (b), and (c) between rotor stator and step rotor by using a microscope. 	<p>When (a) is defective _____</p> <p>When (b) and (c) are defective _____</p>

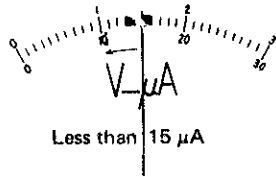
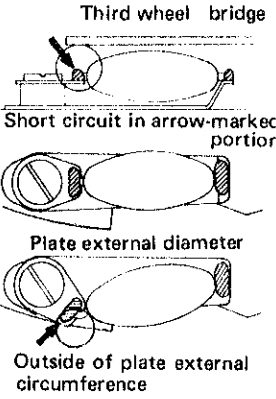
Results	Adjustment and Repair
○	<p>J 5.</p> <ul style="list-style-type: none"> ● Wipe off contamination. ● Replace circuit block (3823A) ● Replace circuit unit (3803A) ● Restore reset lead pin so it contacts terminal for reset condition  <p>Note: After pushing in the reset lead pin, check the contacting condition of terminal for reset connection and circuit block reset terminal.</p>
×	
○	
×	
○	<p>K 2.</p> <p>H</p> <p>M</p>
×	
○	<ul style="list-style-type: none"> ● Adjust rotor stator A <ol style="list-style-type: none"> 1) Loosen rotor stator screw and coil block screw. 2) Adjust rotor stator position by rotating eccentric post. 3) Tighten rotor stator screw and coil block screw.  <ul style="list-style-type: none"> ● Adjust rotor stator B <ol style="list-style-type: none"> 1) Remove third wheel bridge 2) Loosen rotor stator screw and coil block screw. 3) Adjust rotor stator position by rotating eccentric post 4) Tighten rotor stator screw. <p>After adjusting rotor stator, check second jumper, two-second leaping and output torque.</p> <p>H K</p> 
×	

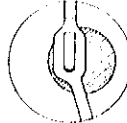
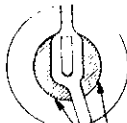
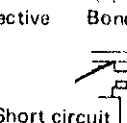
	Procedures	
M CHECKING CURRENT CONSUMPTION	<p>Use Micro-test to check if current consumption is normal, following these procedures:</p> <ol style="list-style-type: none"> 1. Set Micro-test (Refer to Micro-test Handling Method) 2. Measuring <ul style="list-style-type: none"> ● Measure current consumption with crown pushed in Clip (red) Crown Probe (black) ... Battery connection 	 <p>Less than 15 μA</p>
N CHECKING SHORT CIRCUIT IN CONDENSER OF BATTERY PROTECTION	<ol style="list-style-type: none"> 1. Check on short circuiting against third wheel bridge. 2. Check if a Minus (-) terminal of condenser of battery protection is placed at plate external circumference 3. Check on short circuit of condenser of battery protection. <ol style="list-style-type: none"> 1) Remove condenser of battery protection 2) Set tester Range at OHMS R x 1000 3) Checking Probe (red) Condenser minus (-) terminal Probe (black) Condenser plus (+) terminal <p style="text-align: center;">Check with protective condenser insulation bushing inserted</p>	 <p>Third wheel bridge</p> <p>Short circuit in arrow-marked portion</p> <p>Plate external diameter</p> <p>Outside of plate external circumference</p> <p>200 KΩ - ∞</p> <p>0 - 200 KΩ</p>
O CHECKING SHORT CIRCUIT IN BATTERY CONNECTION	<p>Check for short circuit between battery connection and plate</p> <ol style="list-style-type: none"> 1. Remove circuit block. 2. Set tester Range at OHMS R x 1000 3. Checking Probe (red) Battery connection Probe (black) Plate <p style="text-align: center;">Insulator for power connection cell</p>	<p>200 KΩ - ∞</p> <p>0 - 200 KΩ</p>

Results	Adjustment and Repair
Less than 15 μ A \bigcirc →	P
More than 15 μ A \times →	N
(Note) Read meter (center of the pointer oscillation)	
\bigcirc →	N 2.
Short circuit in arrow-marked portion \times →	● Correct shape
\bigcirc →	N 3.
\times →	● Replace battery protective condenser
\bigcirc →	O
\times →	● Replace condenser of battery connection
\bigcirc →	F
\times →	<p>Abnormal operation can be attributed to the following:</p> <ol style="list-style-type: none"> 1) Wrong placement of insulator for battery connection as shown in A.  Correct position and bond to plate.  2) Short circuit between tube of battery protective condenser and setting wheel lever. Correct by pushing in tube of battery protective condenser.  3) Short circuit between battery connection and plate caused by dust. Remove dust. 

U

CHECKING
ACCURACY

Q

TIME ACCURACY ADJUSTING METHOD—Cal. 3803A & 3823A—

Procedures

- Check gain and loss of time accuracy
1. Set Quartz Tester
(Refer to Quartz Tester Handling Method)
 2. Place watch on microphone and measure daily rates

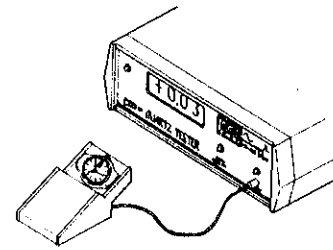

Normal _____
Defective _____

—Cal. 3803A—

Adjusting time accuracy is made by replacing condenser of oscillator regulation

There are 13 types of regulator condensers, each of different capacity.
Select suitable condenser and connect to two terminals of circuit unit.

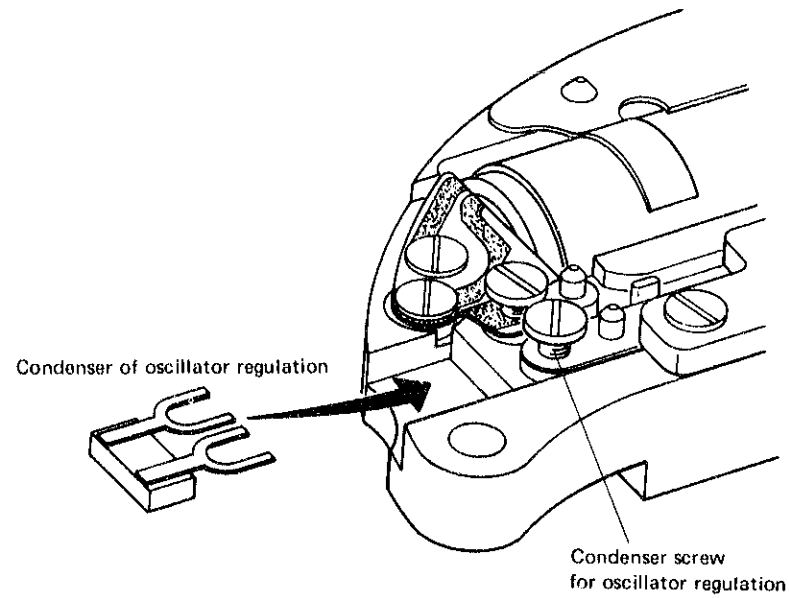

• **13 types of condensers of oscillator regulation**

Each condenser has a number indicated on the back side.

These are: 0 . 1 . 2 . 3 . 4 . 5 . 6 . 7 . 8 . 9 . X . Y . Z



• **Numbers of Condensers (Capacity) and Time Accuracy**

When small numbered condensers (smaller capacity) are used, watch movement will be gain.
When large numbered condensers (large capacity) are used, watch movement will lose.

Results

Adjustment and Repair

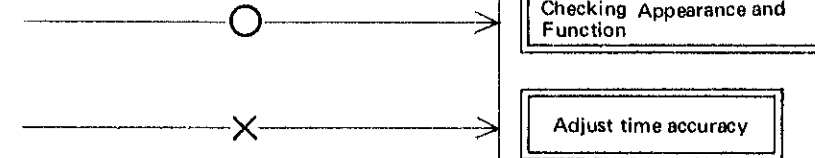

• **How to replace condensers of oscillator regulation**

1. Loosen screws and remove condenser of oscillator regulation. Confirm the number on the back side of condenser.



2. Select appropriate condenser based on following; each number represents an adjusting rate of approximately 0.4 seconds plus/minus per 24 hours.

3. Replace new condenser and tighten screws.

Notice: Be careful not to short circuit between condenser connecting terminals.

4. Check accuracy using quartz tester.

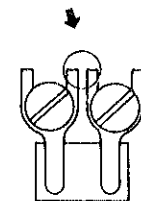

—Cal. 3823A—

Adjusting time accuracy is easily achieved by varying capacity of step variable condenser. The step variable condenser has nine condensers, each having different capacities. By combining seven condensers among these condensers, capacity can be, optionally, increased or decreased. A change of capacity is achieved by changing numbers and positions of contact spring pins.

- Capacity ratio of step variable condenser
The following diagram indicates capacity ratio of variable step condenser.
Time adjustment is precisely achieved by combining each capacity ratio.

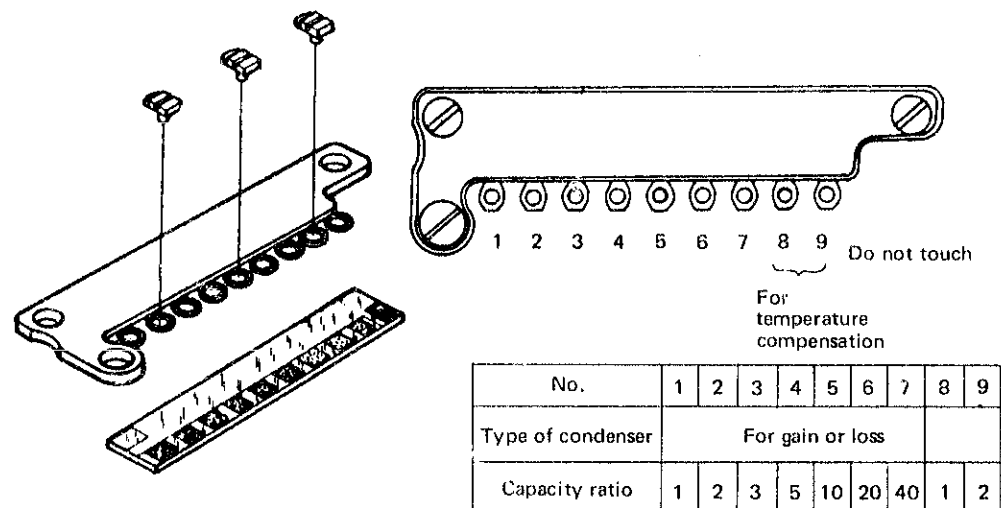

- Capacities of step variable condensers and time accuracy
Increasing capacity of step variable condensers → watch loses.
Decreasing capacity of step variable condensers → watch gains.

Contact spring pins (screws) and capacity of step variable condensers

Among seven elements of condensers, only function (those) condensers fixed with contact spring pins. The capacity of step variable condensers is the total of capacities of elements of condensers fixed with the contact spring pins. Therefore, the capacity of step variable condensers varies in conformity with the number and position of the contact spring pins.

- Setting contact spring pin
Refer to following diagram when attaching or detaching contact spring pin.

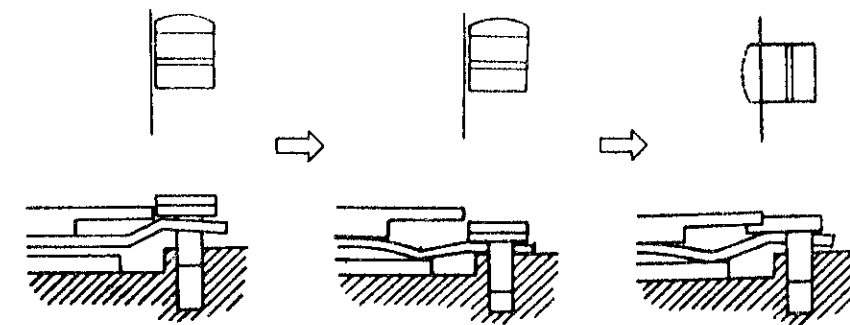

(Precautions)

1. When attaching or detaching contact spring pin, do not press it excessively. If it is pressed excessively, a contact spring of variable condenser may be deformed.
2. Do not scrape circuit block guard with contact spring pin.
3. Do not touch contact spring pins (No. 8 and 9.)
4. Use one or more contact spring pins among Nos. 5, 6, and 7. should watch lose excessively, replace circuit block.

(Example) When pins are positioned as in following diagram.

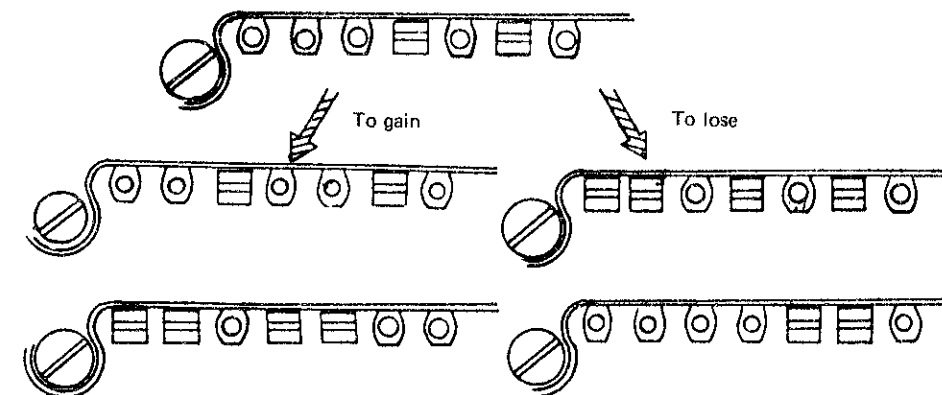

TESTING WATCH ACCURACY

The 3803A is so designed that it maintains high accuracy at the temperature when worn on the wrist. Therefore, when testing with the quartz tester, if there is a difference between the temperature of the room and that of a watch worn on the wrist, there will be a slight difference between the reading of the tester and the actual value.

For example, when the room temperature is 25°C the quartz tester will show a plus (fast) reading, because the temperature of the watch when worn on the wrist is 30°C.

The accuracy of the 3803A is within plus/Minus 10 seconds per month, or calculated on a daily basis this is within plus/minus 0.3 seconds. Therefore, even when the tester indicates a reading exceeding plus 0.5 seconds, because of the foregoing explanation, the timing will actually be slower than indicated by the tester when worn on the wrist. Thus, the average daily tolerance will be within plus/minus 0.3 seconds per day.

Quartz crystal watches displayed in illuminated show cases will have a high temperature. When tested with the quartz tester, test values will, therefore, show a variance. Test values for watches in such condition should be read after the temperature of watches has become stabilized. This also applies in case of testing watches immediately after they have removed from the wrist.

