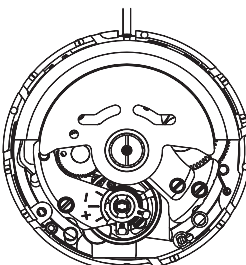
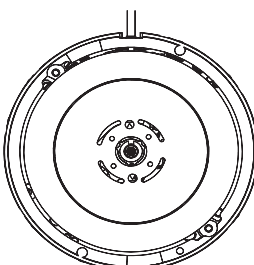

PARTS LIST/TECHNICAL GUIDE

Automatic Cal. 4R35B/4R36A

[SPECIFICATIONS]

Item	Cal. No.	4R35B/4R36A				
 <ul style="list-style-type: none"> • 3 hands (hour, minute and second hands) • Day and Date indication 		<p>The figures below are Cal. 4R36A.</p>  				
		Movement size <ul style="list-style-type: none"> • Diameter <ul style="list-style-type: none"> Outside: Ø 27.4 mm Casing: Ø 27.0 mm • Height: 5.32 mm 				
		4R35B	4R36A			
Movement size	Outside diameter	Ø 27.4 mm	Ø 27.4 mm			
	Casing diameter	Ø 27.0 mm	Ø 27.0 mm			
	Height	5.32 mm	5.32 mm			
Driving system		Automatic winding with manual winding mechanism				
Time indication		<ul style="list-style-type: none"> • 3 hands (Hour, Minute, and Small second hands) • Date indication 	<ul style="list-style-type: none"> • 3 hands (Hour, Minute, and Small second hands) • Day and date indication 			
Additional function		<ul style="list-style-type: none"> • Date correction function • Second hand stop function 	<ul style="list-style-type: none"> • Date correction function • Day correction function • Second hand stop function 			
Crown operation	Normal position	Manual winding (clockwise only)	Manual winding (clockwise only)			
	1st click position	Date setting (counterclockwise)	Date setting (counterclockwise), Day setting			
	2nd click position	Time setting (Hour and minute), Second hand stop				
Vibration per hour		21,600 (6 beats per second)				
Loss/Gain	Daily rate worn on the wrist at temperature range between 5 °C and 35 °C)	Between +45 and -35 seconds				
	Standard rate for measurement	Mainspring wind up status	Fully wind up			After 24 hours from fully wind up
		Testing positions	Dial upward: T0 (CH)	6 o'clock at the top	9 o'clock at the top	Dial upward: T24 (CH)
		Measurement (daily rate in seconds: s/d)	± 20 s/d	± 30 s/d	± 30 s/d	(Isochronism fault: T24-T0) ± 30 s/d
Regulation system		ETACHRON System				
Lift angle of the escapement		53 °				
Power reserve		From fully wound to stoppage: Approximately 40 hours				
Number of jewels		24 jewels				

SEIKO WATCH CORPORATION

PARTS LIST

Cal. 4R35B/4R36A

FEATURES

SEIKO Automatic Mechanical Cal.4R35B is replacement caliber of Cal.4R35A.

Construction of B series are same as A series, but using new parts.

Since the size of the movement is same as A series, the complete movement can be assembled into the watches which originally have the A series movement; however, as the parts are not convertible, please use the appropriate parts for each caliber.

The difference between Cal.4R35 and Cal.4R36 is a calendar mechanism.

REMARKS: Parts differences between 4R35A series and B series

	Parts name	Cal. 4R35A	Cal. 4R35B
5	DATE DISK GUARD	0808 060	0808 183
4	DATE DISK GUARD SCREW	0016 705	0012 354
7	DATE JUMPER	0810 030	0810 183
9	GUARD SCREW FOR DAY-DATE CORRECTOR SETTING TRANSMISSION WHEEL	0012 354	0012 485
10	GUARD SCREW FOR DAY-DATE CORRECTOR SETTING TRANSMISSION WHEEL	0836 010	0836 183
12	INTERMEDIATE WHEEL FOR DATE SETTING C	0962 024	0962 185
14	DATE SETTING WHEEL	0737 300	0737 183
15	HOUR WHEEL	0271 483	0273 182
16	MINUTE WHEEL	0231 006	0261 183
18	DATE INDICATOR DRIVING WHEEL	0802 300	0802 183
23	AUTOMATIC TRAIN BRIDGE	0191 032	0191 183
24	SECOND REDUCTION WHEEL AND PINION	0514 010	0514 183
32	BARREL AND TRAIN WHEEL BRIDGE	0114 348	0114 183
33	RATCHET SLIDING WHEEL SPRING	0363 156	0363 183
35	PAWL LEVER	0831 077	0831 183
42	BARREL COMPLETE WITH MAINSPRING	0201 267	0201 083
46	CENTER WHEEL WITH CANNON PINION	0224 086	0224 183
48	YOKE SPRING	0388 071	0388 177
49	YOKE	0384 061	0384 183
50	SETTING LEVER	0383 060	0383 183
51	BALANCE STOP LEVER	0601 010	0601 183
52	CLUTCH WHEEL	0282 040	0282 183
55	MAIN PLATE	0100 493	0104 182

CHARACTERISTICS OF A MECHANICAL WATCH

1. This mechanical watch operates using power obtained from a mainspring.
2. While loss/gain of a quartz watch is indicated by a monthly or annual rate, accuracy of a mechanical watch is normally indicated by a daily rate (loss/gain per day).
3. Normal usage accuracy of a mechanical watch varies according to conditions of use (time period that the watch is worn on the wrist, temperature environment, hand movement, and winding state of the mainspring).
4. When the watch is affected by strong magnetism, it temporarily gains or loses time. If the watch encounters a strong magnetic field, the parts of the watch may be magnetized. In this case, repairs such as removal of magnetism are required.



PARTS LIST

Cal. 4R35B/4R36A



Disassembling procedures Figs. : ① → ⑤⑥

Reassembling procedures Figs. : ⑤⑥ → ①

Lubricating: Types of oil

-  AO-3 (Moebius A)
-  SEIKO Watch Oil S-6
-  SEIKO Watch Oil S-4

Oil quantity

-  Liberal quantity
-  Normal quantity

[CALENDAR MECHANISM 1]

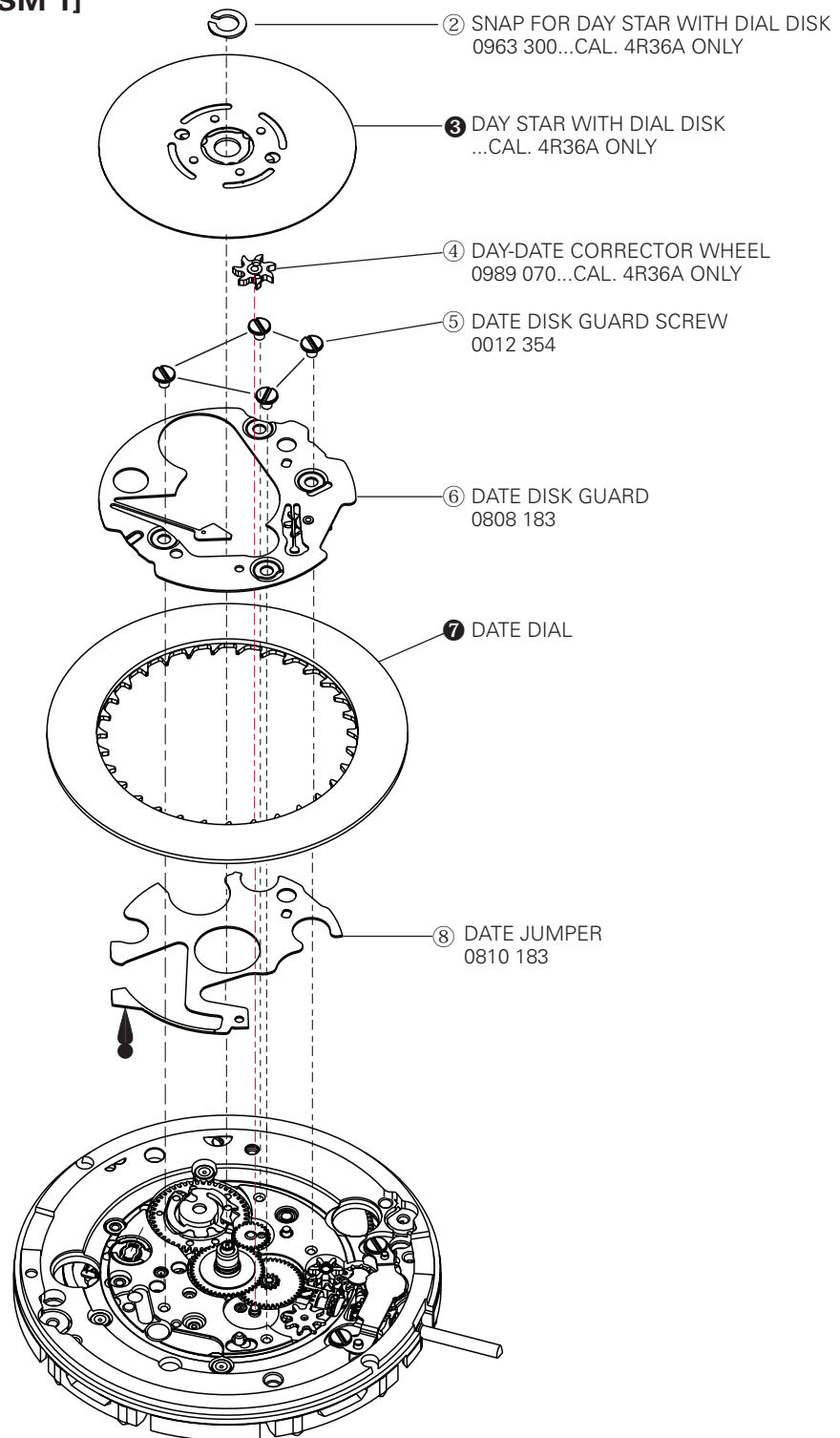



● → Please refer to the following pages.

PARTS LIST

Cal. 4R35B/4R36A

Lubricating: Types of oil

-  AO-3 (Moebius A)
-  SEIKO Watch Oil S-6
-  SEIKO Watch Oil S-4

[CALENDAR MECHANISM 2]

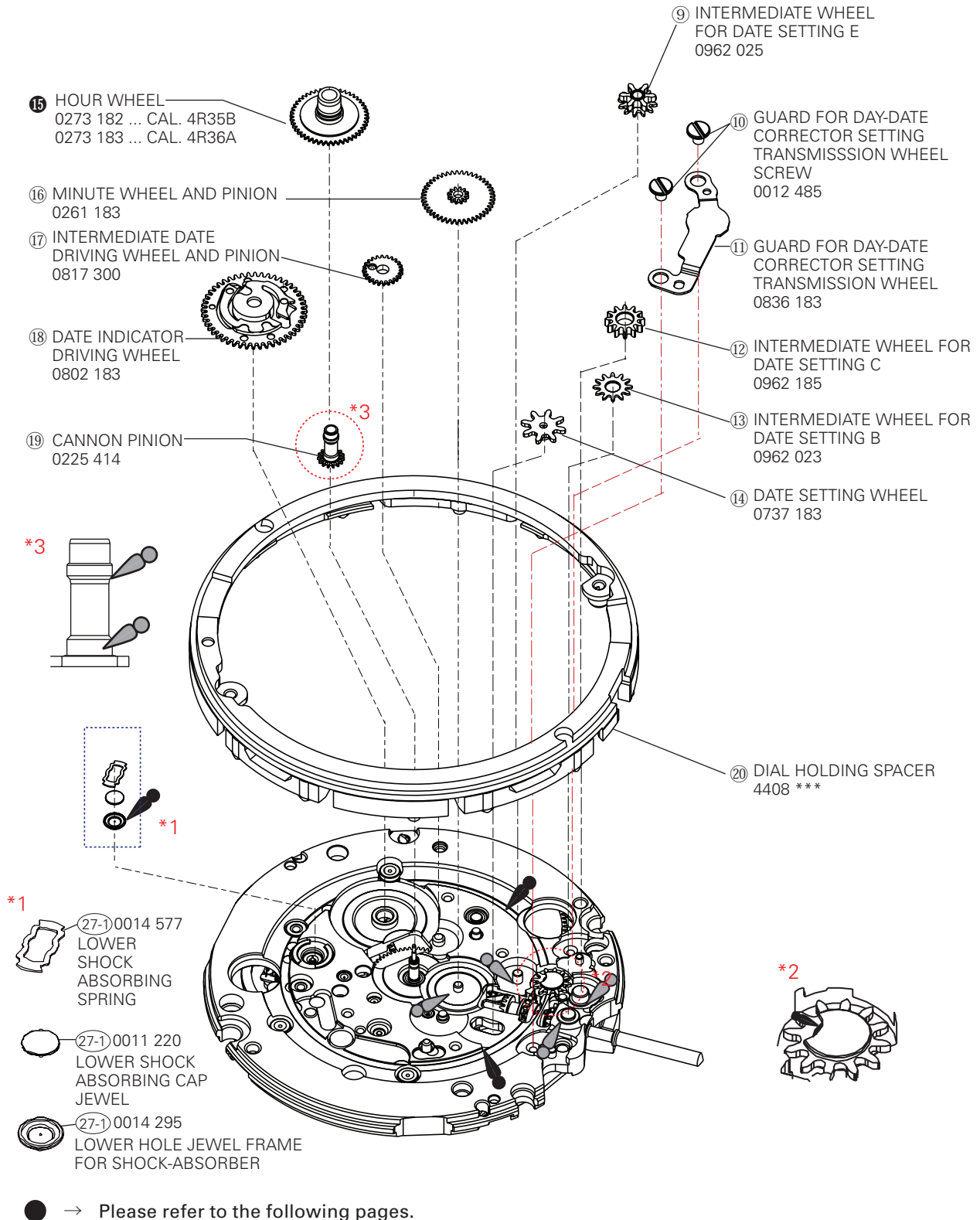



PARTS LIST

Cal. 4R35B/4R36A

[BALANCE AND ESCAPEMENT]

Lubricating: Types of oil

-  AO-3 (Moebius A)
-  SEIKO Watch Oil S-6
-  SEIKO Watch Oil S-4

① OSCILLATING WEIGHT WITH BALL BEARING
Refer to SEIKO Web Parts Catalogue.
050****

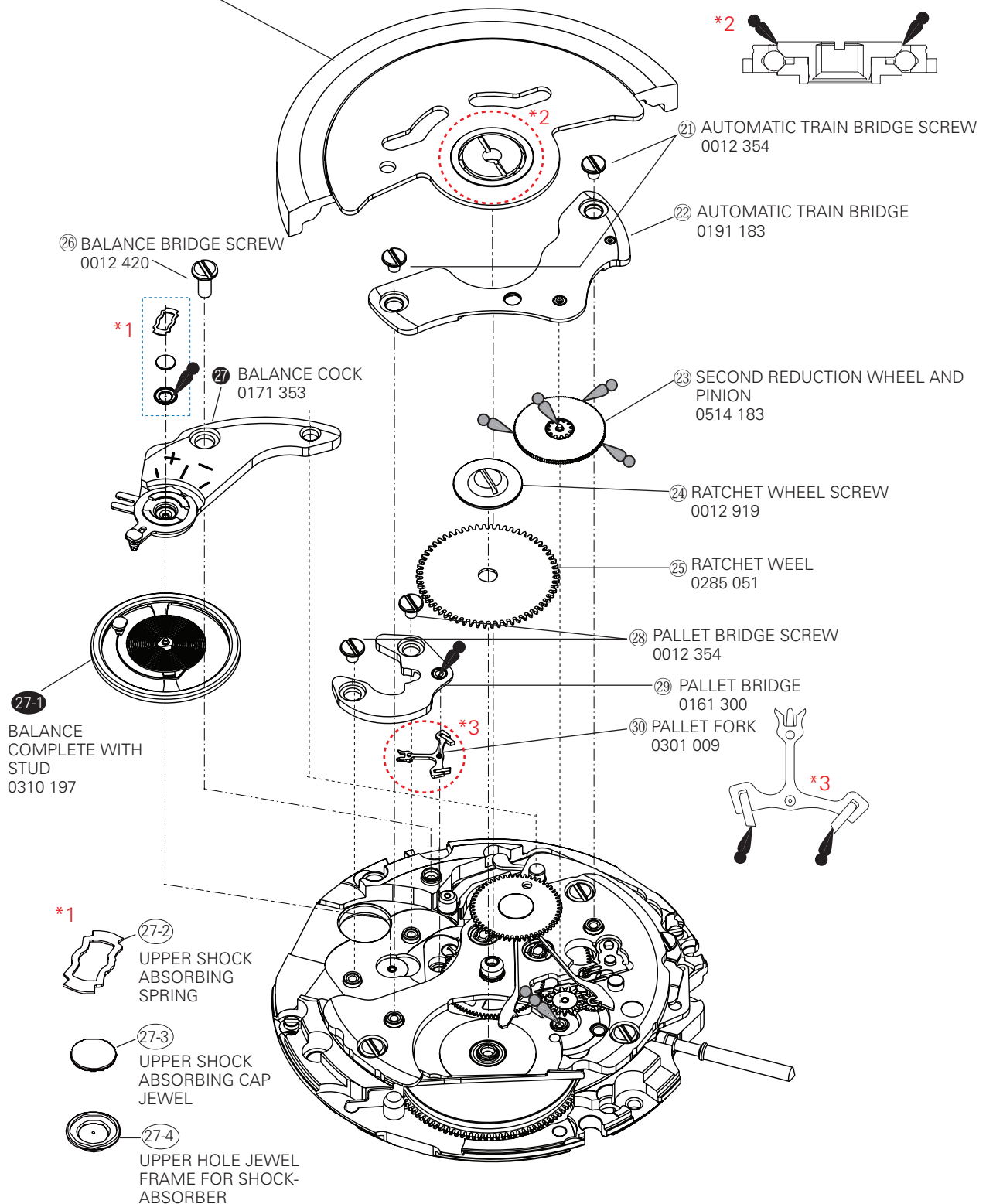



● → Please refer to the following pages.

PARTS LIST

Cal. 4R35B/4R36A

[WINDING MECHANISM]

Lubricating: Types of oil

-  AO-3 (Moebius A)
-  SEIKO Watch Oil S-6
-  SEIKO Watch Oil S-4

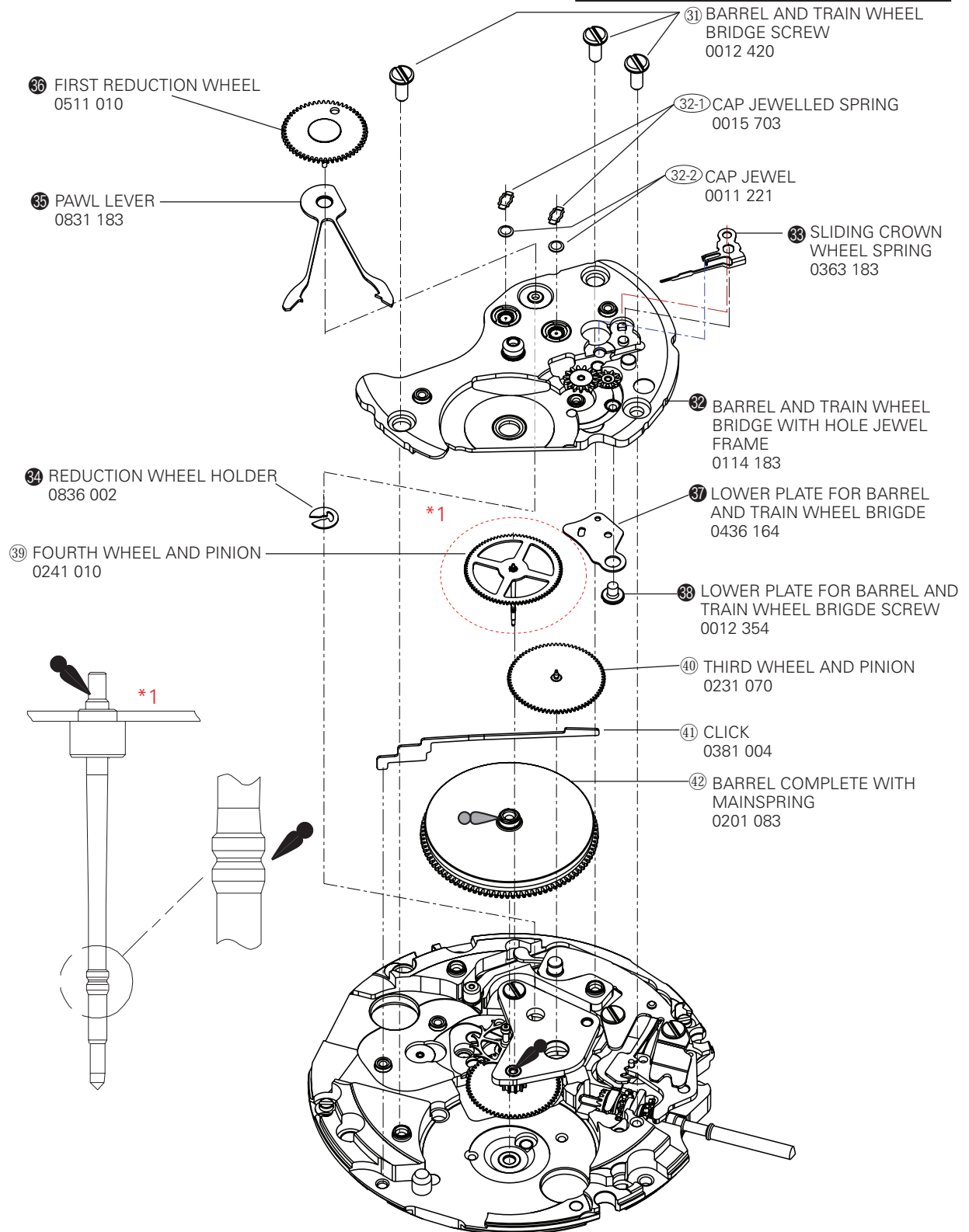



 → Please refer to the following pages.

PARTS LIST

Cal. 4R35B/4R36A

[SETTING MECHANISM]

Lubricating: Types of oil

-  AO-3 (Moebius A)
-  SEIKO Watch Oil S-6
-  SEIKO Watch Oil S-4

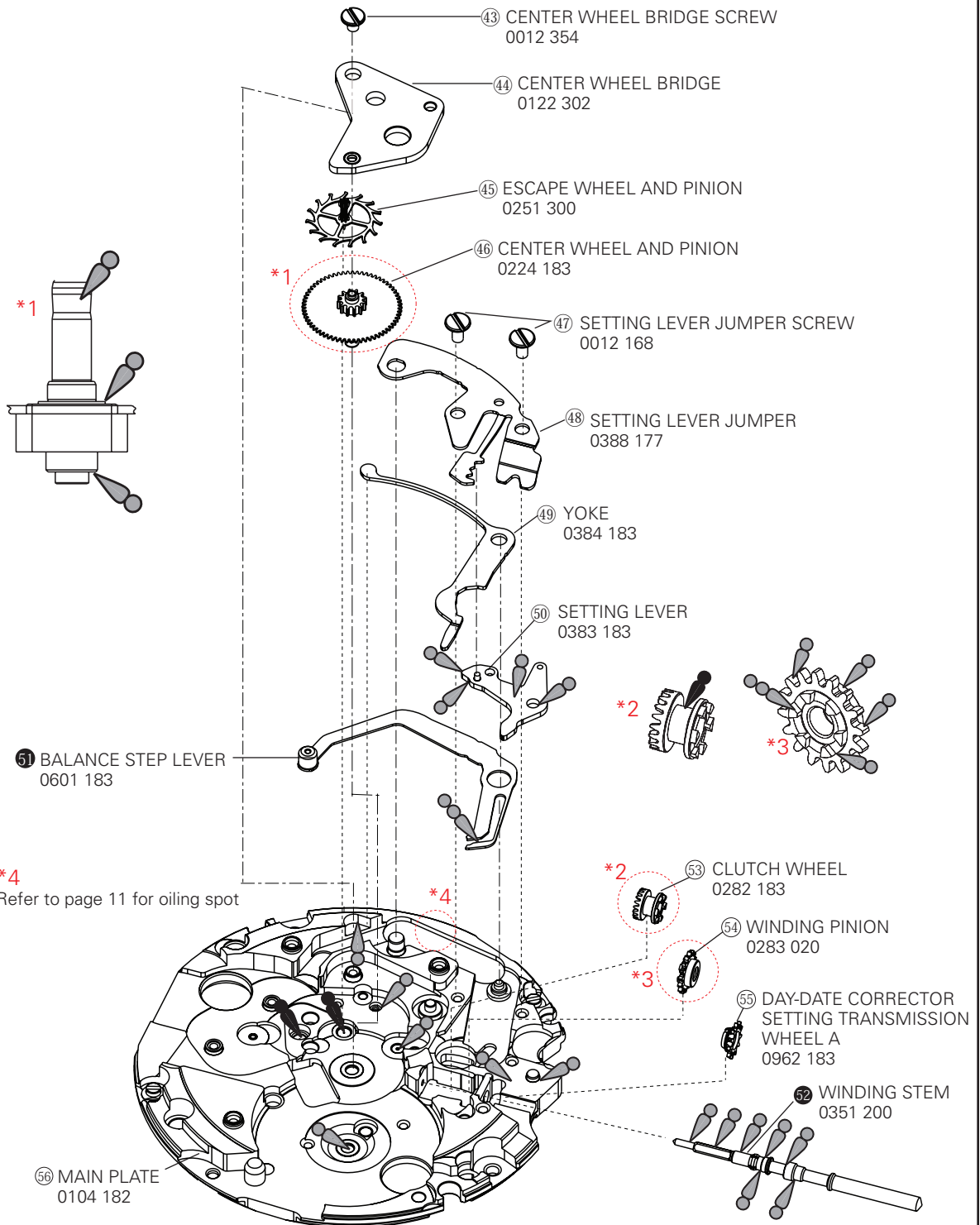

● → Please refer to the following pages.

PARTS LIST

Cal. 4R35B/4R36A

REMARKS

● How to find the correct parts, if not determined by 4 digit caliber number

Following parts are determined based on the design of watches, such as hands height, dial color, and design of cases. Please refer to the SEIKO WATCH PARTS CATALOGUE in order to choose corresponding parts.

① OSCILLATING WEIGHT 050 ***

The type of OSCILLATING WEIGHT is determined based on the design of cases. Check the case number and refer to the "SEIKO WATCH PARTS CATALOGUE" to choose corresponding OSCILLATING WEIGHT.

③ DAY STAR WITH DIAL DISK (Cal. 4R36)

Parts code	Crown position	Date position	Color of figure	Color of background
0160 242	3H	3H	MON-FRI: Black SAT : Blue SUN : Red	White

The above DAY STAR WITH DIAL DISK is used when both the crown and the day frame are located at 3 o'clock. When ordering any other type of the DAY STAR WITH DIAL DISKS, clearly mention the number printed on the disk.

⑦ DATE DIAL (CAL.4R35B/4R36A) 0878 ***

The type of DATE DIAL is determined based on the design of cases. Check the case number and refer to the "SEIKO WATCH PARTS CATALOGUE" to choose corresponding DATE DIAL.

⑳ DIAL HOLDING SPACER 4408 ***

The type of DIAL HOLDING SPACER is determined based on the design of cases. Check the case number and refer to the "SEIKO WATCH PARTS CATALOGUE" to choose corresponding DIAL HOLDING SPACER.

Note: The DIAL HOLDING SPACER is not used for the machine code 4R3620. Machine code is shown on the bottom line of the exterior parts of the Watch Parts Catalogue web site.

㉓ WINDING STEM 0351 ***

The type of WINDING STEM is determined based on the design of cases. Check the case number and refer to the "SEIKO WATCH PARTS CATALOGUE" to choose corresponding WINDING STEM.

PARTS LIST

Cal. 4R35B/4R36A

● How to discriminate resembled parts

Wheels

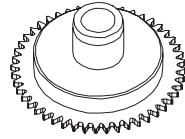
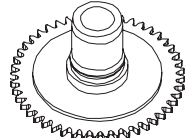
No.	Cal.	Parts code	Parts name	Parts form
⑮	4R35B	0273 182	Hour wheel	
	4R36	0273 183		

Screws

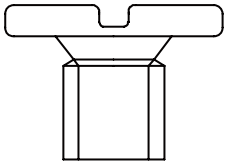
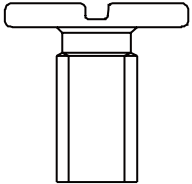
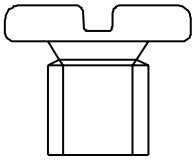
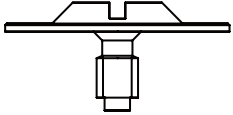
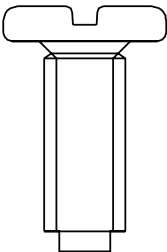
 0012354	⑤ DATE DISK GUARD SCREW (4 pcs.) ⑳ AUTOMATIC TRAIN BRIDGE (2 pcs.) ㉘ PALLET BRIDGE SCREW (2 pcs.) ㉘ LOWER PLATE FOR BARREL AND TRAIN WHEEL BRIDGE SCREW (1 pce.) ㉘ CENTER WHEEL BRIDGE SCREW (1 pce.)
 0012168	㉘ YOKE SPRING SCREW (2 pcs.)
 0012485	㉘ GUARD FOR DAY-DATE CORRECTOR SETTING TRANSMISSION WHEEL SCREW (2 pcs.)
 0012919	㉘ RATCHET WHEEL SCREW (1 pce.)
 0012420	㉘ BALANCE BRIDGE SCREW (1 pce.) ㉘ BARREL AND TRAIN WHEEL BRIDGE SCREW (3 pcs.)

REMARKS ON DISASSEMBLING AND REASSEMBLING THE MOVEMENT

● How to remove the SETTING STEM before dismantling the movement

Crown position: NORMAL

Push the A portion on the SETTING LEVER gently (refer to the picture on the right) in order to disengage it from the WINDING STEM.

Then pull out the crown with the stem completely.

- * After dismantling the movement from the case, push back the crown with the WINDING STEM to the movement.

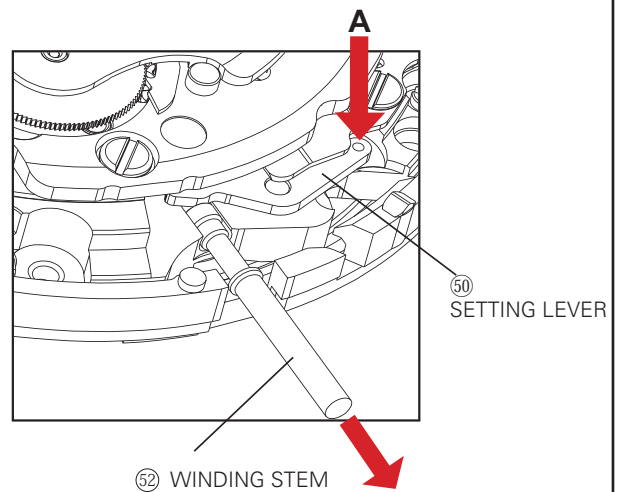

● Balance and escapement

How to disassemble/reassemble the BALANCE and BALANCE COCK

• Disassembling

- 1) Rotate the STUD SUPPORT until it touches to the BALANCE COCK.

When doing so, make sure that the second bend of the balance-spring does not touch the REGULATOR PIN.

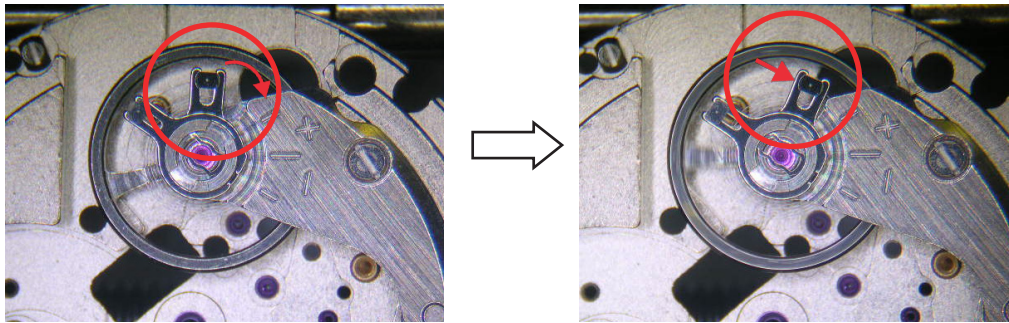

- 2) Push out the stud parallel to the slit of the STUD SUPPORT (the direction also shown by the red arrow in the illustration) in order to remove it from the STUD SUPPORT.

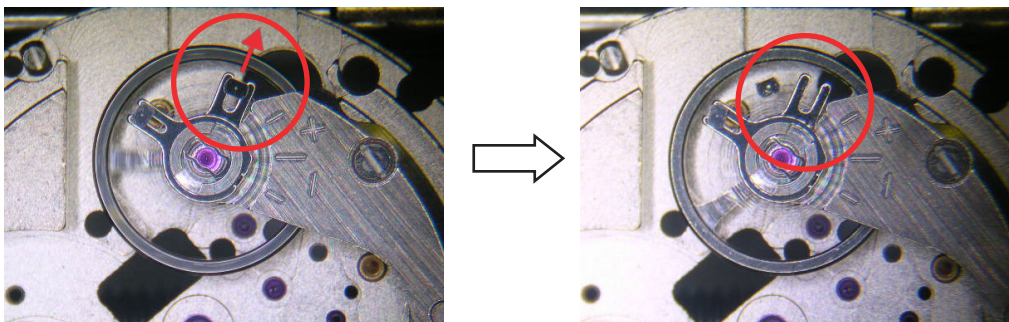

- 3) Unscrew the BALANCE COCK SCREW and remove the BALANCE COCK WITH REGULATOR.

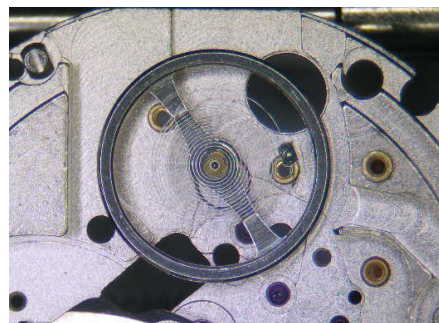

- 4) Remove the BALANCE COMPLETE WITH STUD.

- **Reassembling**

1) Install the BALANCE COMPLETE WITH STUD to the MAIN PLATE.

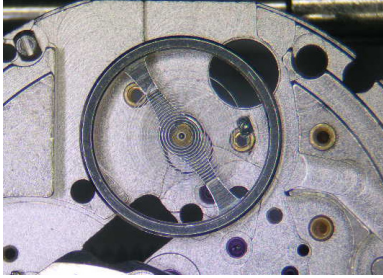

2) Set the BALANCE COCK WITH REGULATOR and tighten the BALANCE COCK SCREW.

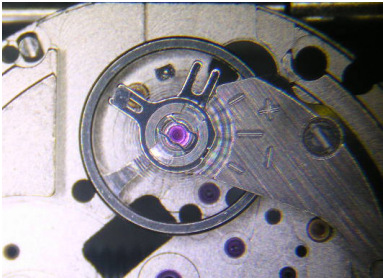

3) Temporarily set the stud to the STUD SUPPORT.

Do not engage the balance-spring to the REGULATOR PIN. The balance-spring passes outside of the REGULATOR-PIN at this stage.

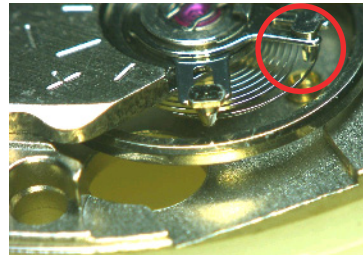
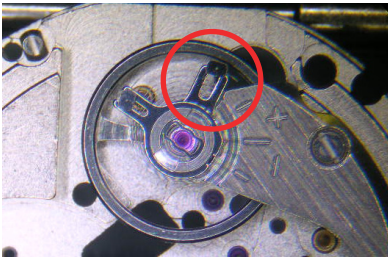

4) Push back the stud parallel to the slit of the STUD SUPPORT.

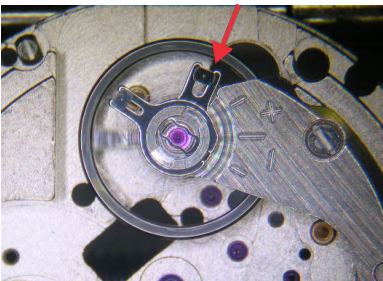

5) Engage the balance-spring with the slit of the REGULATOR PIN.

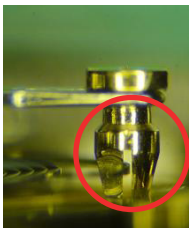

* When assembling the BALANCE COMPLETE, pay great attention not to deform the balance-spring, especially at the second bend.

● First reduction wheel holder

• Disassembling

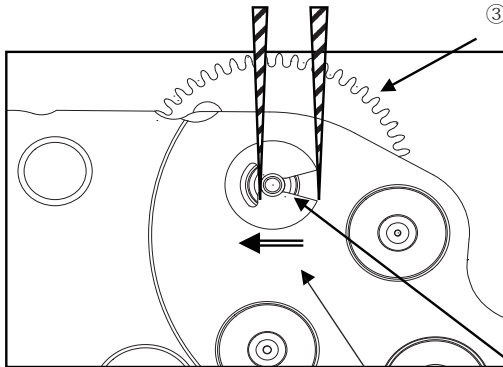

• Reassembling

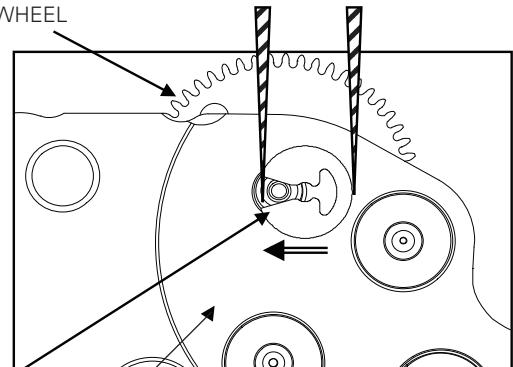

③ FIRST REDUCTION WHEEL

④ REDUCTION WHEEL HOLDER

③ BARREL AND TRAIN WHEEL BRIDGE (BACK SIDE)

● Oscillating weight

When fixing the OSCILLATING WEIGHT, an alignment with the FIRST REDUCTION WHEEL is necessary in order to wind the MAINSPRING most efficiently. Rotate the FIRST REDUCTION WHEEL manually until its hole aligns with the gilt dot on the BALANCE COCK and set the OSCILLATING WEIGHT vertically at the stem side, and then tighten the screw. Refer to the figure below.

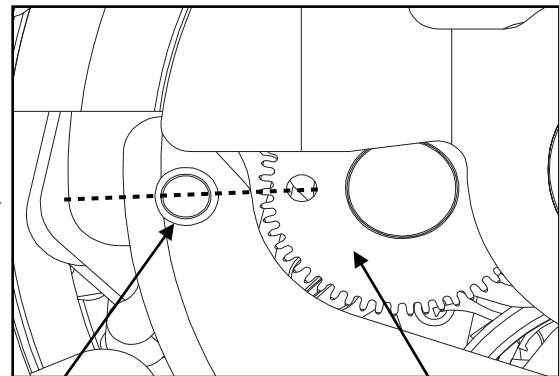
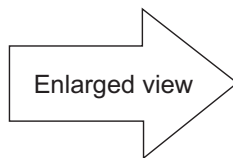
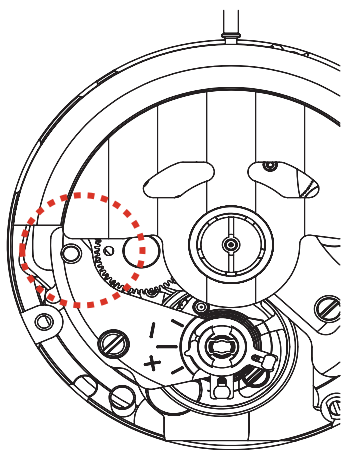



BALANCE BRIDGE GUIDE PIN

③⑥ FIRST REDUCTION WHEEL PIN

● **Barrel and train wheel bridge with hole jewel frame.**

③② BARREL AND TRAIN WHEEL BRIDGE WITH HOLE JEWEL FRAME

Lubricating: Types of oil

-  AO-3 (Moebius A)
-  SEIKO Watch Oil S-6
-  SEIKO Watch Oil S-4

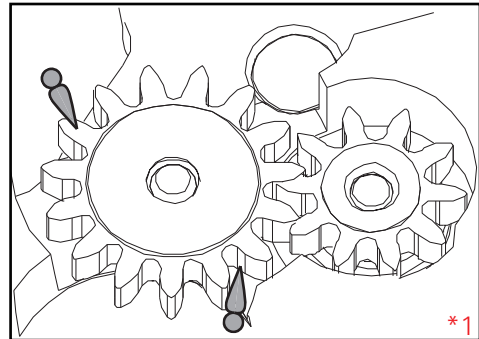
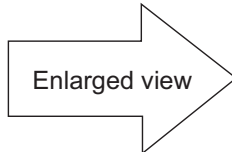
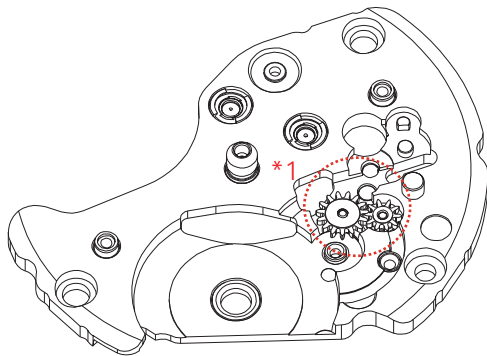

Back side

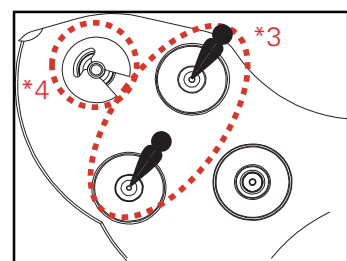
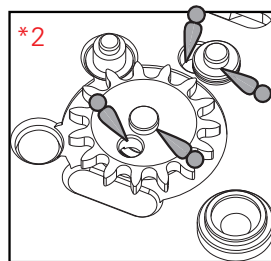
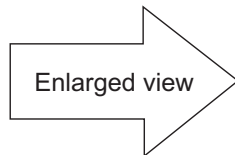
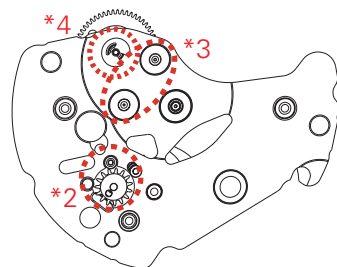

***2** After lubricating, set lower plate for barrel and train wheel bridge & screw.

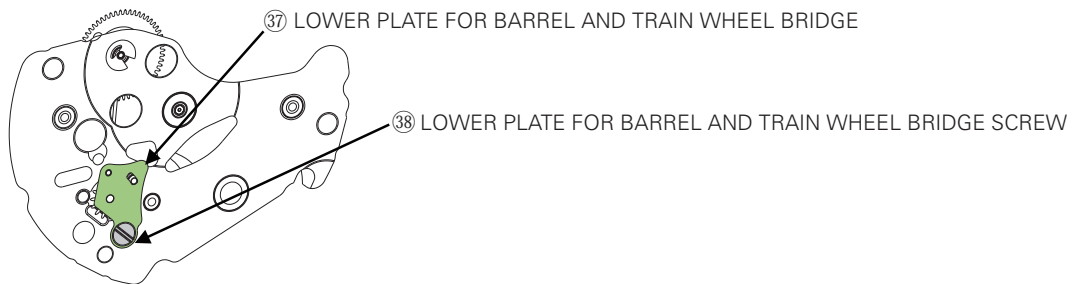

***4** After lubricating, set First reduction wheel & Pawl lever & Reduction wheel holder.

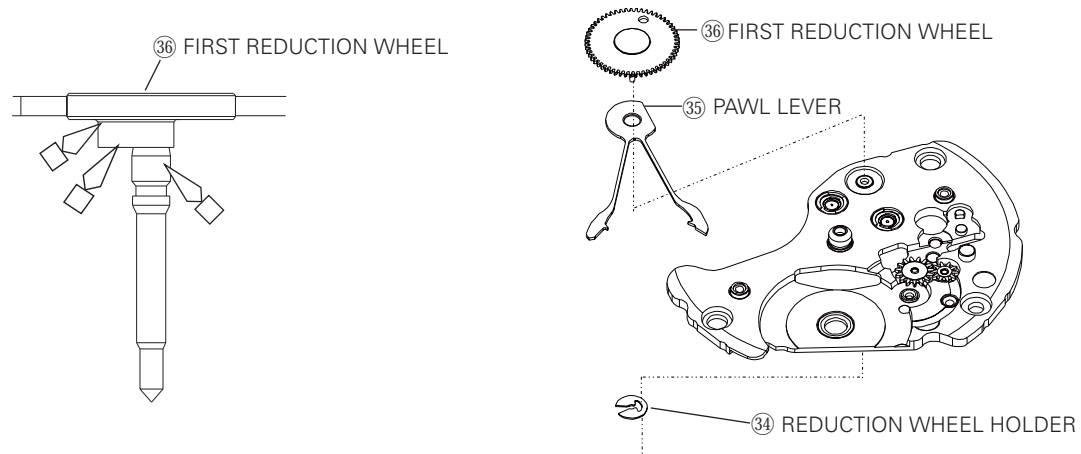

● **Balance stop lever**

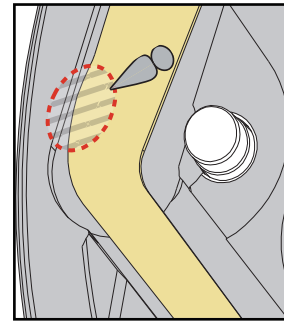
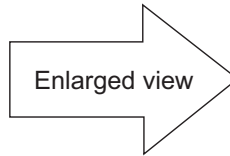
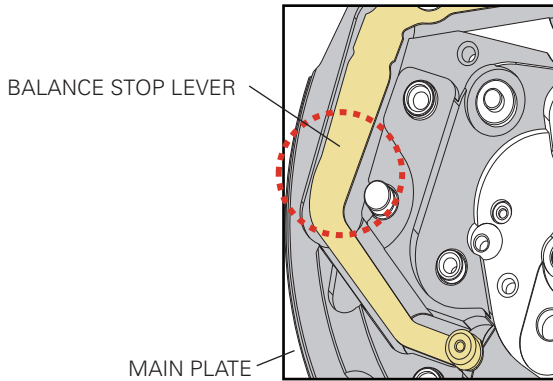

Contact part of main plate and balance stop lever

● **Sliding crown wheel spring**

• **Disassembling**

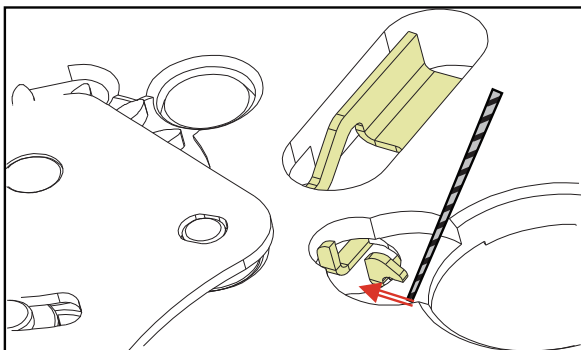
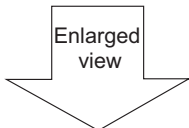
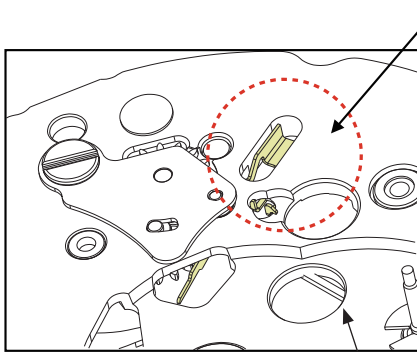

Remove the hook of the SLIDING CROWN WHEEL SPRING from BARREL AND TRAIN WHEEL BRIDGE WITH HOLE JEWEL FRAME.

• **Reassembling**

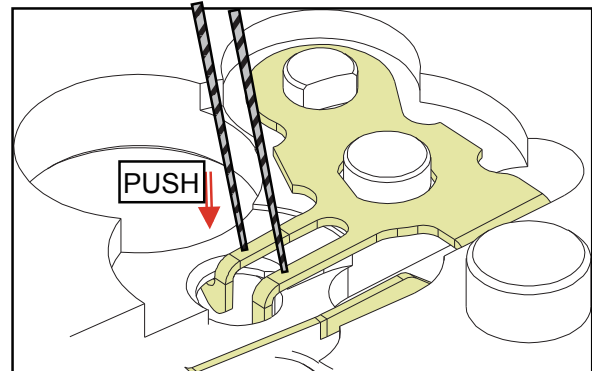
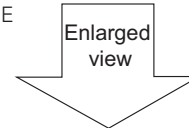
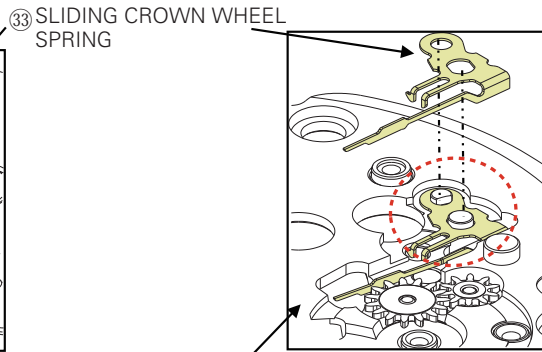

The hook of SLIDING CROWN WHEEL SPRING is hang up a BARREL AND TRAIN WHEEL BRIDGE WITH HOLE JEWEL FRAME.

REGULATION

● Names of the parts for regulation and their functions

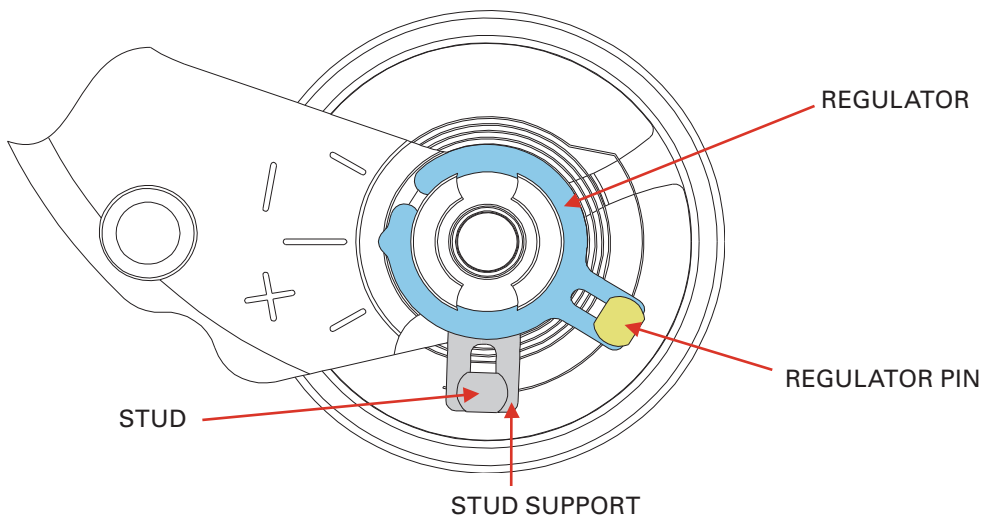

Note:

• Regulator

Regulation of the accuracy rate(+) or (-) by adjusting the operative length of the balance-spring

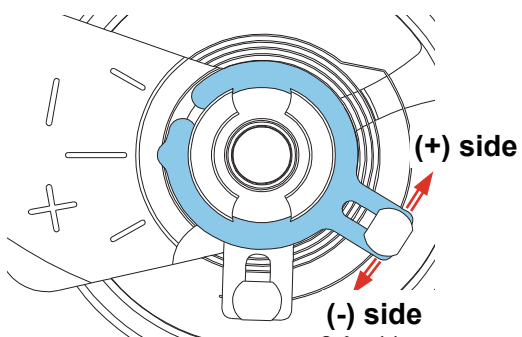

• Stud support

Correction of the beat error by positioning the roller jewel correctly

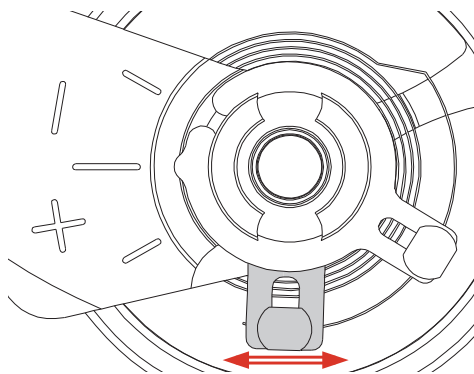

• Stud (glued at the balance-spring)

Alignment of the balance-spring to the center of the regulator pin's slit

• Regulator pin

Adjustment of the play of the balance-spring embraced in its slit

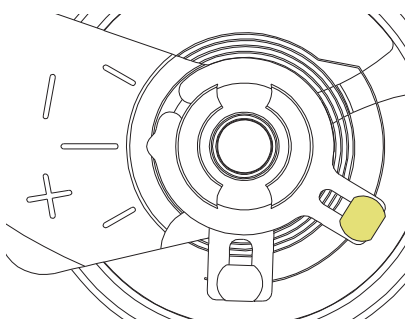

Counterclockwise rotation

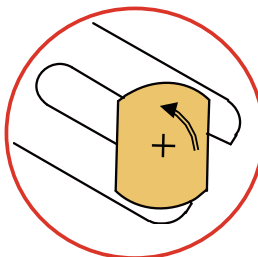

No clockwise rotation

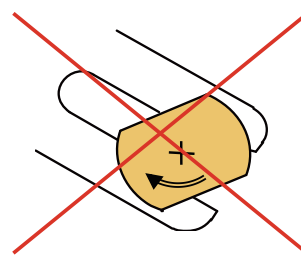

● **How to regulate the isochronism fault by adjusting the position of the balance-spring**

This caliber has the Etachron system for fine regulation of the isochronism fault.

When an amplitude of the balance becomes weak, the watch shows time loss, in general.

By making a clearance of the balance-spring smaller, the decline curve of the instantaneous rate gets shallower.

- 1) Make sure that the REGULATOR PIN is aligned in a vertical position to the REGULATOR and the balance-spring passes parallel through the slot of the REGULATOR PIN before fine-tuning the STUD and the REGULATOR PIN.

REGULATOR PIN

top side view

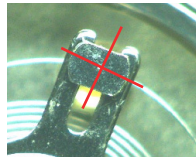

back side view

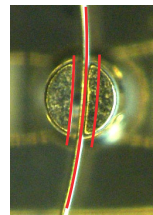

angled view



- 2) Rotate the STUD in order to align the position of the balance-spring passes through the center of the slot of the REGULATOR PIN.

STUD

top side view



REGULATOR PIN

back side view

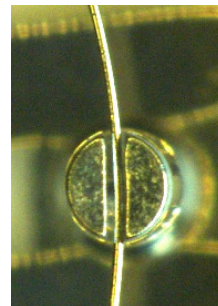

- 3) Rotate the REGULATOR PIN counterclockwise in order to fine-tune the clearance of the balance-spring passing through the slot of it.

REGULATOR PIN

top side view

Before rotating



After rotating

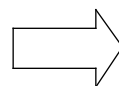

back side view

Before rotating

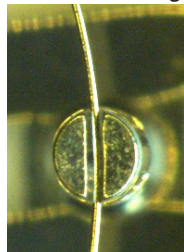

After rotating

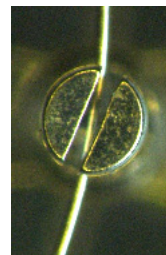

(Maximum clearance)

(Minimum clearance)

REMARKS ON INSPECTION AND MEASUREMENT

● Function check

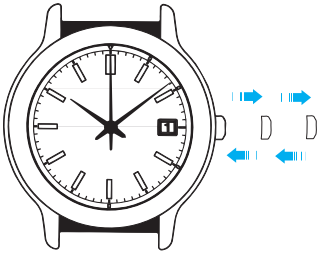
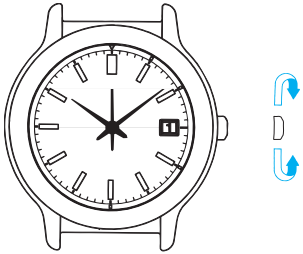
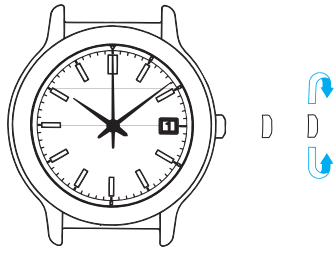
Operation	Function	Checkpoint
 <p>Pull out the crown to the 2nd click and push it back in to the normal position. Repeat the same several times.</p>	<p>Setting mechanism - switching the function of the time setting</p>	<p>Make sure that it has a click at each position and the stem is not pulled off.</p>
 <p>Pull out the crown to the 1st click, then turn it.</p>	<p>Calendar mechanism - correcting the date (and day), if available</p>	<p>Make sure that the date (and day) changes smoothly.</p>
 <p>Pull out the crown to the 2nd click, then turn it.</p>	<p>Setting mechanism - hour and minute hand setting</p> <p>Hands installation</p> <p>Calendar mechanism - date change</p>	<p>Make sure that the hour and minute hands move smoothly (without touching each other or touching the surface of the dial or inside of the glass).</p> <p>Make sure that the date changes when the hour and minute hands pass around midnight.</p>

TECHNICAL GUIDE

Cal. 4R35B/4R36A

● **Water resistance test**

Check the water resistance according to the designated specification of the watch.

Marking on the case back	Test method	Applied pressure
WATER RESISTANT (WATER RESIST)	Air leak test	3 BAR
WATER RESIST 5BAR	Water pressure test ↓	5 BAR
WATER RESIST 10BAR		10 BAR
WATER RESIST 15BAR	Condensation test	15 BAR
WATER RESIST 20BAR		20 BAR
SCUBA DIVER'S (AIR DIVER'S) 150 m	Condensation test ↓	18.75 BAR = 150 (m) times 0.125
SCUBA DIVER'S (AIR DIVER'S) 200 m		25 BAR = 200 (m) times 0.125
He-GAS DIVER'S 300 m	Water pressure test ↓	37.5 BAR = 300 (m) times 0.125
He-GAS DIVER'S 600 m		75 BAR = 600 (m) times 0.125
He-GAS DIVER'S 1000 m	Condensation test	125 BAR = 1000 (m) times 0.125

● Accuracy test

Measure the rate in three different positions within 30 minutes after the watch is fully wound up (wait approximately for 5 minutes after winding up in order to get a stable oscillation of the balance) and make sure the value shows within the range in the table below.

Measure the rate in dial-up position after 24 hours from fully wound up (T24) and check the rate difference with the rate in dial-up position when it is fully wound up (T0). Make sure that the value of T24-T0 shows within the range of the isochronism in the table below.

Standard rate for measurement	Mainspring wind up status	Fully wind up (T0)			After 24 hours from fully wind up (T24)
	Testing positions	Dial upwards: T0 (CH)	6 o'clock at the top	9 o'clock at the top	Dial upwards: T24 (CH)
	Measurement (daily rate in seconds:s/d)	±20 s/d	±30 s/d	±30 s/d	(Isochronism fault: T24-T0) ±30 s/d

ACCURACY OF MECHANICAL WATCHES

- ❖ The accuracy of mechanical watches is indicated by the daily rates of one week or so.
- ❖ The accuracy of mechanical watches may not fall within the specified range of time accuracy because of loss/gain changes due to the conditions of use, such as the length of time during which the watch is worn on the wrist, arm movement, whether the mainspring is wound up fully or not, etc.
- ❖ The key components in mechanical watches are made of metals which expand or contract depending on temperatures due to metal properties. This exerts an effect on the accuracy of the watches. Mechanical watches tend to lose time at high temperatures while they tend to gain time at low temperatures.
- ❖ In order to improve accuracy, it is important to regularly supply energy to the balance that controls the speed of the gears. The driving force of the mainspring that powers mechanical watches varies between when it is fully wound and immediately before it is unwound. As the mainspring unwinds, the force weakens.
- ❖ Relatively steady accuracy can be obtained by wearing the watch on the wrist frequently for the self-winding type and winding up the mainspring fully everyday at a fixed time to move it regularly for the wind-up mechanical type.
- ❖ When affected by external strong magnetism, a mechanical watch may loss/gain time temporarily. The parts of the watch may become magnetized depending on the extent of the effect. In such a case, consult the retailer from whom the watch was purchased since the watch requires repair, including demagnetizing.

● Duration time test

Check the Power reserve of the watch after the mainspring is fully wound up and leave it on natural condition with the dial-up position. Make sure that the watch runs **approximately 41 hours** until it stops.