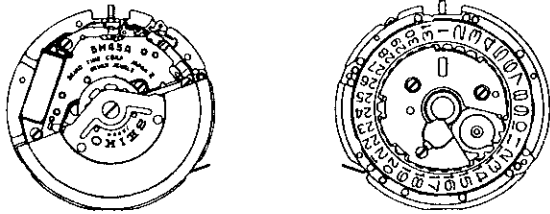

PARTS CATALOGUE/TECHNICAL GUIDE

Cal. 5M45A

[SPECIFICATIONS]

Item		Cal. No.	5M45A
Movement			 <p style="text-align: right;">(x 1.0)</p>
Movement size	Outside diameter		ø27.6 mm
	Casing diameter		ø27.0 mm
	Height		4.8 mm
Time indication			Hour, minute, second and 24-hour hands
Driving system			Step motor (Load compensated driving pulse type)
Additional mechanism			<ul style="list-style-type: none"> • Automatic generating system • Power reserve indicator • Overcharge prevention function • Electronic circuit reset switch • Train wheel setting device • Independent adjustment of hour hand • Date calendar (Date and hour hand are set simultaneously) • 24-hour hand
Loss/gain			Monthly rate at normal temperature range: less than 15 seconds
Regulation system			Nil
Measuring gate by quartz tester			Use 10-second gate.
Power supply	Power generator		Automatic generating system
	Capacitor		Polyacene lithium condenser
Operating voltage range			Capacitor voltage: 0.5 ~ 2.3 V
Duration of charge			From 1.55 V to stoppage: Approx. 168 hours
Jewels			7 jewels

PARTS CATALOGUE

Cal. 5M45A

Disassembling procedures Figs. : (1) → (54)

Reassembling procedures Figs. : (54) → (1)

Lubricating: Types of oil



● Moebius A

○ SEIKO Watch Oil S-6

Oil quantity

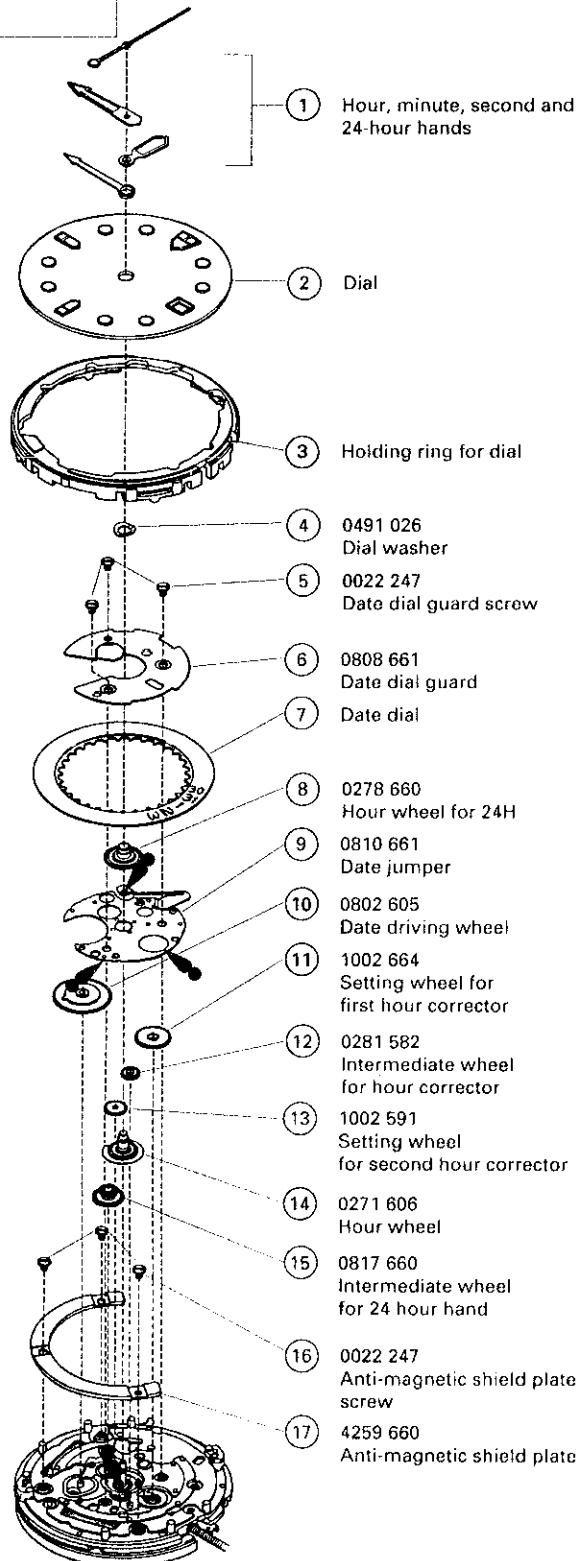
○ Normal quantity



	0022 247	
	• Date dial guard screw	(3 pcs.)
	• Anti-magnetic shield plate screw	(3 pcs.)
	• Capacitor clamp screw	(2 pcs.)
	• Circuit block cover screw	(2 pcs.)
	• Oscillating weight bridge screw	(2 pcs.)
	• Coil block screw	(1 pc.)
	• Train wheel bridge screw	(1 pc.)
	0022 490	
	• Oscillating weight screw	(1 pc.)

○ → Please see the remarks on the following pages.
(Lubricating of some parts is shown in "II. REMARKS ON DISASSEMBLING AND REASSEMBLING")

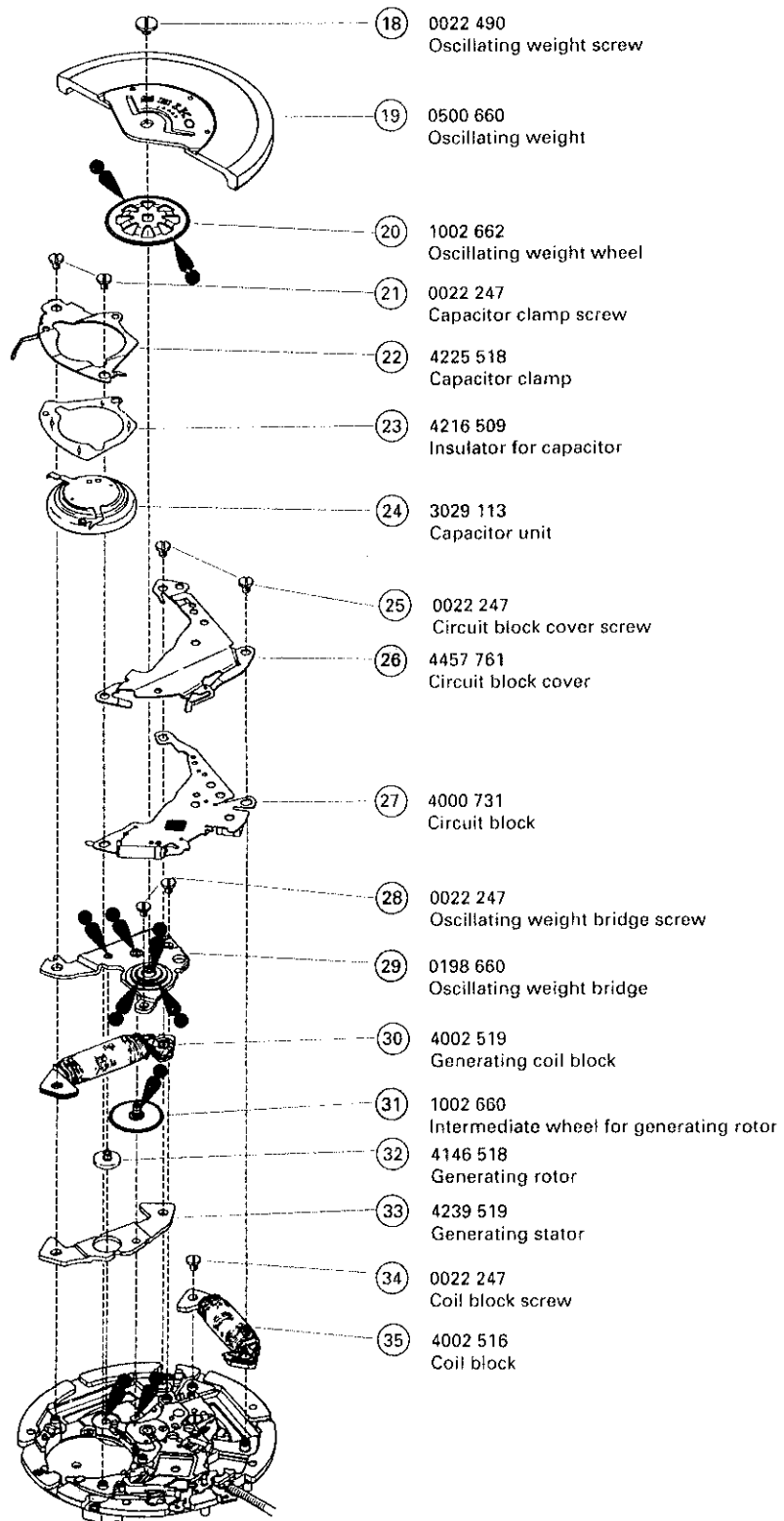

○ ⇨ Please see the remarks on the following pages.
(Lubricating of some parts is shown in "II. REMARKS ON DISASSEMBLING AND REASSEMBLING")

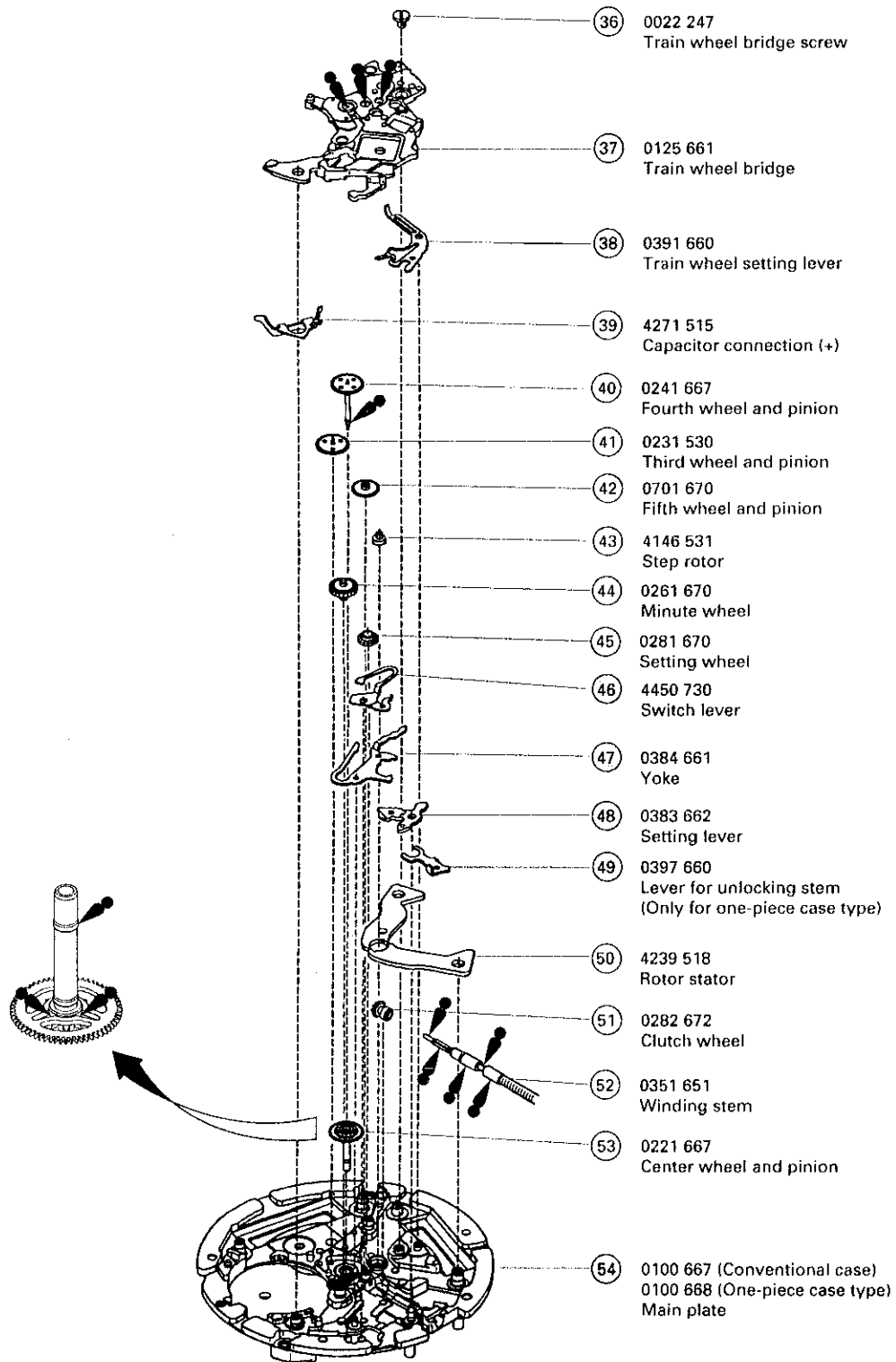

○ ➡ Please see the remarks on the following pages.
(Lubricating of some parts is shown in "II. REMARKS ON DISASSEMBLING AND REASSEMBLING")

Remarks:

③ Holding ring for dial

The type of holding ring for dial is determined based on the design of cases. Check the case number and refer to "SEIKO Casing Parts Catalogue" to choose a corresponding holding ring for dial.

⑩ Date dial

Part code	Position of crown and calendar frame	Color of figure	Color of background
0878 659	3 o'clock	Black	White

The type of date dial is determined based on the design of cases. Check the case number and refer to "SEIKO Casing Parts Catalogue" to choose a corresponding date dial.

④⑨ Lever for unlocking stem

⑤④ Main plate

Use/unuse of the lever for unlocking stem and the type of main plate are determined based on the type of cases. Refer to the table below to choose the corresponding lever for unlocking stem and main plate.

Case type	Lever for unlocking stem	Main plate
Conventional case (with case back)	Not installed	0100 667
One-piece case type	Installed	0100 668

- The explanation here is only for the particular points of Cal. 5M45A.
- For the repairing, checking and measuring procedures, refer to the "TECHNICAL GUIDE, GENERAL INSTRUCTIONS".

I. STRUCTURE OF THE CIRCUIT BLOCK

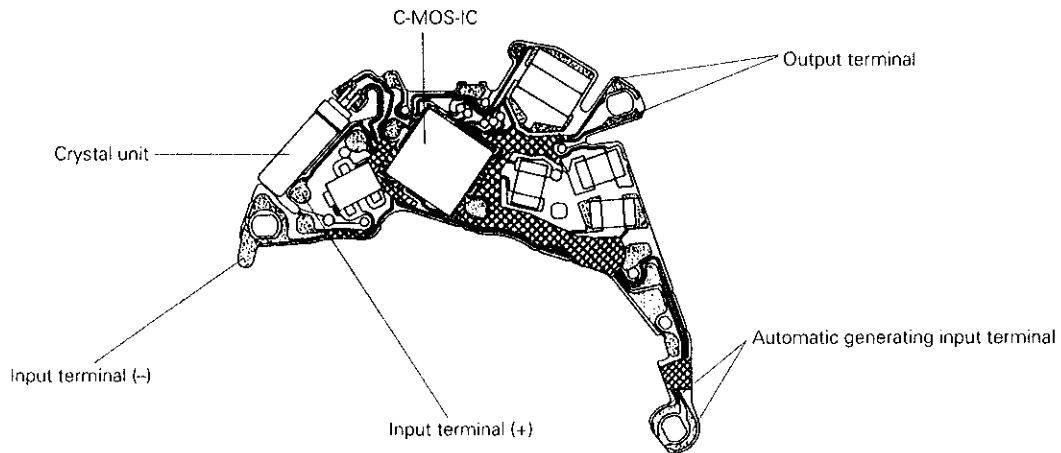

II. REMARKS ON DISASSEMBLING AND REASSEMBLING

① Hands

• How to install

Place the movement directly on the riveting plate shown in the illustration with the oscillating weight side down, so that the oscillating weight screw is not damaged. Then, press in the hands.

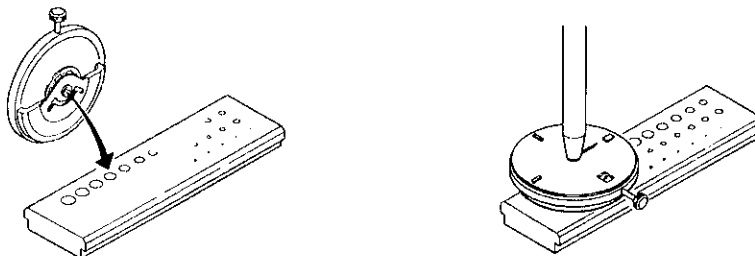

⑪ Setting wheel for first hour corrector

• How to install

Install the setting wheel for first hour corrector as shown below.

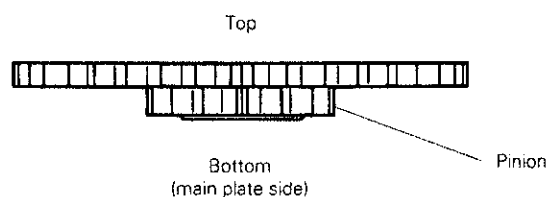

14 Hour wheel

• Lubricating

Refer to the illustrations below.

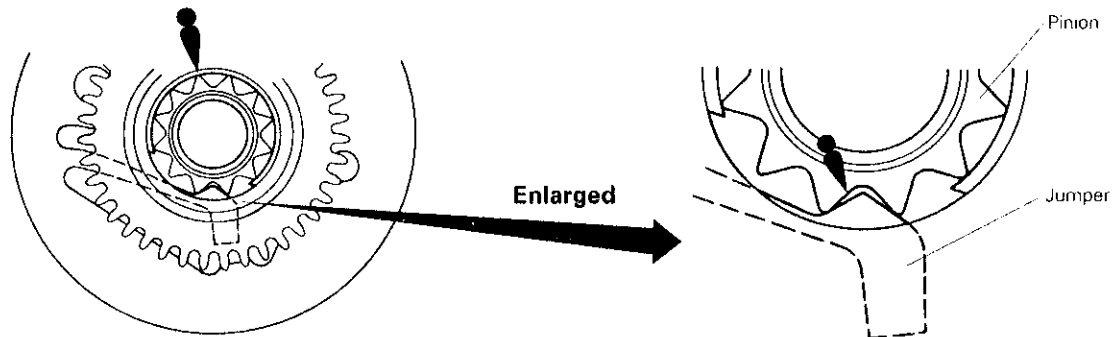

• How to install

Set the notched portion of the hour wheel ("A" portion in the illustration below) at the intermediate wheel for 24 hour hand side.

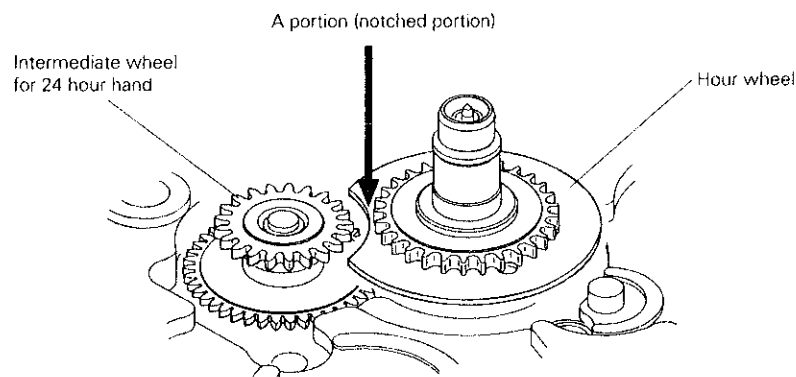

18 Oscillating weight screw

Tighten the oscillating weight screw very firmly, applying more force than usual.

Note: When tightening the oscillating weight screw, be careful not to press down on the movement hard with the screwdriver.

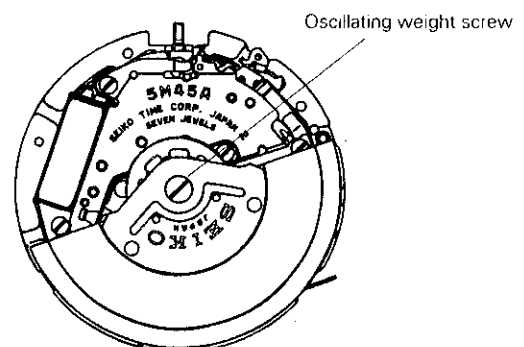

24 Capacitor unit

- Though the capacitor unit for Cal. 5M4 Series is of a completely different type than that for Cal. 5M2 Series, they have a close resemblance in shape. To prevent confusion between them, the capacitor unit for Cal. 5M4 Series has two holes for discrimination on its lead terminal portion. When replacing the capacitor unit, check for the holes to make sure you are using the proper one.
- Be sure to observe the correct polarity of the capacitor unit. The lead terminal side is the (-) side as shown in the illustration.
- To install the capacitor unit, set the "A" portion to the hole of the main plate, and then push the "B" portion so that it is fixed in position.

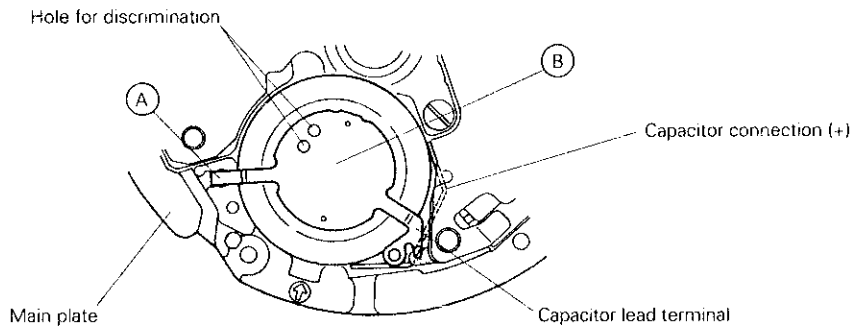

Note: Handle the capacitor unit with care so as not to short-circuit its (+) and (-) terminals.

26 Circuit block cover

The circuit block cover we are supplying has no calibre number nor numeral printed on it for discriminating the hand installation height.

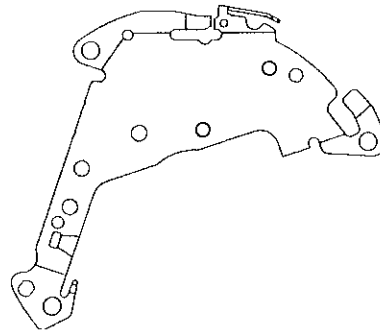

28 Oscillating weight bridge screw

29 Oscillating weight bridge

- Before tightening the oscillating weight bridge screw, check that the upper pivot of the generating rotor is inserted properly.
- Be sure to lubricate the upper and lower pivots of the generating rotor and intermediate wheel for generating rotor in the quantity specified in the illustration at right.

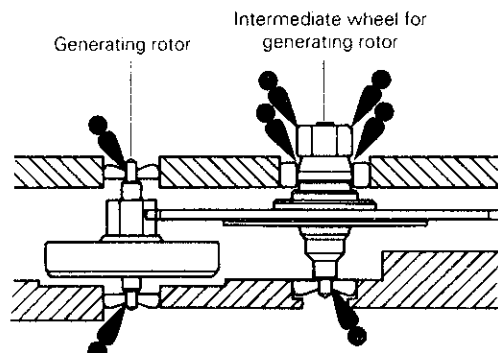

- Be sure to lubricate the ball-bearing of the oscillating weight bridge as shown in the illustration at right.

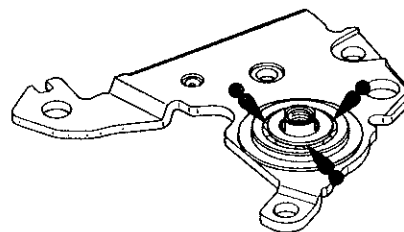

31 Intermediate wheel for generating rotor

- **Lubricating**

Refer to the illustration below.

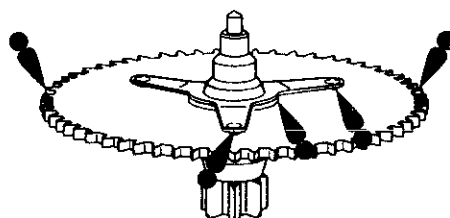

37 Train wheel bridge

- **Setting position**

Refer to the illustrations below to check where to install the respective wheels.

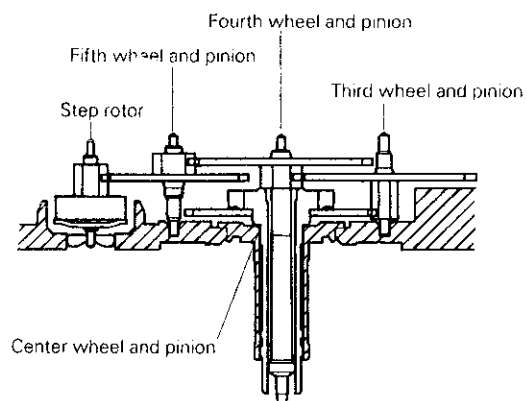
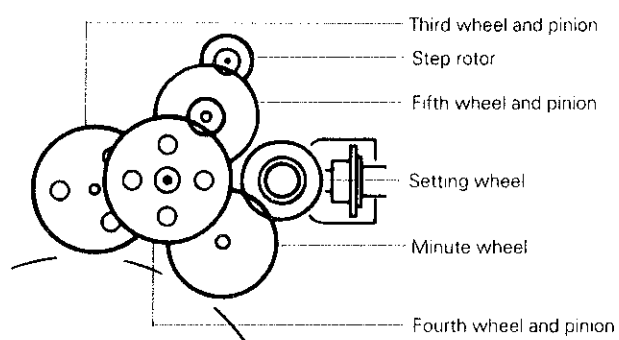

- ③⑧ Train wheel setting lever
- ④⑥ Switch lever
- ④⑦ Yoke
- ④⑧ Setting lever
- ④⑨ Lever for unlocking stem

• **Setting position and lubricating**

Refer to the illustration below.

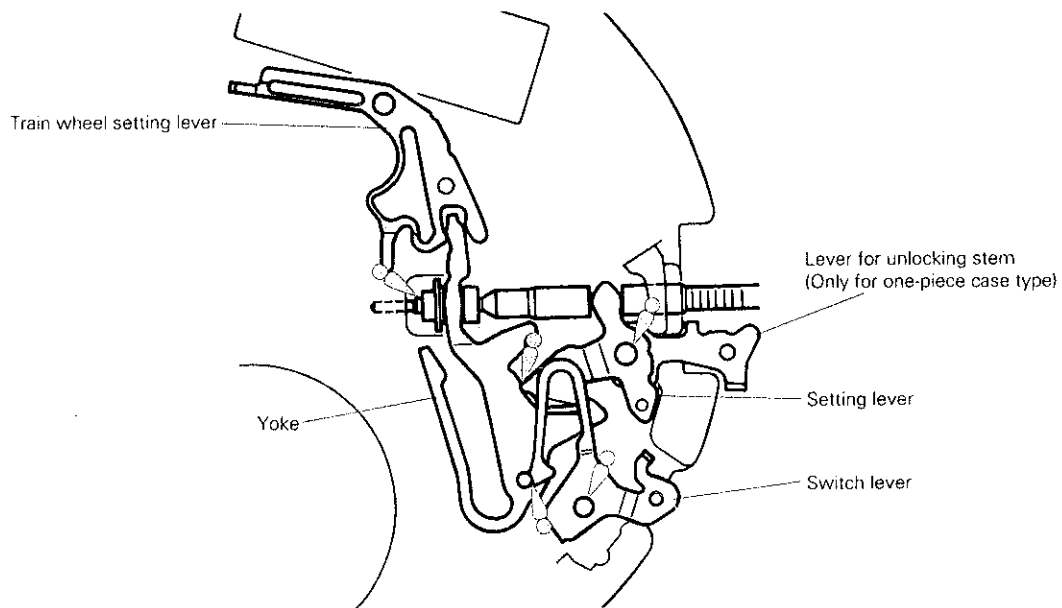

III. VALUE CHECKING AND ADJUSTMENT

• **Coil block resistance**

1.7 K Ω ~ 2.1 K Ω

• **Generating coil block resistance**

280 Ω ~ 380 Ω

• **Current consumption**

For the whole movement	:	Less than 1.0 μ A (with voltage supplied from a battery)
For the circuit block alone	:	Less than 0.5 μ A (with voltage supplied from a battery)

- **Measuring the current consumption for the whole movement**

- 1) Connect the tester as shown in the illustration.

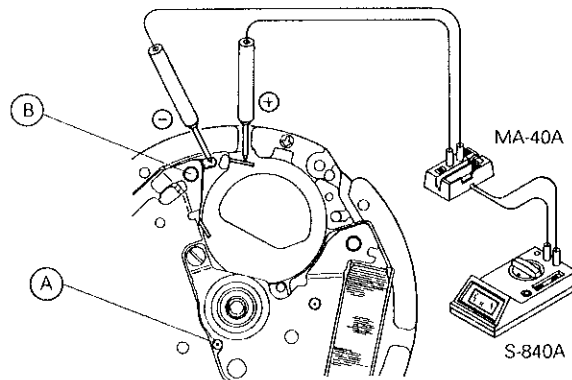

- 2) Start the measurement 30 to 40 seconds after connecting the tester, checking that a stable measurement is obtained.
- 3) When measuring, look through the upper hole jewel for step rotor (A in the illustration), to check that the step rotor is rotating at one-second intervals.

Note: If a stable measurement is not obtained for the current consumption, temporarily tighten the capacitor clamp screws at the hole (B) and then measure the current consumption again.

- **Measuring the current consumption for the circuit block alone**

Connect the tester to the input terminals (+) and (-) of the circuit block, and wait for 30 to 40 seconds before starting measurement.

Remarks:

When the current consumption exceeds the standard value for the whole movement but is within the standard value range for the circuit block alone, the watch is generating a driving pulse to compensate for the heavy load that may be applied to the gear train, etc.

In this case, overhaul and clean the movement parts and then measure current consumption for the whole movement again.

- **Checking the automatic generating system**

- 1) Apply the probes of the tester to the capacitor unit as shown in the illustration to measure the voltage.

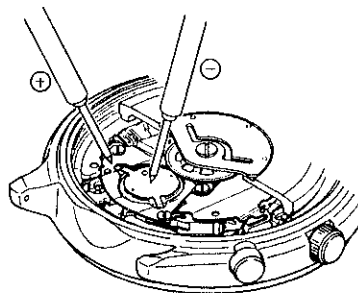

- 2) Close the case back temporarily, and swing the watch from side to side approximately 100 times rhythmically (at a rate of 2 to 3 times a second) with a snap of the wrist as shown in the illustration.

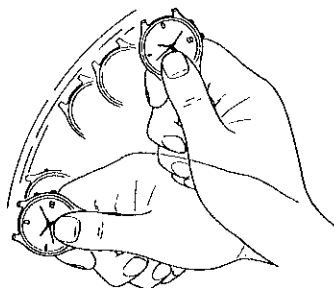

- 3) Remove the case back, and measure the voltage of the capacitor unit in the same manner as in step 1) above.
- 4) If the voltage obtained has increased more than 0.1 V from the initial voltage assuming that the initial voltage is within the range between 0.5 V and 1.0 V, the automatic generating system is operating normally.

* To recheck the automatic generating system, leave the watch untouched for more than 5 minutes, and then repeat steps 1) to 3) above.

Recharging information:

- Number of swings required and the duration of charge until the watch stops operating

Cal. 5M Series watches are equipped with a power reserve indicator. The current power reserve can be checked using the second hand at the press of the button at the 2 o'clock position. (The table below assumes that the initial voltage of the capacitor unit is 0.5 V.)

Number of swings	Duration of charge	Quick movement of the second hand when the power reserve indicator function is activated
100	Approx. 6 hours	5 seconds
400	Approx. 2 days	10 seconds
700	Approx. 4 days	20 seconds
1,100	Approx. 7 days	30 seconds

Notes:



1. If the voltage of the capacitor unit fluctuates, the movement of the second hand may not indicate the actual power reserve. To check the relationship between the number of swings and the duration of charge, use the power reserve indicator more than one hour after swinging the watch the number of times specified in the above table, and then check if the watch keeps operating for the indicated duration of charge.
2. Cal. 5M45A is so designed that the capacitor can be charged up to 2.2 V. Even if the watch is fully charged, however, the power reserve indicator can only indicate that the capacitor voltage is more than 1.55 V, which corresponds to 7 days of duration of charge, with the second hand showing 30 seconds of quick movement. The actual duration of charge is more than 7 days when the watch is fully charged.

HOW TO DISASSEMBLE/REASSEMBLE Cal. 5M/3M series One-piece and Plastic Case Type

Disassembling procedures Figs. : ① → ⑦ (⑧ for Cal. 3M Series)

Reassembling procedures Figs. : ⑦ (⑧ for Cal. 3M Series) → ①

Lubricating:

Types of oil
 Silicone oil 500,000 c.s.
 LOCTITE 241

Oil quantity

 normal quantity

Cal. 5M Series One-piece Case Type

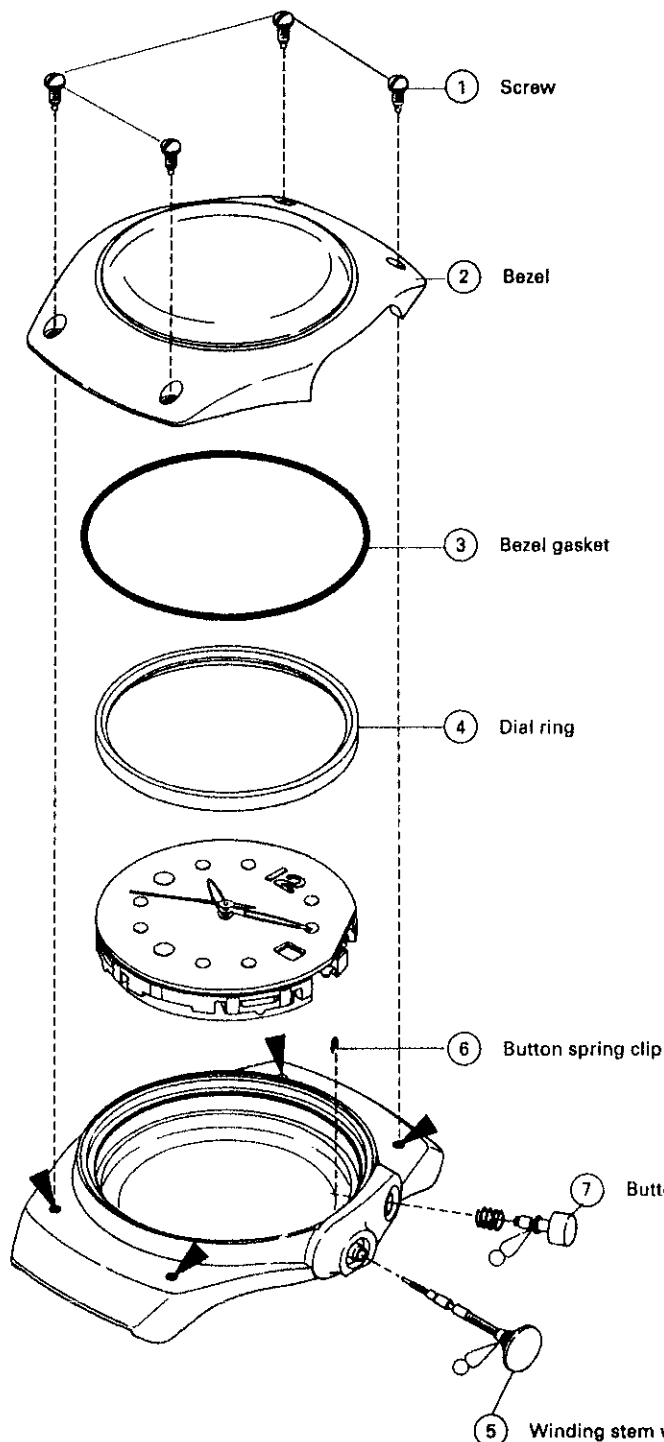

Cal. 3M Series One-piece Case Type

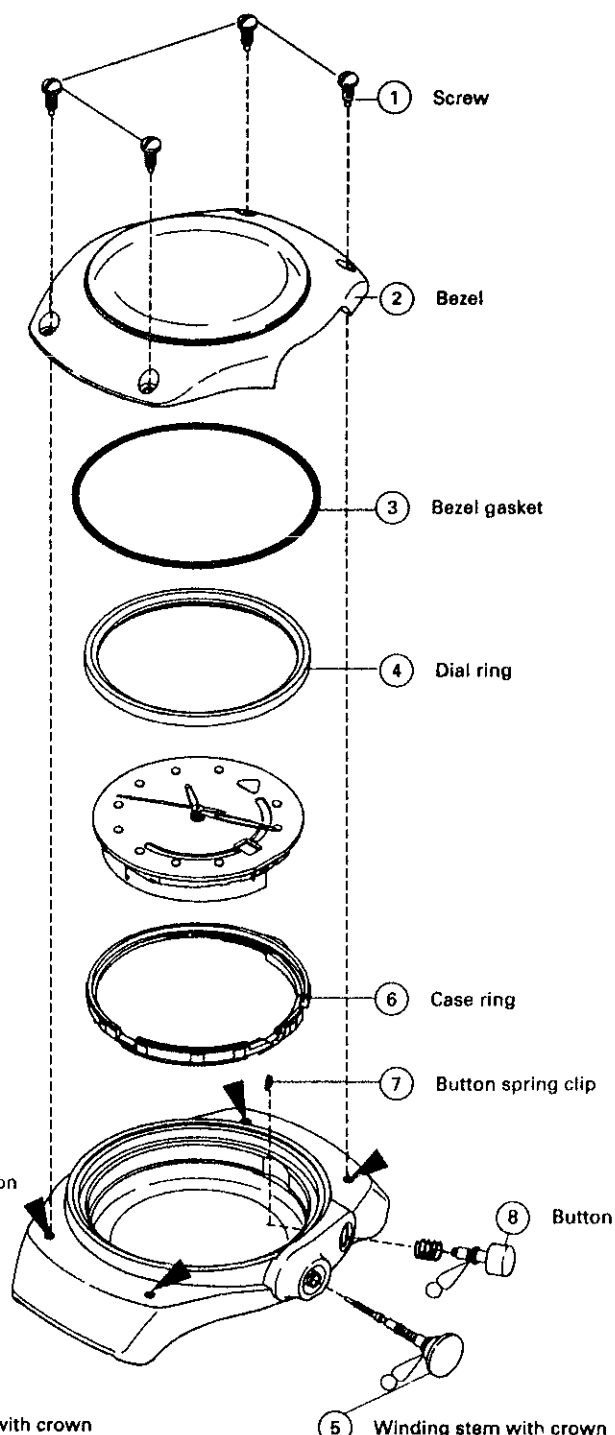

* It is not necessary to lubricate the bezel gasket with silicone oil before reassembling. Remove dust completely instead.

* For the code number of the casing parts, refer to "SEIKO Casing Parts Catalogue".

REMARKS ON DISASSEMBLING AND REASSEMBLING THE ONE-PIECE CASE TYPE

① Screw (Bezel fixing screw)

• Notes on the adhesive

- An adhesive is used to prevent the screws from loosening.
- For this purpose, be sure to use LOCTITE 241, which is manufactured by Loctite Co., Ltd.
- Never use any other adhesive than LOCTITE 241, such as S-312, for band adjusting screws. Otherwise, the screws may not be removed, or they may be easily loosened when given a shock, thus deteriorating the water resistant quality.

• How to fix the screws with adhesive

- 1) Clean the screws and screw holes of the case with alcohol and so on to remove the remaining adhesive, moisture, oil and soil sticking to them.
- 2) Before setting the movement to the case, apply a proper quantity of adhesive to the screw holes of the case as shown in the illustration at right.
- 3) After setting the movement and bezel to the case, tighten the bezel fixing screws securely.
 - After tightening a screw, then, tighten the screw positioned diagonally to it as illustrated at right. Likewise, tighten the remaining two screws.
 - After tightening all the screws, tighten them further once again to make sure.
- 4) Leave the case at normal temperature for a day until the adhesive hardens.

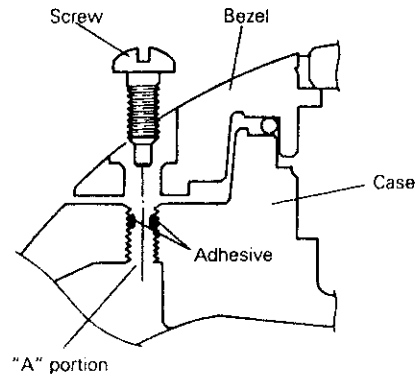

Notes:

- Be sure to use a driver corresponding to the screw size (No.22), and take care not to damage the slot of the screw, bezel and case when tightening the screws.
- Do not apply the adhesive in so large a quantity as to be pressed out by the screws and stick to the rear of the case ("A" portion in the illustration at right) and other parts. If the adhesive has been pressed out, dry it with paper or clean it with alcohol.
- Be sure to check that any adhesive pressed out of the screw holes will not get inside the case.

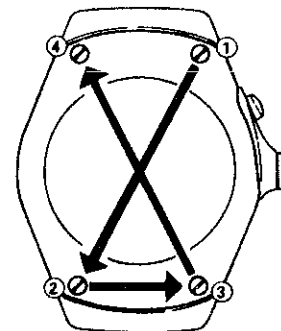

Example procedure of tightening the screws

⑤ Winding stem with crown

While pressing down the lever for unlocking stem with the tip of tweezers as illustrated at right, pull out the winding stem with crown.

	Lever for unlocking stem
Cal. 5M Series	0397 660
Cal. 3M Series	0397 670

Note:

- To remove the movement from the case after pulling out the winding stem with crown, pry up the holding ring for dial little by little with the tip of tweezers. Do not lift up the dial itself to remove the movement.

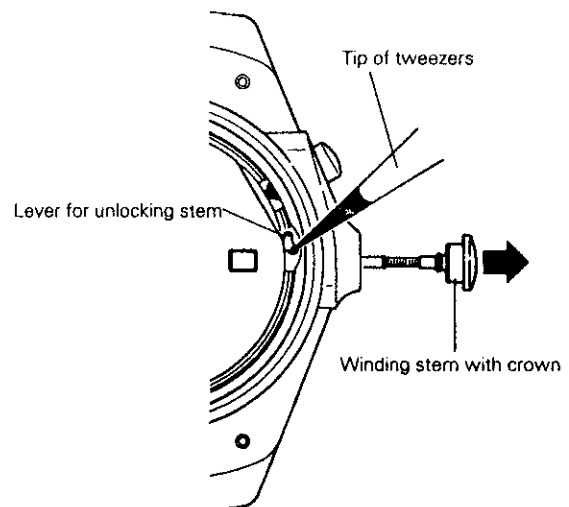

Disassembling procedures Figs. : ① → ⑦ (⑨ for Cal. 3M Series)

Reassembling procedures Figs. : ⑦ (⑨ for Cal. 3M Series) → ①

Lubricating:

Types of oil

Oil quantity

 Silicone oil 500,000 c.s.

 normal quantity

Cal. 5M Series Plastic Case Type

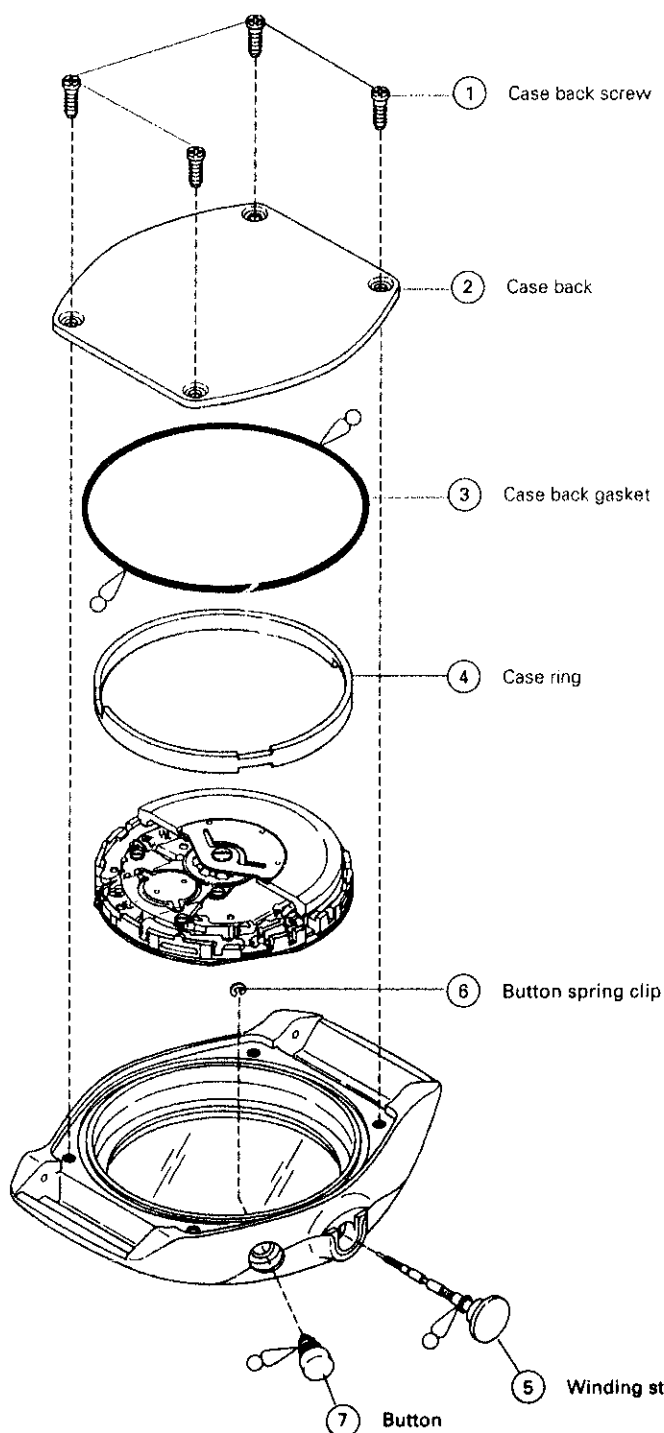

Cal. 3M Series Plastic Case Type

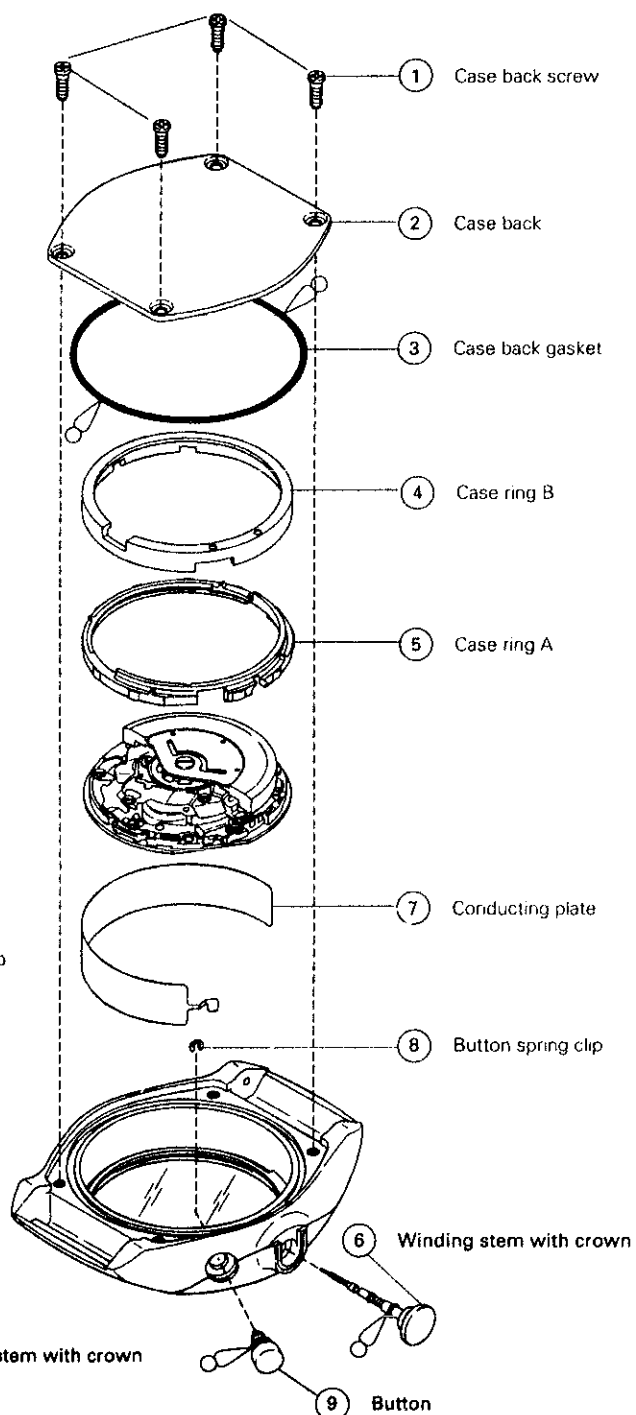

* For the code number of the casing parts, refer to "SEIKO Casing Parts Catalogue".

REMARKS ON DISASSEMBLING AND REASSEMBLING THE PLASTIC CASE TYPE

Cal. 5M Series

④ Case ring

The case ring can be installed with either side up. To install it, set the portion having notches on both up and down sides ("A" portion in the illustration) to the button position at the 2 o'clock side.

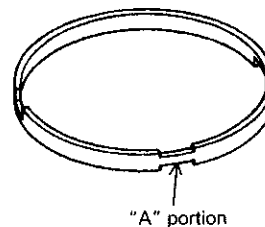

Cal. 3M Series

④ Case ring B

Set the case ring B in such a manner that the notched portion "a" in the illustration is at the 12 o'clock side and the round holes "b" and "c" are at the button and crown sides, respectively.

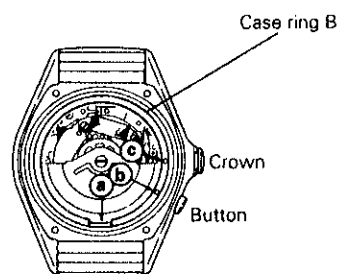

⑤ Case ring A

Set the case ring A in such a manner that the notched portions "d", "e" and "f" in the illustration are at the 6 o'clock, button and crown sides, respectively.

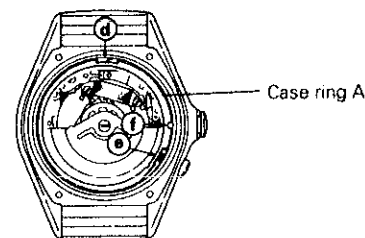

⑦ Conducting plate

- Do not disassemble the conducting plate except when necessary.
- Cal. 3M Series watches of the metal case type use the case as the conducting route of the (+) terminal of the indicator switch. For the plastic case type models, a conducting plate is installed inside the case to secure the conducting route.

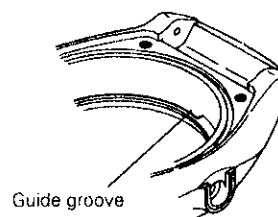

• How to install

- A guide groove for the conducting plate is provided along the inner surface of the case.
- Set the end of the conducting plate to the end portion of the guide groove located at the 6 o'clock side of the case, and then, install the conducting plate little by little to the case along the groove.
- Check that the hooked terminal portion of the conducting plate securely makes contact with the terminal portion of the button, and that the conducting plate closely makes contact with the inner surface of the case.

End portion of the guide groove at the 6 o'clock side

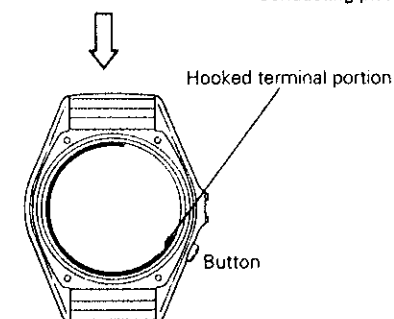
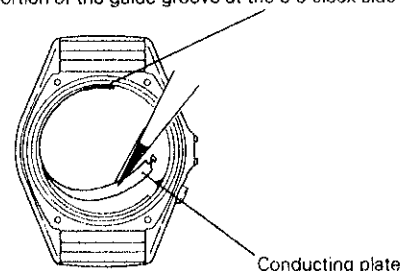

Note: Take care not to bend or deform the conducting plate.