

Cal. 6106A

Characteristics

Casing diameter: 27.00^φ mm
 Maximum height: 5.15 mm
 Vibrations per hour: 21,600
 Automatic winding with sweep second
 Calendar (day & date)
 Pushing instant date setting
 Second-setting device
 "Diashock" Shock Resistant Device

112611

122611

161805

171611

205613

213612

401615

224611

225611

231610

241611

251611

301611

310611

315611

331610

341611

345611

261611

271611

281611

282611

285611

381611

383611

384611

387611

388611

391610

☆ 397610

014363

014364

014365

011210

014317

354615

505611

823611

831611

839610

632610

802610

810610

817610

868610

880610

808610

883610

963610

193612

500613

☆ 870610

☆ 801610

☆ 801612

☆ 884611

022150	022252	022257	022266	022351	022467	022468	022469
022470	022471	022662	022677	022758	022760	022773	2/1

Calibre No.	Jewels	Style Name	
6106A	25j		
PART NO.	LIST OF MATERIALS	PART NO.	LIST OF MATERIALS
112611	Barrel & train-wheel bridge	☆ 801610	Date dial
122611	Center wheel bridge	☆ 801612	Date dial
161805	Pallet cock	802610	Date driving wheel
171611	Balance cock	808610	Date dial guard
193612	Framework for automatic device with ball-bearing	810610	Date jumper
205613	Complete barrel with arbor	817610	Intermediate date wheel
213612	Barrel arbor	868610	Day finger
224611	Center wheel & pinion with cannon pinion	☆ 870610	Day star with dial disk (English letters)
225611	Cannon pinion	880610	Date corrector
231610	Third wheel & pinion	883610	Date corrector spring
241611	Sweep second wheel & pinion	☆ 884611	Holding ring for dial
251611	Escape wheel & pinion	963610	Snap for day star with dial disk
261611	Minute wheel	022150	Stud screw
271611	Hour wheel	022252	Holder screw for transmission wheel & pawl lever
281611	Setting wheel	022257	Date corrector spring screw
282611	Clutch wheel	022266	Minute wheel bridge screw
285611	Ratchet wheel	022351	Center wheel bridge screw
301611	Jewelled pallet fork & staff	022467	Ratchet wheel screw
310611	Balance complete with stud	022468	Pallet cock screw
315611	Balance staff	022469	Bridge screw
331610	Roller with jewel	022470	Framework screw for automatic device with ball-bearing
341611	Regulator	022471	Click screw
345611	Stud holder	022662	Setting lever spring screw
354615	Winding stem	022677	Screw for day & date driving wheel
381611	Click	022758	Dial screw
383611	Setting lever with axle	022760	Date dial guard screw
384611	Yoke (Clutch lever)	022773	Screw for oscillating weight
387611	Minute wheel bridge	011145	Upper hole jewel for center wheel
388611	Setting lever spring	011146	Lower hole jewel for center wheel
391610	Second-setting lever	011306	Upper hole jewel for 3rd wheel
☆ 397610	Lever for unlocking stem	011306	Lower hole jewel for 3rd wheel
401615	Mainspring with slipping attachment	011306	Upper hole jewel for sweep second wheel
014363	Diashock upper frame	011406	Upper hole jewel for escape wheel
014364	Diashock lower frame	011406	Lower hole jewel for escape wheel
014365	Diashock hole jewel with frame	011503	Upper hole jewel for pallet
011210	Diashock cap jewel	011503	Lower hole jewel for pallet
014317	Diashock spring	011147	Upper hole jewel for transmission wheel
500613	Oscillating weight	011147	Lower hole jewel for transmission wheel
505611	Transmission wheel	023150	Tube for pallet cock screw (Cylinder type)
823611	Eccentric post	023151	Tube for bridge screw
831611	Pawl lever with jewel	023170	Tube for pallet cock screw (Recessed type)
839610	Holder for transmission wheel & pawl lever	023171	Tube for framework screw of automatic device
632610	Date corrector finger		

Remarks :

Lever for unlocking stem
 ☆ 397610 ... Used for the one-piece waterproof case.
 If the lever for unlocking stem is required in any other type, specify the dial No. or the case No.

Date dial
 ☆ 801610 ... Black figures on white background } Used when the crown is located at 4 o'clock and the
 ☆ 801612 ... Black figures on gilt background } at 3 o'clock.
 If the date dial is required in any other type, specify ① the Cal. No. ② the crown position
 ③ the date frame position and ④ the dial No.

Day star with dial disk
 ☆ 870610 ... Used when the crown is located at 4 o'clock and the day frame at 3 o'clock.
 If the day star with dial disk is required in any other type, specify the number printed on the disk.

Holding ring for dial
 ☆ 884611 ... Used for watches except one-piece waterproof watch.
 If the holding ring for dial is required in any other type, specify the dial No. or the case No.

☆ ⇨ Please see remarks on the reverse page.

☆ ⇨ Please see remarks.
 Items in light letters are not shown in photos.

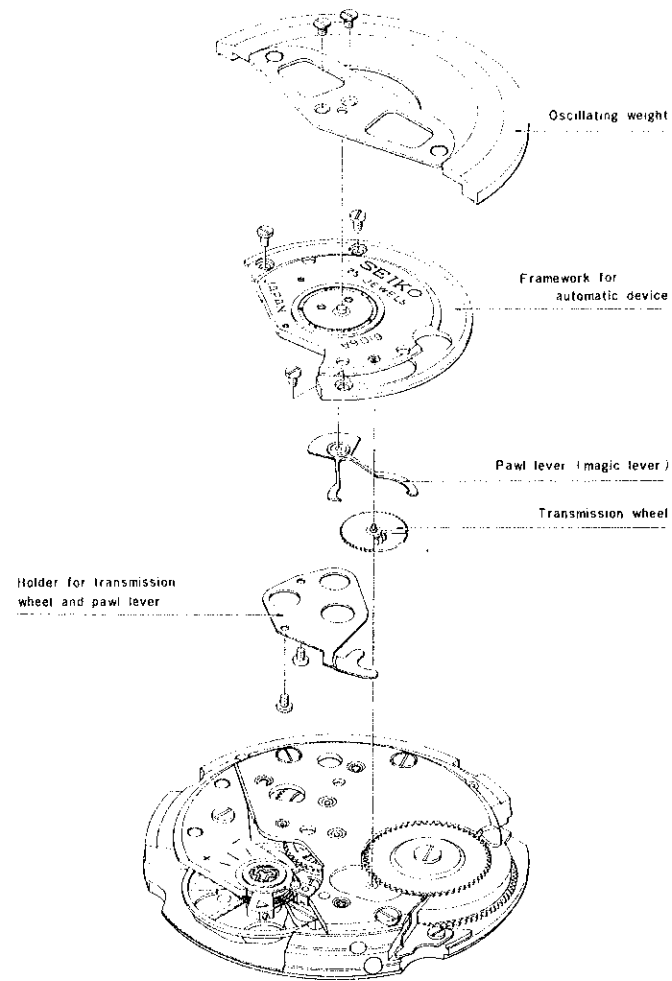
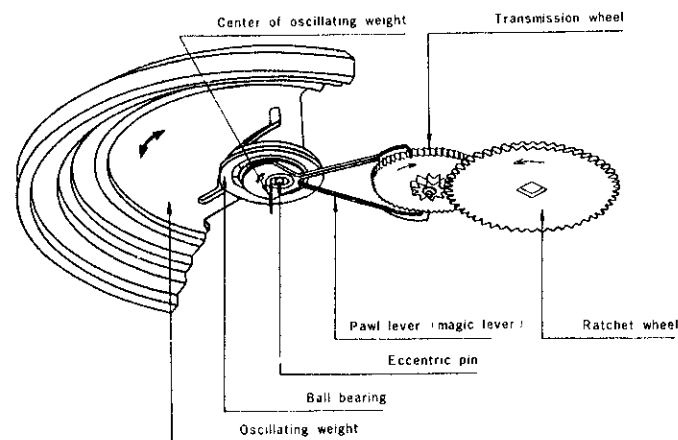

Fig. 1



Note: Since the ball bearing is attached firmly on the framework for automatic device, it cannot be removed.

Fig. 2

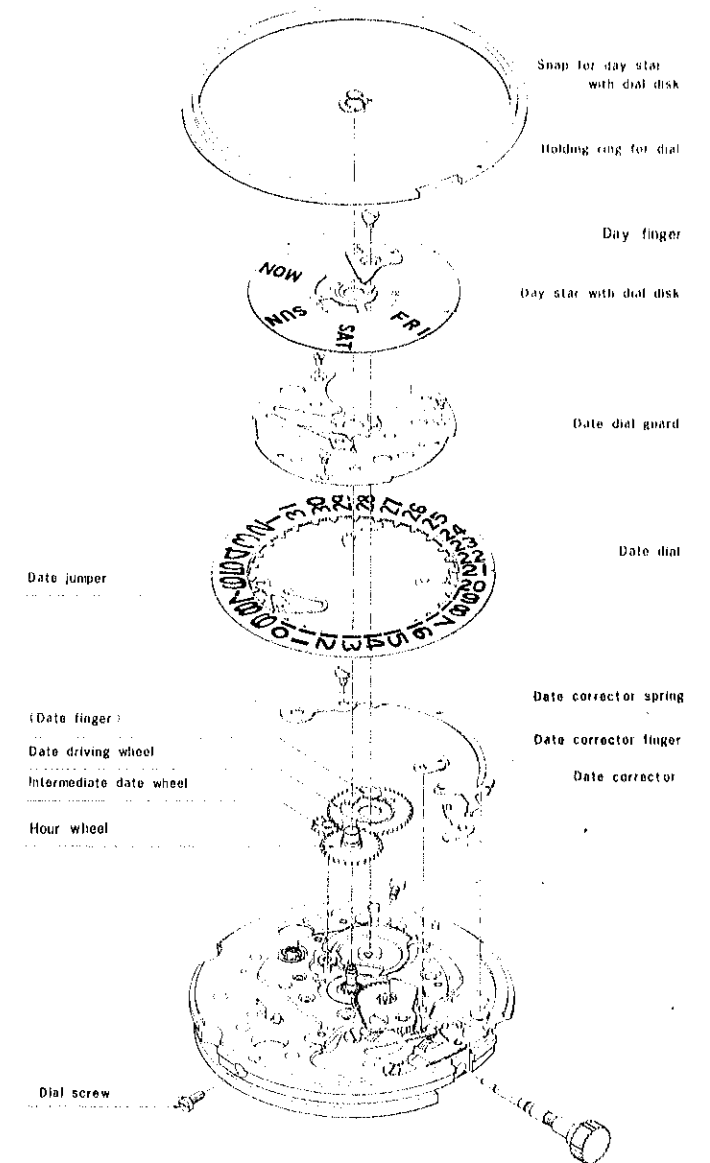

Fig. 3

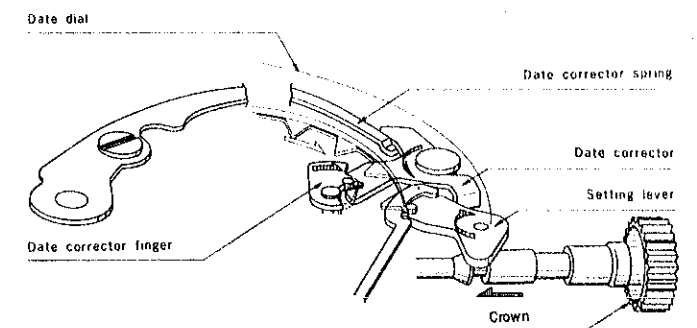

Fig. 4

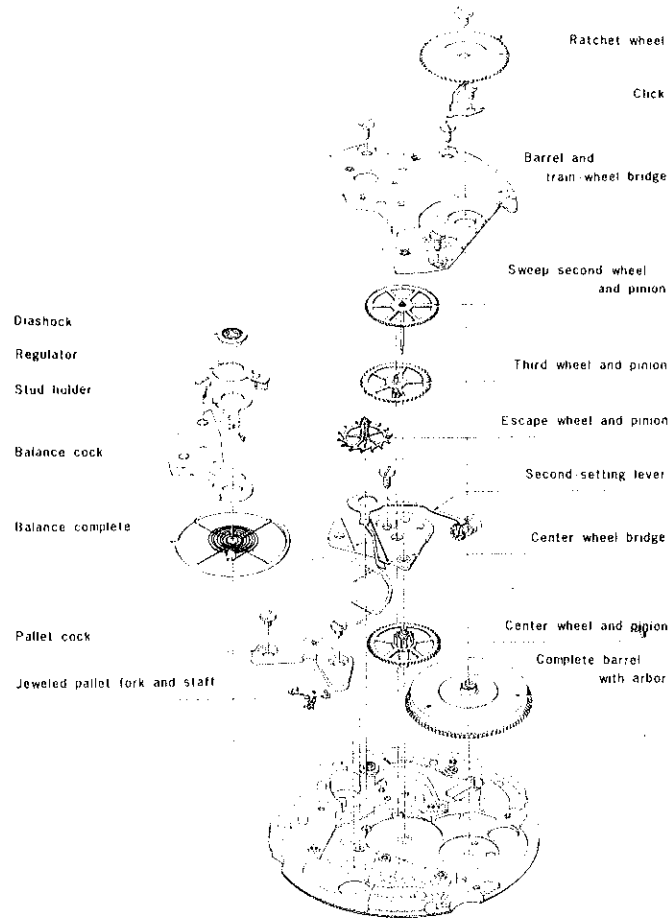
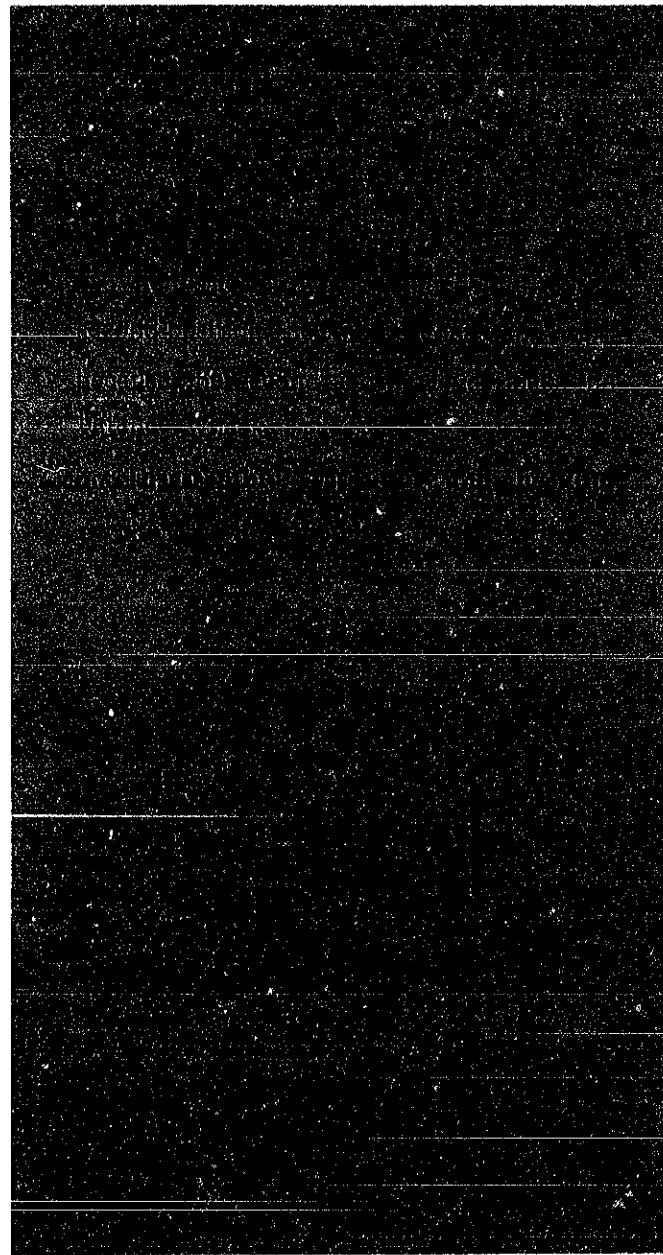

Fig. 5

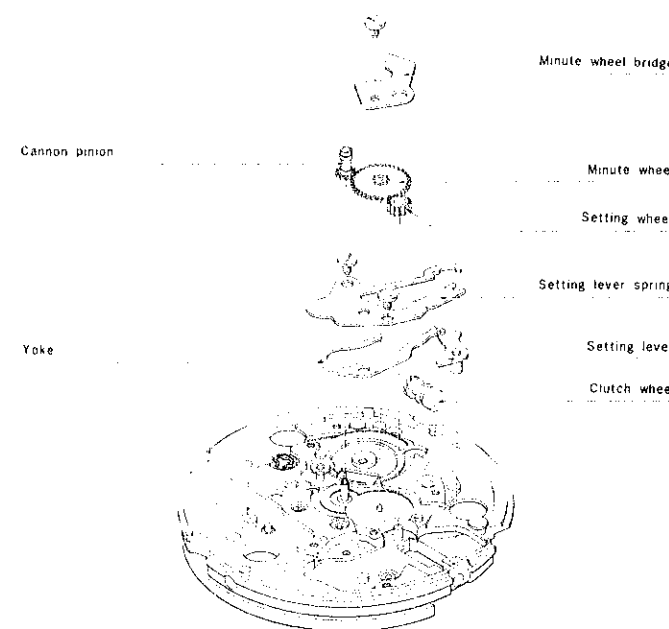

Fig. 6

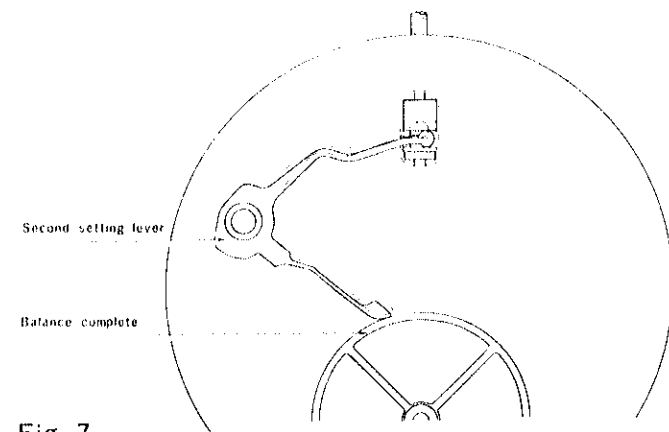
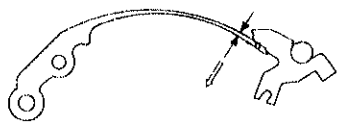
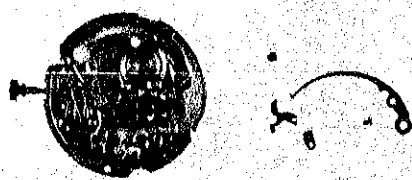
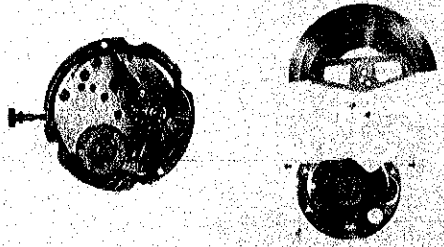
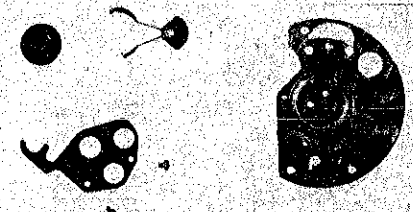
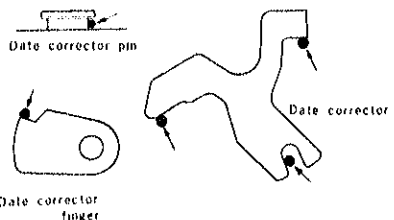

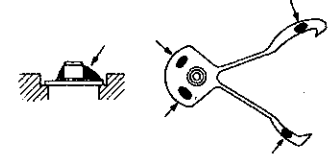

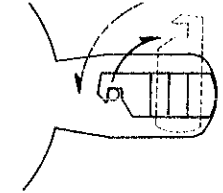
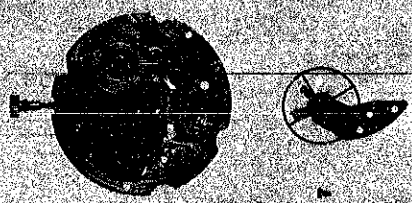

Fig. 7



	1	2	3
Disassembly	DIAL 1) Remove sweep second, minute, and hour hands 2) Remove dial after loosening dial screw 3) Remove holding ring for dial 4) Remove snap for day star with dial disk (refer to photo in remarks). (Use small driver, then gradually pry open entire circumference to prevent deforming dial.)	DATE DIAL 1) Remove date dial guard screws (3 pcs.) 2) Remove date dial guard 3) Remove date dial 4) Remove date jumper	DATE DRIVING WHEEL 1) Remove hour wheel 2) Remove intermediate date wheel 3) Remove date driving wheel screw 4) Remove day finger 5) Remove date driving wheel
		When removing date dial guard, sometimes date corrector finger will be dislodged with date dial guard.	
Assembly	DIAL 1) Set day star with dial disk, then assemble snap for day star with dial disk after interlocking it with day jumper (refer to photo in remarks) 2) Set holding ring for dial 3) Set dial and fasten dial screw 4) Set hour, minute, and sweep second hands 5) Check forwarding condition of day star with dial disk	DATE DIAL 1) Lubricate plate, date dial set position 2) Set date dial 3) Lubricate date jumper (refer to the lower drawing) 4) Set date jumper 5) Set date dial guard and fasten screws (3 pcs.) 6) Check condition of date corrector and date driving	DATE DRIVING WHEEL 1) Lubricate axles of intermediate date wheel and date driving wheel (Moebius Synt-A-Lube) 2) Set day driving finger on date driving wheel and fasten date driving wheel screw (stepped screw) 3) Set intermediate date wheel and hour wheel

6106A Disassembly and assembly—continued

6106A Disassembly and assembly—continued

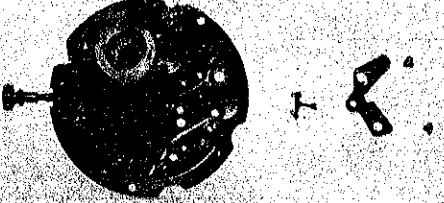
	4 DATE CORRECTOR	5 FRAMEWORK FOR AUTOMATIC DEVICE	6 PAWL LEVER
Disassembly Method	<ol style="list-style-type: none"> 1) Remove date corrector spring screw, then hold date corrector spring with tweezers and remove spring in direction of arrow (refer to lower drawing) 2) Remove date corrector finger 3) Remove date corrector 	<ol style="list-style-type: none"> 1) Check winding condition of mainspring by revolving oscillating weight 2) Remove oscillating weight screws (2 pcs.) 3) Remove oscillating weight. 4) Remove screws (3 pcs.) then remove framework for automatic device 	<ol style="list-style-type: none"> 1) Remove holder screws (2 pcs.) for transmission wheel and pawl lever 2) Remove holder 3) Remove pawl lever and transmission wheel
Remark		<p>Checking) When making one slow revolution of oscillating weight while observing meshing of pawl lever and transmission wheel through an eye glass confirm whether or not slip in meshing exceeds four teeth. When slip is under four teeth, check shapes of eccentric pin and pawl lever.</p>	
Photo			
Assembly Method	<ol style="list-style-type: none"> 1) Lubricate date corrector and date corrector pin (Moebius grease "Remontoires" or watch oil S-4) 2) Set date corrector 3) Set date corrector spring and fasten screw 4) Hold tip of date corrector spring with tweezers, then insert it under date corrector 5) Set date corrector finger 6) Lubricate date corrector finger (Moebius Synt-A-Lube) 	<ol style="list-style-type: none"> 1) Set framework for automatic device and screws 2) Lubricate teeth and upper pivot of transmission wheel (watch oil S-4) 3) Set oscillating weight and its screws (2 pcs.) 4) Check operating condition of automatic winding section. (Confirm that oscillating weight is not scraping framework; then confirm revolution of oscillating weight tilting movement in a fully-wound condition) 	<ol style="list-style-type: none"> 1) Lubricate ball-bearing (Moebius Synt-A-Lube at above three points) 2) Lubricate eccentric pin (watch oil S-4) 3) Set transmission wheel 4) Set pawl lever 5) Lubricate lower pivot of transmission wheel and pawl lever (watch oil S-4, Moebius grease "Remontoires") 6) Set holder for transmission wheel and pawl lever and fasten screws (2 pcs.) 7) Check to ensure pawl of pawl lever has not come off transmission wheel
Remark			 <p>Perform correct lubrication of eccentric pin</p>

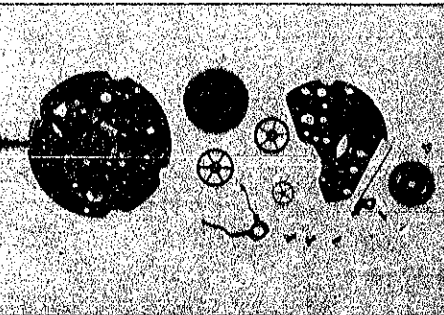
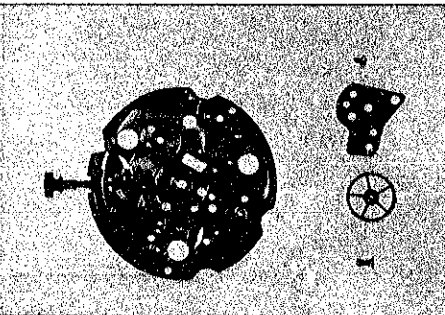
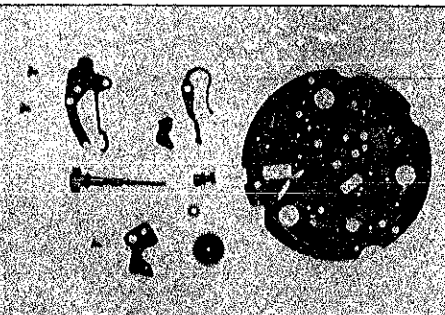
	7 BALANCE COCK	8 BALANCE COMPLETE	9 PALLET
Disassembly Method	<ol style="list-style-type: none"> 1) Remove balance cock screw 2) Remove balance cock 	<ol style="list-style-type: none"> 1) Turn regulator key in direction of arrow. (If regulator key is revolved in opposite direction, stud will become bent due to special shape of regulator key) 2) Loosen stud screw 3) Remove balance complete from cock 	<ol style="list-style-type: none"> 1) Loosen mainspring 2) Remove pallet cock 3) Remove pallet
Remark			
Photo			
Assembly Method	<ol style="list-style-type: none"> 1) Set balance cock and fasten screw 2) Check condition of hairspring (for horizontality, unbalance) 3) Check second-setting condition 	<ol style="list-style-type: none"> 1) Set balance on balance cock, placing stud at hole of stud holder 2) Insert hairspring between regulator key and regulator pin, then turn regulator key in direction of arrow until it comes to correct position (Refer to drawing in disassembling remarks) (If turned excessively, balance will strike stud and may damage it) 	<ol style="list-style-type: none"> 1) Set pallet after lubricating pallet jewels (Moebius Synt-A-Lube) 2) Check pallet operating condition plus meshing of the jewel and escape wheel (A check of jewel meshing should be performed after slightly winding mainspring)
Remark	<p>Do not perform assembly of balance complete at second position (during second-setting) of winding system pull out; always perform it at first position</p>	<p>Do not widen space between regulator pin and regulator key. Do not deform hairspring.</p>	

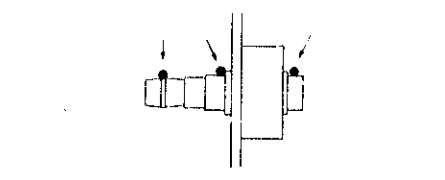
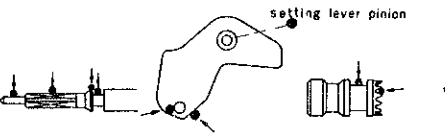
Disassembly	10	TRAIN WHEELS	11	CENTER WHEEL AND PINION	12	SHIFTING MECHANISM
	<ol style="list-style-type: none"> 1) Remove ratchet wheel 2) Remove click 3) Remove barrel & train wheel bridge 4) Remove sweep second & pinion, third wheel & pinion, escape wheel & pinion and barrel 5) Remove second-setting lever 		<ol style="list-style-type: none"> 1) Remove cannon pinion 2) Remove center wheel bridge 3) Remove center wheel and pinion 		<ol style="list-style-type: none"> 1) Remove minute wheel bridge 2) Remove minute wheel 3) Remove setting wheel 4) Remove setting lever spring 5) Remove yoke (clutch lever) 6) Remove setting lever 7) Remove winding stem, then remove clutch wheel 	
Remark						
Photo						
Assembly	4	TRAIN WHEELS	3	CENTER WHEEL AND PINION	2	SHIFTING MECHANISM
	<ol style="list-style-type: none"> 1) Set second setting lever (this time, crown should be set at first position) 2) Set barrel after lubricating barrel arbor (Moebius grease "Remontoires" or watch oil S-4) 3) Set third wheel & pinion, escape wheel & pinion 4) Set sweep second wheel & pinion after lubricating it (Moebius Synt-A-Lube) 5) Set barrel & train wheel bridge and its screws 6) Set click and its screw 7) Set ratchet wheel and its screw 8) Check revolving condition of train wheels 9) Lubricate each pivot or hole jewel on sweep second wheel & pinion, third wheel & pinion and escape wheel & pinion (Moebius Synt-A-Lube) 		<ol style="list-style-type: none"> 1) Set center wheel & pinion after lubricating it (Moebius grease "Remontoires" or watch oil S-4) 2) Set center wheel bridge and its screw 3) Set cannon pinion 		<ol style="list-style-type: none"> 1) Lubricate clutch wheel and winding stem, then set them on plate (Moebius grease "Remontoires" or watch oil S-4) 2) Set setting lever after lubricating (Moebius grease "Remontoires" or watch oil S-4) 3) Set yoke (clutch lever) 4) Set setting lever spring and its screw 5) Lubricate minute wheel pin, setting wheel axle, (Moebius Synt-A-Lube) 6) Set setting wheel 7) Set minute wheel, minute wheel bridge, and its screws 	
Remark						

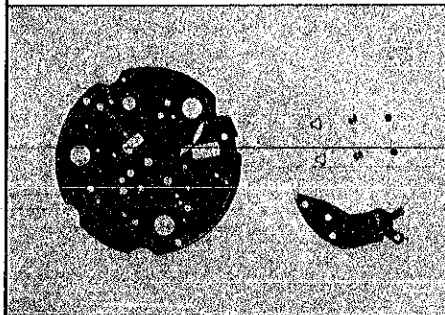
Disassembly	13	DIASHOCK	14	CLEANING
	<ol style="list-style-type: none"> 1) Remove Diashock spring, cap jewel, and hole jewel with frame 2) Clean these parts 		<p>Clean all parts so far disassembled For further details refer to "Cleaning of parts"</p>	
Remark	<p>Concerning disassembling procedures, refer to common items on Diashock</p>			
Photo				
Assembly	1	DIASHOCK		
	<ol style="list-style-type: none"> 1) Set Diashock hole jewel frame, cap jewel, and spring on plate and balance cock 2) Lubricate these parts 			
Remark	<p>Concerning lubricating method and assembling method of plate for Diashock, refer to common items on Diashock</p>			