

TECHNICAL GUIDE

SEIKO
QUARTZ

CAL. 6922A
CAL. 6923A

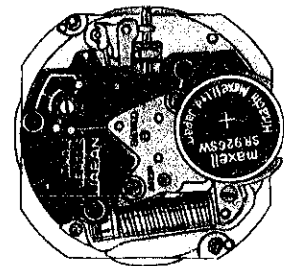
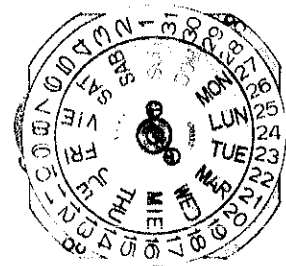

CONTENTS

I. SPECIFICATIONS	1
II. STRUCTURE OF THE CIRCUIT BLOCK	1
III. DISASSEMBLING, REASSEMBLING AND LUBRICATING	2
1. Hour, minute, and second hands ~ center minute wheel	2
2. Coil block screw ~ crystal unit cushion	3
3. Train wheel bridge screw ~ clutch wheel	4
IV. CHECKING AND ADJUSTMENT	5
• Check output signal	5
• Check hand setting condition	5
• Check battery voltage	5
• Check battery conductivity	5
• Check circuit block conductivity	5
• Check coil block	5
• Check gear train mechanism	5
• Check setting and calendar mechanism	5
• Check reset and train wheel setting conditions	6
• Check accuracy	7
• Check current consumption	7
• Check water resistance	8
• Check battery life indicator	8
• Check appearance and functioning	8

I. SPECIFICATIONS

Item		Cal. No.	6922A	6923A
Time indication			3 hands	
Additional mechanism			Date	Day and date
			Instant date setting device	Instant day and date setting device
			Train wheel setting device	
			Electronic circuit reset switch	
			Battery life indicator	
Loss/gain			Loss/gain at normal temperature range Monthly rate: less than 15 seconds	
Movement size	Outside diameter		$\phi 25.3$ mm (21.7 mm between 3 o'clock and 9 o'clock) 22.0 mm between 6 o'clock and 12 o'clock)	
	Casing diameter		$\phi 22.0$ mm	
	Height		2.3 mm	2.5 mm
Regulation system			Trimmer condenser	
Measuring gate by quartz tester			Any gate is available.	
Battery			Maxell SR926SW, SEIKO (SEIZAIKEN) TR926SW Battery life is approximately 5 years. Voltage: 1.55V	
Jewels			2 jewels	

II. STRUCTURE OF THE CIRCUIT BLOCK

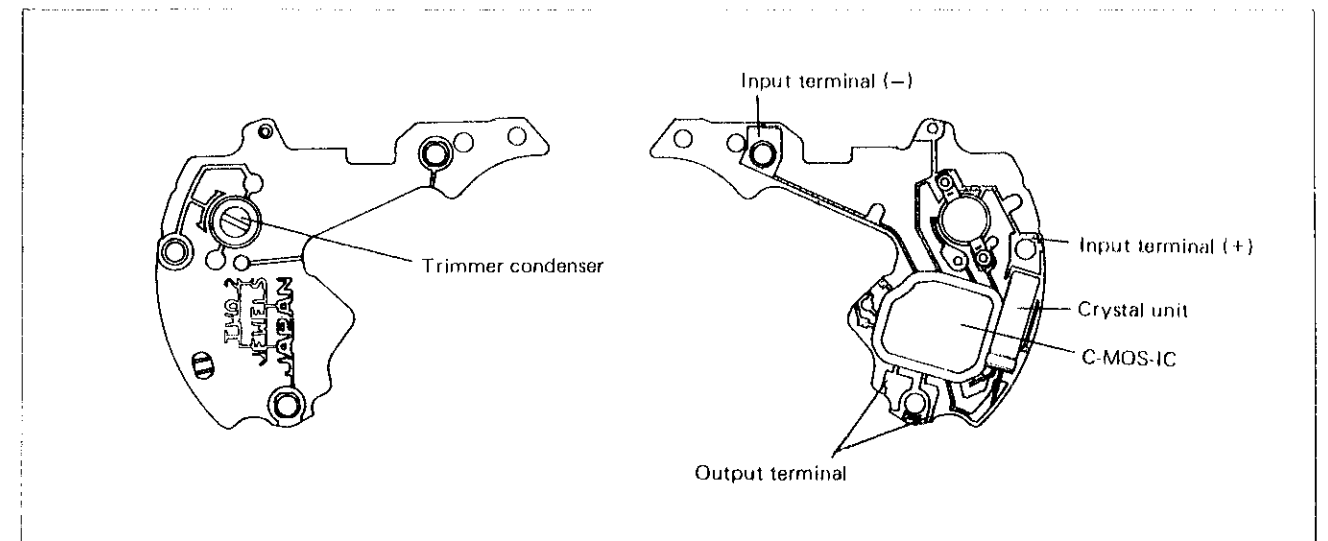

III. DISASSEMBLING, REASSEMBLING AND LUBRICATING

Disassembling procedures Figs. : ① ~ ④⑤

Reassembling procedures Figs. : ④⑤ ~ ①

Lubricating:	Types of oil	Oil quantity
	● Moebius A	▶ Extremely small
	○ SEIKO Watch Oil S-6	▶ Normal

● Use the movement holder S-666 for disassembling and reassembling.

1. Hour, minute, and second hands ~ center minute wheel

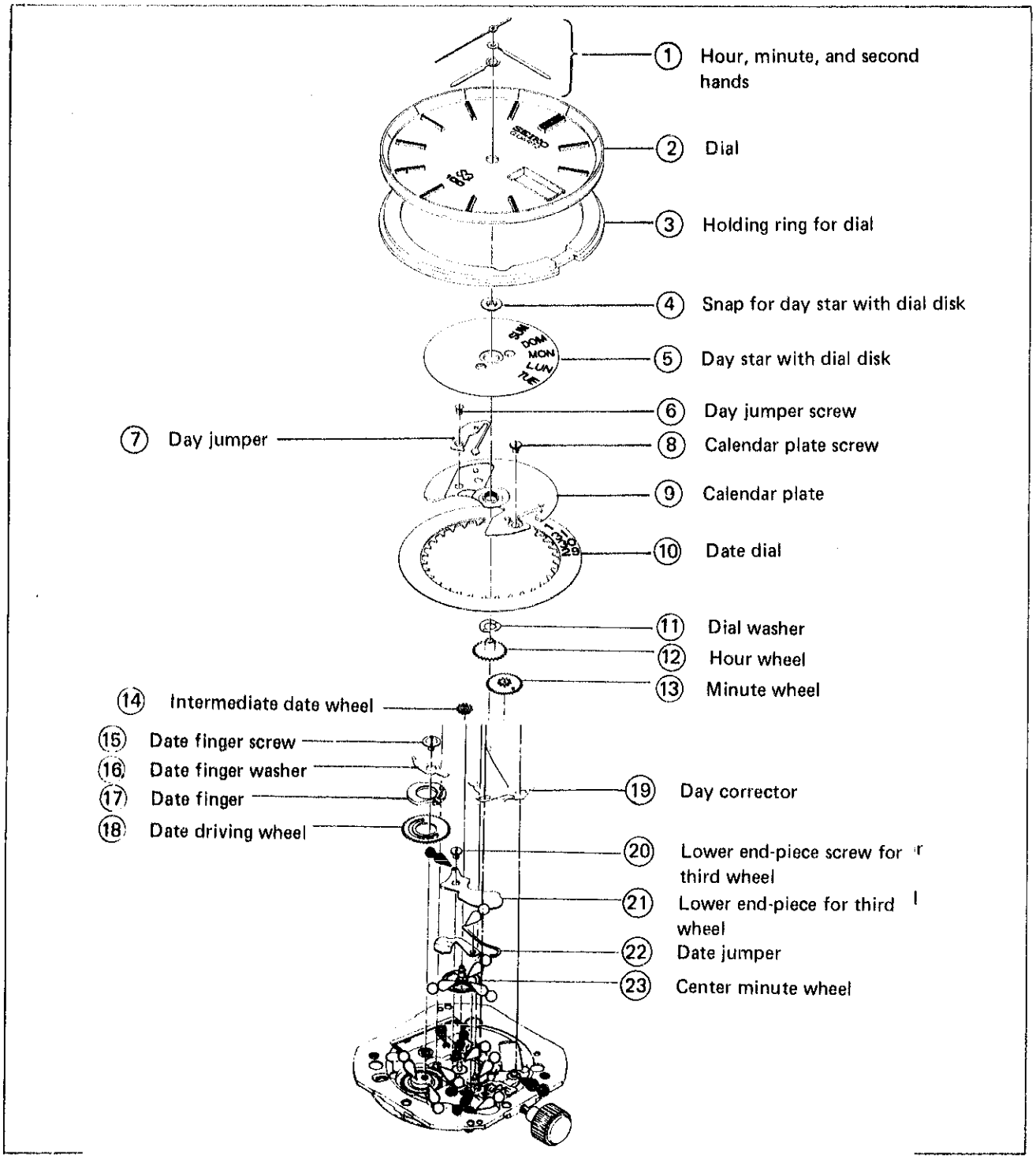

2. Coil block screw ~ crystal unit cushion

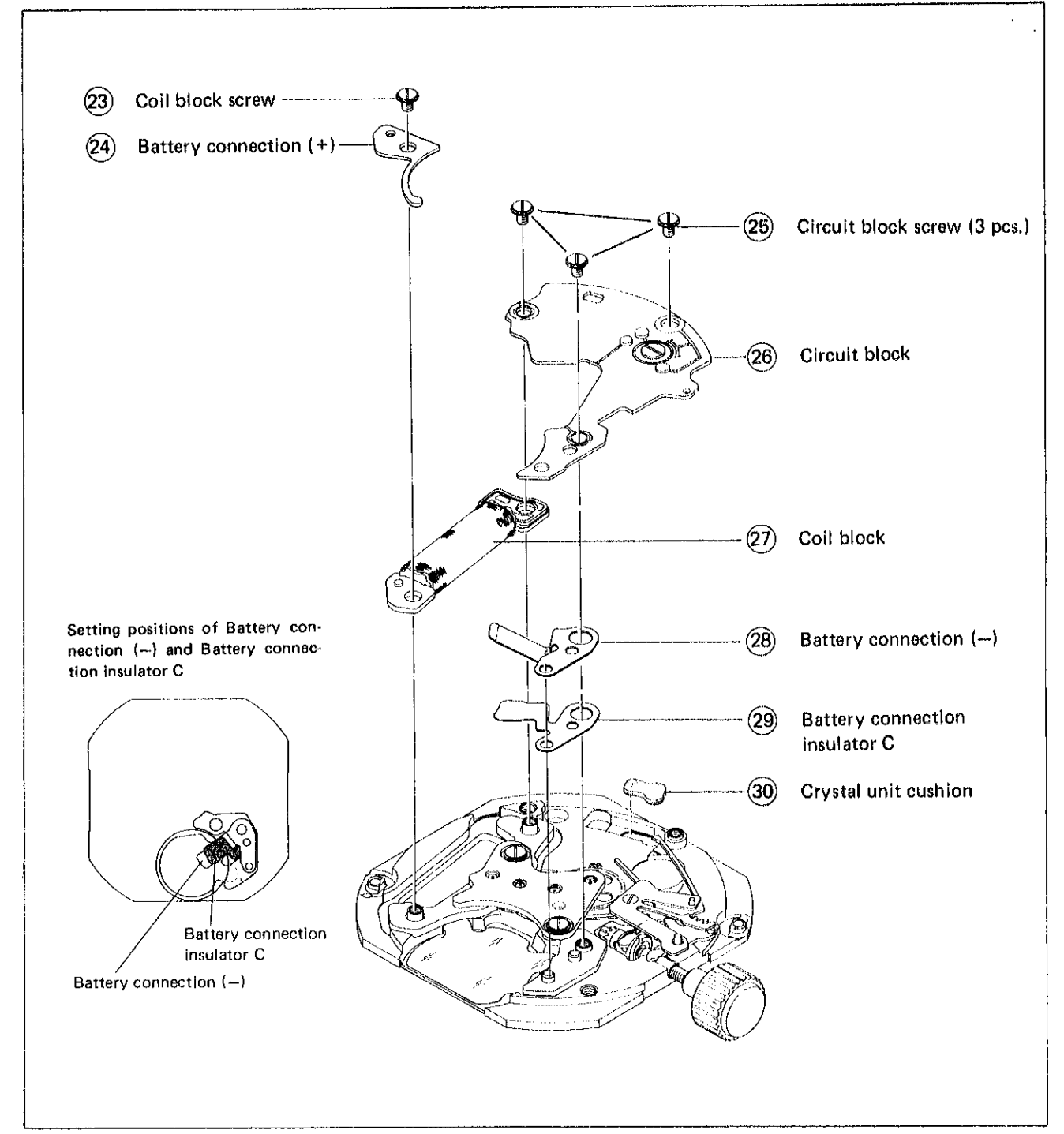

3. Train wheel bridge screw ~ clutch wheel

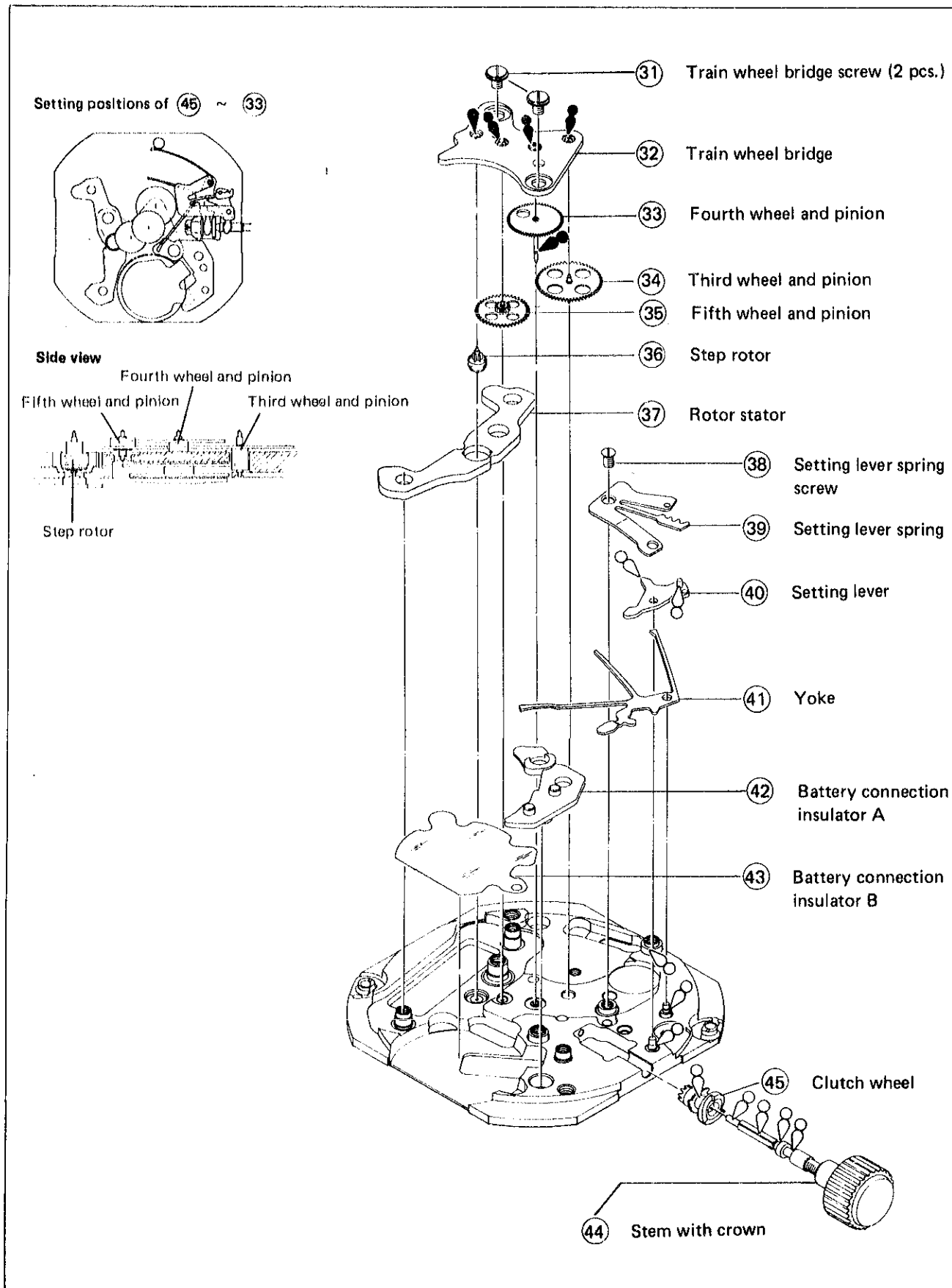

IV. CHECKING AND ADJUSTMENT

- The explanation here is particularly for the points of Cal. 6922A and 6923A.
Refer to the "TECHNICAL GUIDE, GENERAL INSTRUCTION" for SEIKO Analogue Quartz for details.

Procedure	
CHECK OUTPUT SIGNAL	
Use the electro-magnetic detection microphone. Any gate of the quartz tester is available.	Result: Normal : Input indicator blinks every second. Defective : Input indicator does not blink every second.
CHECK HAND SETTING CONDITION	
CHECK BATTERY VOLTAGE	
Set up the volt-ohm-meter. Range to be used: DC 3V	Result: Normal : More than 1.5V Defective : Less than 1.5V Replace the battery with a new one.
CHECK BATTERY CONDUCTIVITY	
CHECK CIRCUIT BLOCK CONDUCTIVITY	
CHECK COIL BLOCK	
Set up the volt-ohm-meter, and be sure to make a zero-ohm adjustment. Range to be used: OHMS x 100	Result: Normal : 2.7KΩ ~ 3.7KΩ Less than 2.7KΩ Defective (Short circuit) More than 3.7KΩ (Broken wire) Replace the coil block with a new one.
CHECK GEAR TRAIN MECHANISM	
CHECK SETTING AND CALENDAR MECHANISM	

Procedure

CHECK RESET AND TRAIN WHEEL SETTING CONDITIONS

1. Check the reset portion of the yoke.

- Crown at the normal and the first click positions

Reset portion Groove on the main plate

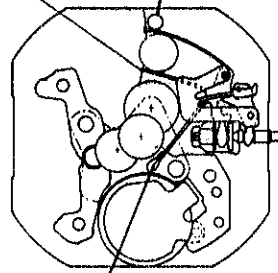

Inspection hole on the train wheel bridge

Result:

Normal : The reset portion is outside the groove.

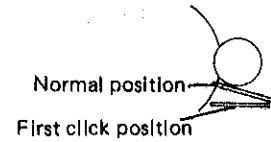

Defective : The reset portion is inside the groove.
Replace the yoke with a new one.

- Crown at the second click position

Normal : The reset portion is inside the groove.



Defective : The reset portion is outside the groove.
Replace the yoke with a new one.

2. Check the setting portion of the yoke.

- Crown at the normal and the first click positions

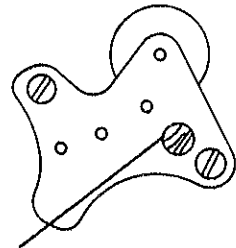

Inspection hole on the train wheel bridge

Result:

Normal : Clearance between the setting portion and the fourth wheel and pinion

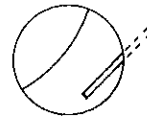

Defective : No clearance
Replace the yoke with a new one.

- Crown at the second click position

Normal : No clearance between the setting portion and the fourth wheel and pinion

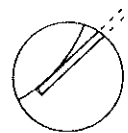

Defective : Clearance
Replace the yoke with a new one.

Procedure

3. After reassembling, check to see if the second hand stops promptly when the crown is pulled out to the second click position and if it starts promptly one second after the crown is pushed in back to the first click or the normal position.

(Reset condition can also be confirmed by the procedure CHECK OUTPUT SIGNAL.)
Crown at the second click position: Does not blink every second.
Crown at the first click or the normal position: Blinks every second.

CHECK ACCURACY

Use the electro-magnetic detection microphone.

CHECK CURRENT CONSUMPTION

Set up the volt-ohm-meter.
Range to be used: DC 12 μ A

Check current consumption for the whole of the movement.

Probe red Battery connection (-)
Probe black Battery (-) surface

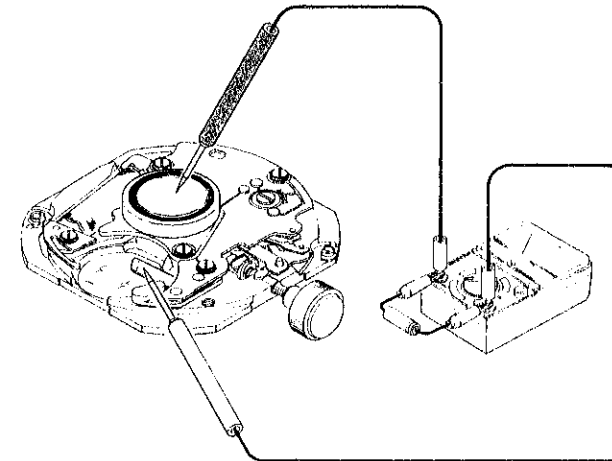

Result:

Normal : Less than 1.0 μ A
Defective : More than 1.0 μ A*

*How to find defects when the current consumption is more than 1.0 μ A:
Check current consumption of the circuit block alone.

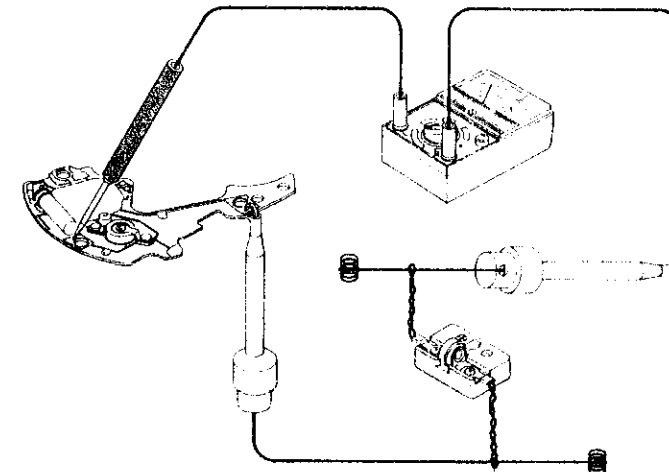

Result:

Normal : Less than 0.3 μ A
Check the gear train mechanism.
Defective : More than 0.3 μ A
Replace the circuit block with a new one.

Procedure

CHECK WATER RESISTANCE

CHECK BATTERY LIFE INDICATOR

Set up the MICRO TEST and select the output voltage within the range of $1.39 \pm 0.09V$.

CHECK APPEARANCE AND FUNCTIONING

All procedures of Disassembling, Reassembling, Lubricating, Checking and Adjustment are completed.