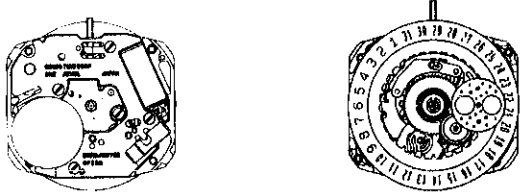

PARTS CATALOGUE/ TECHNICAL GUIDE

Cal. 6F22A

Cal. 6F29A

[SPECIFICATIONS]

Item		Cal. No.	6F22A	6F29A
		Movement		 <p>The illustrations refer to Cal. 6F22. (x 1.0)</p>
Movement size	Outside diameter	19.0 mm between 3 o'clock and 9 o'clock sides 22.0 mm between 6 o'clock and 12 o'clock sides		
	Casing diameter	φ24.0 mm		
	Height	3.3 mm		
Time indication		3 hands	2 hands	
Driving system		Step motor (Load compensated driving pulse type)		
Additional mechanism		<ul style="list-style-type: none"> • Numerical date calendar • Moon phase display • Instant moon phase setting device • Instant calendar (date) setting device • Train wheel setting device • Electronic circuit reset switch 		
Loss/gain		Monthly rate at normal temperature range: less than 15 seconds		
Regulation system		Nil		
Measuring gate by quartz tester		Use 10-second gate.		
Battery		SEIKO SR920SW, Maxell SR920SW, SONY SR920SW, Matsushita SR920SW, EVEREADY 371 Battery life is approximately 3 years. Voltage: 1.55V		
Jewels		1 jewel		

HATTORI SEIKO CO., LTD.

PARTS CATALOGUE

Cal. 6F22A, 6F29A

Disassembling procedures Figs.: ① → ④⑩

Reassembling procedures Figs.: ④⑩ → ①

Lubricating: Types of oil

● Moebius A

○ SEIKO Watch Oil S-6

Oil quantity

○ Normal quantity

○ Extremely small

Ex.: Cal. 6F22A

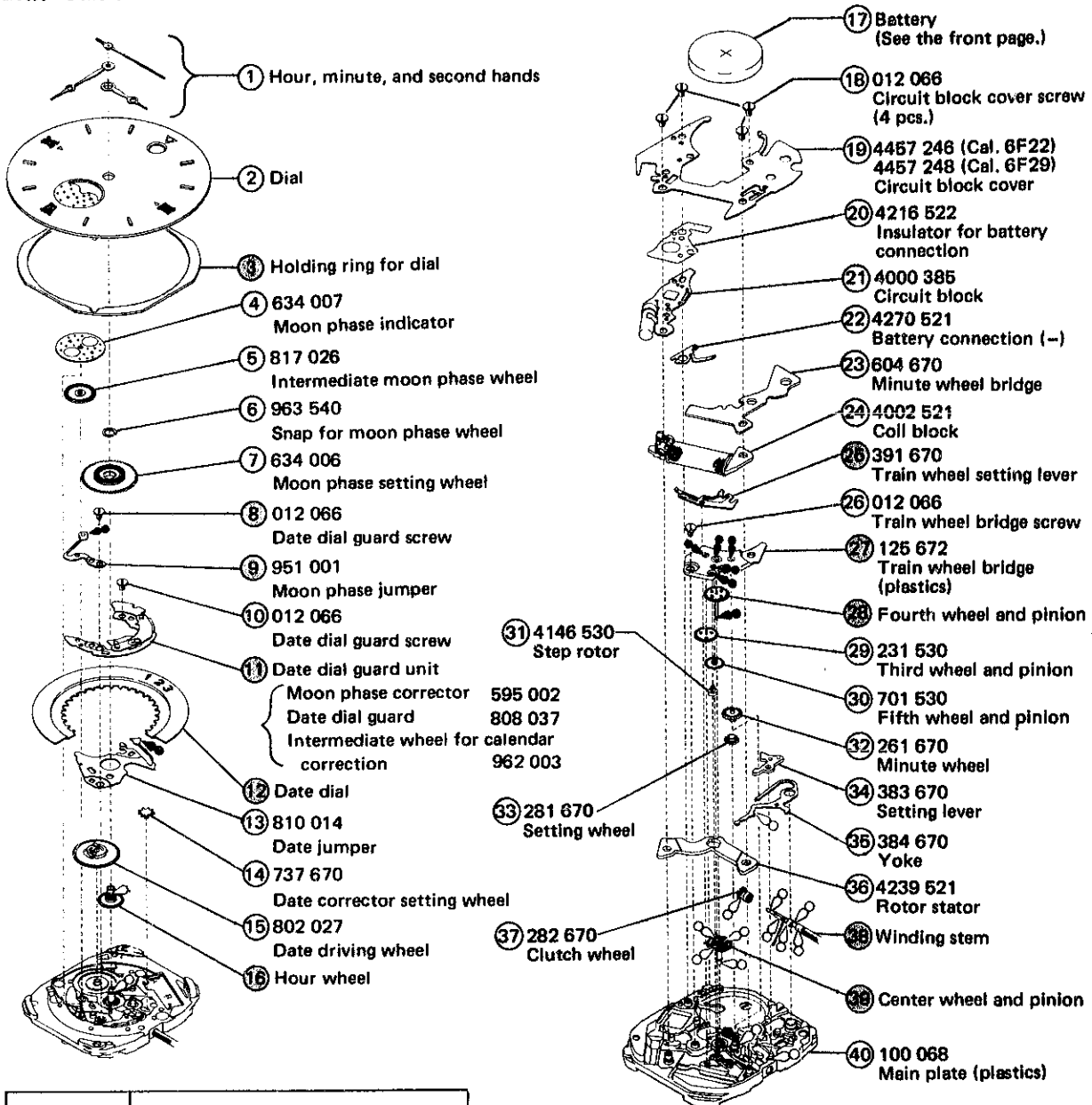

012 066
Date dial guard screw (2 pcs.)
Circuit block cover screw (4 pcs.)
Train wheel bridge screw (1 pc.)

⊙ ⇨ Please see the remarks on the following pages.

PARTS CATALOGUE

Cal. 6F22A, 6F29A

Remarks:

③ Holding ring for dial 884 158

The type of holding ring for dial is determined based on the design of cases.

Check the case number and refer to "SEIKO Casing Parts Catalogue" to choose a corresponding holding ring for dial.

⑫ Date dial



Part code	Crown position	Calendar frame position	Figure color	Ground color
801 431	3 o'clock	3 o'clock	Black	White
801 435	3 o'clock	12 o'clock	Black	White
801 437	3 o'clock	12 o'clock	Black	Gold
801 438	3 o'clock	12 o'clock	Gold	Black

The type of date dial differs, depending on the design of cases. When ordering the date dial, please specify (1) Cal. No., (2) the crown position, (3) the calendar frame position, (4) Dial No., and (5) the color.

⑯ Hour wheel

⑳ Fourth wheel and pinion

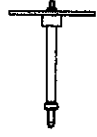
㉑ Center wheel and pinion

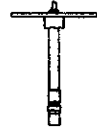
Part name	Center wheel and pinion	Fourth wheel and pinion	Hour wheel
Movement type M (Standard type)	 221 670	 241 670 (Cal. 6F22)	 271 179
		 241 179 (Cal. 6F29)	

The types of hour wheel, fourth wheel and pinion, and center wheel and pinion are determined based on the design of cases.

Check the case number and refer to "SEIKO Casing Parts Catalogue" to choose corresponding types.

⑳ Winding stem 351 670

The type of winding stem is determined based on the design of cases.

Check the case number and refer to "SEIKO Casing Parts Catalogue" to choose a corresponding winding stem.

- The explanation here is only for the particular points of Cal. 6F22A and 6F29A.
- For repairing, checking and measuring procedures, refer to the "TECHNICAL GUIDE, GENERAL INSTRUCTIONS".

I. STRUCTURE OF THE CIRCUIT BLOCK

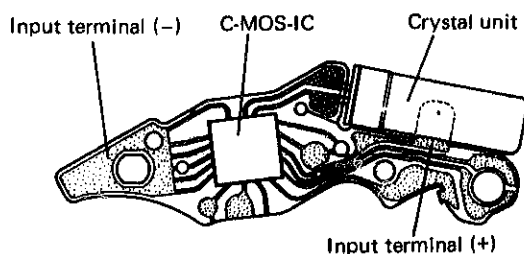

II. REMARKS ON DISASSEMBLING AND REASSEMBLING

Use the universal movement holder for disassembling and reassembling.

- ⑧ Date dial guard screw
- ⑨ Moon phase jumper

• How to install

Set the moon phase jumper to the moon phase jumper positioning pin, then tighten the date dial guard screw while holding the moon phase jumper lightly with fingers.

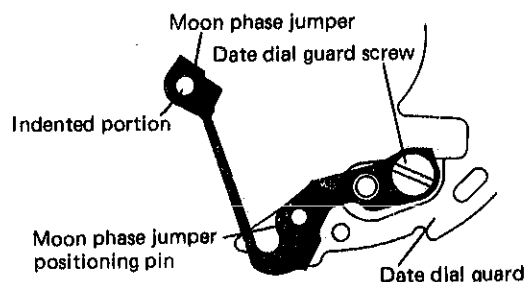

- ⑪ Date dial guard unit

* Unless necessary, do not disassemble the moon phase corrector and intermediate wheel for calendar correction from the date dial guard.

• How to disassemble

Place the date dial guard unit on a flat metal plate with the moon phase corrector side up, escaping the intermediate wheel for calendar correction.

Then, lightly press the axle head of the intermediate wheel for calendar correction with tweezers.

• Remarks on disassembling and reassembling the moon phase corrector

The moon phase corrector is a plastic part with some elasticity in the contact with the intermediate wheel for calendar correction. When disassembling and reassembling it, be careful not to scratch, deform, or warp it and also do not mistake the front for the back and vice versa.

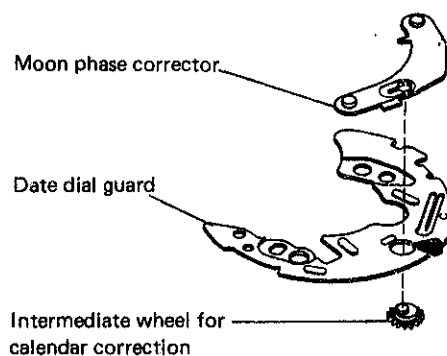

• Lubricating the intermediate wheel for calendar correction

Apply Moebius A to the contacting portion of the intermediate wheel for calendar correction with the date dial guard.

②⑤ Train wheel setting lever

● Setting position and lubricating

Set the yoke and the train wheel setting lever in position. Lubricate the contacting portion of the yoke and the setting lever.

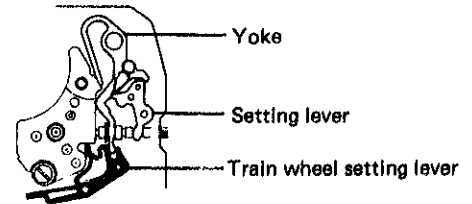

②⑦ Train wheel bridge

● Setting position

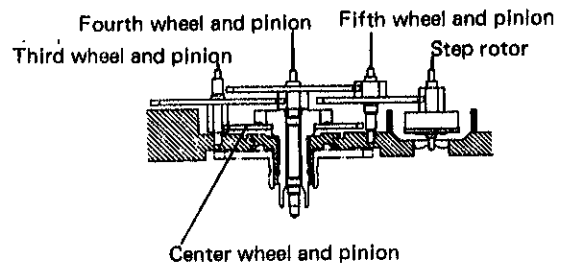
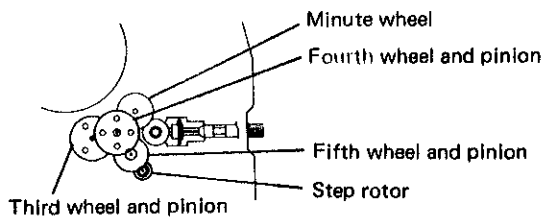

III. VALUE CHECKING

● Coil block resistance

2.7K Ω ~ 3.5K Ω

● Current consumption

For the whole of the movement: less than 1.2 μ A

For the circuit block alone : less than 0.4 μ A

Remarks:

When the current consumption exceeds the standard value for the whole of the movement but is less than the standard value for the circuit block alone, overhaul and clean the movement parts and then measure current consumption for the whole of the movement again. The driving pulse generated to compensate a heavy load that may apply on the gear train, etc. is considered to cause excessive current consumption for the whole of the movement.