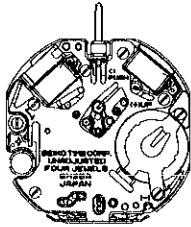
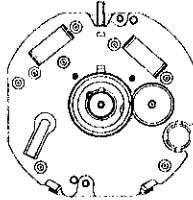

# PARTS CATALOGUE/ TECHNICAL GUIDE

## Cal. 8M25A

## Cal. 8M25B

### [SPECIFICATIONS]

		Cal. No.	8M25A	8M25B
<b>Item</b>				
<b>Movement</b>				
			(x 1.0)	
<b>Movement size</b>	Outside diameter		24.0mm between 6 o'clock and 12 o'clock sides 24.0mm between 3 o'clock and 9 o'clock sides	
	Casing diameter		φ25.5mm	
	Height		2.6mm	
<b>Time indication</b>			2 hands and mode indicator	
<b>Driving system</b>			Step motor (Fixed-width pulse system, 2 pcs.)	
<b>Additional mechanism</b>			<ul style="list-style-type: none"> <li>• Electronic circuit reset switch</li> <li>• Alarm (12-hour indication system)</li> <li>• Stopwatch (Up to 60 minutes in 1/5 seconds)</li> <li>• Countdown timer (Up to 60 minutes in seconds)</li> <li>• Hands 0-reset adjustment function</li> <li>• Alarm test system</li> <li>• Demonstration movement of the hands</li> </ul>	
<b>Loss/gain</b>			Monthly rate at normal temperature range: less than 15 seconds	
<b>Regulation system</b>			Trimmer condenser	
<b>Measuring gate by quartz tester</b>			Use 60-second gate.	
<b>Battery</b>			SEIKO SR920W, Maxell SR920W Battery life is approximately 2.5 years. Voltage: 1.55V	
<b>Jewels</b>			4 jewels	

## HATTORI SEIKO CO., LTD.

# PARTS CATALOGUE

Cal. 8M25A, 8M25B

Disassembling procedures Figs.: ① → ③⑧

Reassembling procedures Figs.: ③⑧ → ①

**Lubricating: Types of oil**

- ∞ Silicone oil 500,000 c.s.
- Moebius A
- ∞ SEIKO Watch Oil S-6

**Oil quantity**

- ∞ Normal quantity

**Note:**

Cal. 8M25A differs from Cal. 8M25B in ② mode indicator, ⑬ switch spring and ⑳ mode indicator arbor. However, disassembling and reassembling procedures are common to both calibres.

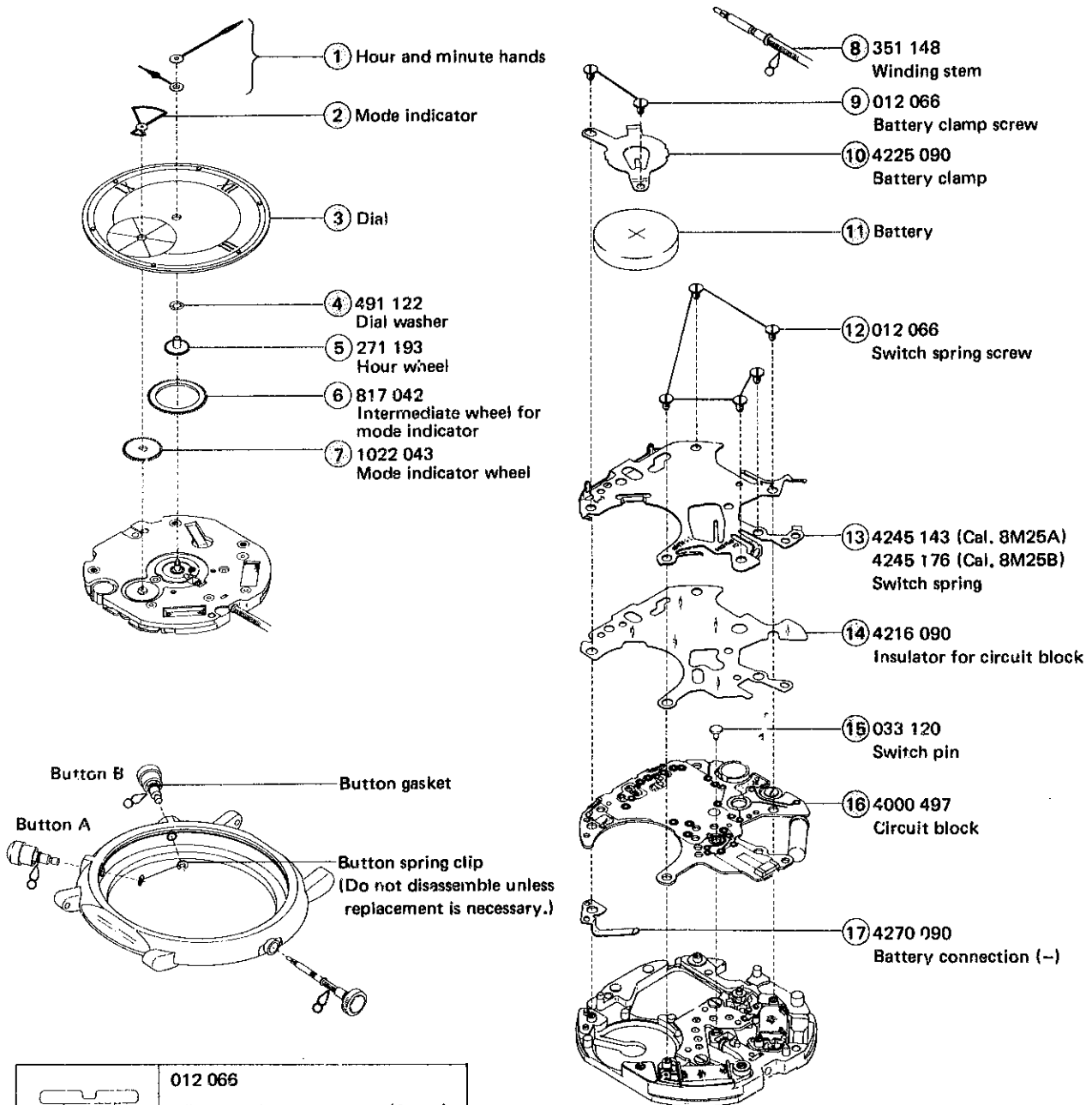

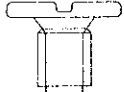
	012 066
	● Battery clamp screw (2 pcs.)
	● Switch spring screw (5 pcs.)
	● Train wheel bridge screw (2 pcs.)

○ → Please see the remarks on the following pages.

# PARTS CATALOGUE

Cal. 8M25A, 8M25B

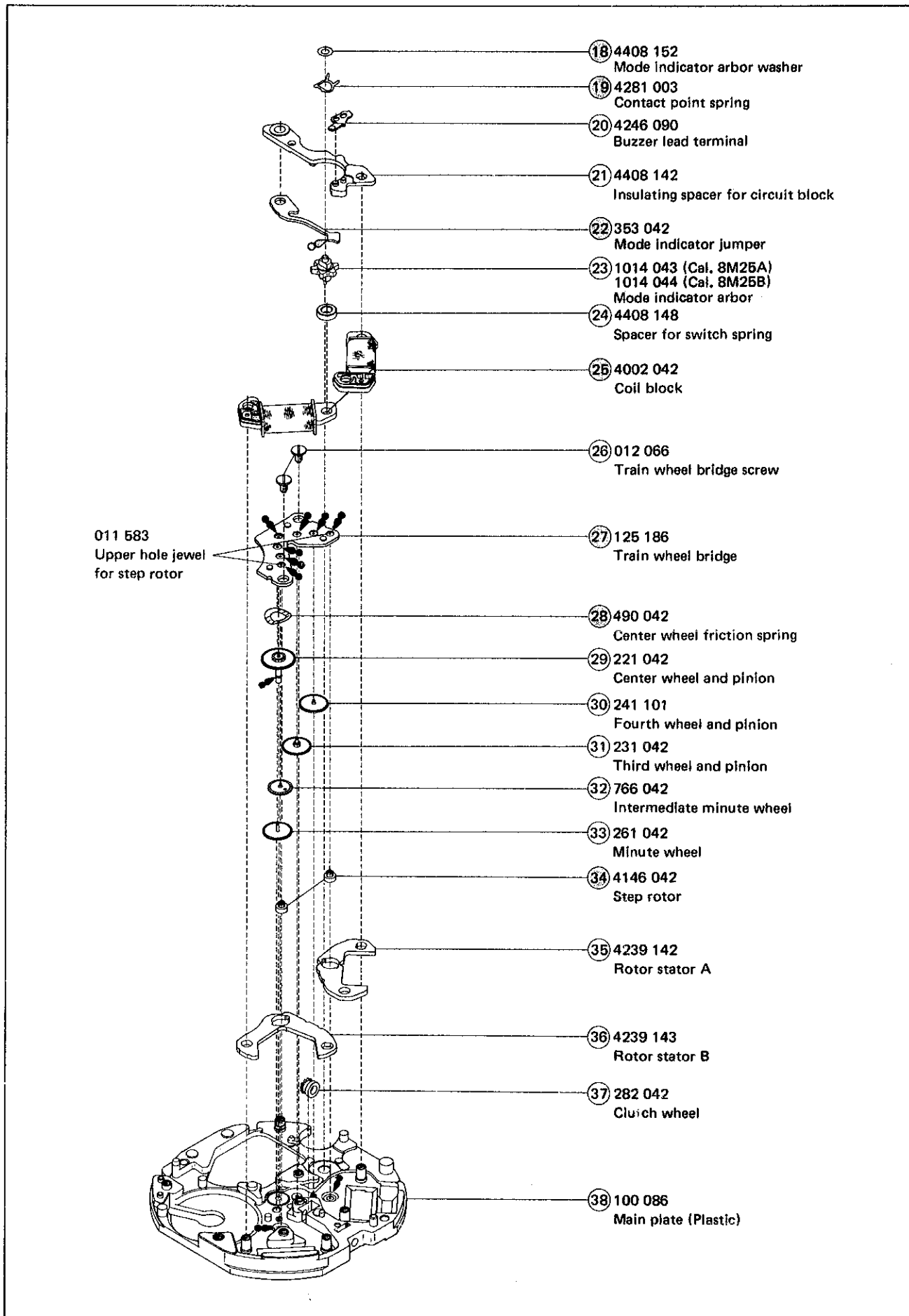

**Remarks:**

⑧ Winding stem 351 148

The type of winding stem is determined based on the design of case.

Check the case number and refer to "SEIKO Casing Parts Catalogue" to choose a corresponding winding stem.

⑱ Mode indicator arbor washer

The mode indicator arbor washer is used to adjust the looseness of the mode indicator arbor.

Therefore, the washer is not installed in the movement if the mode indicator arbor is securely fixed.

● Other parts

Piezoelectric element 4589 650

Earth lead terminal 4246 052 (For details, refer to the "IV. REMARKS ON EARTH LEAD TERMINAL" on pages 12 and 13.)

- The explanation here is only for the particular points of Cal. 8M25A and 8M25B.
- For the repairing, checking and measuring procedures, refer to the "TECHNICAL GUIDE, GENERAL INSTRUCTIONS".

## I. REMARKS ON REPAIRING Cal. 8M25A

- Cal. 8M25 is available in two types: Cal. 8M25A and Cal. 8M25B.  
The latter has an improved-type mode indicator.

### 1. After-sales servicing

Only the parts for Cal. 8M25B are available for supply. When replacing the mode indicator or mode indicator arbor of Cal. 8M25A with a new one, be sure to replace the mode indicator, mode indicator arbor and switch spring at the same time with those parts for Cal. 8M25B.

### 2. Difference between Cal. 8M25A and Cal. 8M25B

- How to distinguish the two calibres:  
See the calibre No. printed on the switch spring.
- Cal. 8M25A and Cal. 8M25B differ from each other in the following parts.

	Cal. 8M25A	Cal. 8M25B
Mode indicator	05SC 11HG 03SC 25NG	05SR 01AA 03SR 01NG
Mode indicator arbor	1014 043	1014 044
Switch spring	4245 143	4245 176

#### (1) Casing parts

- Mode indicator: Differ in diameter of the hole for mode indicator arbor.

(Ex.) Fan-shaped mode indicator

Cal. 8M25A

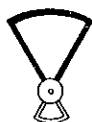

The hole diameter is equal to that of the second hand.

Cal. 8M25B



The hole diameter is equal to that of the minute hand.

#### (2) Movement parts

- Mode indicator arbor: Differ in diameter of the tip.

Cal. 8M25A

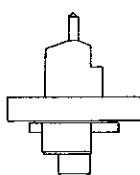

Cal. 8M25B

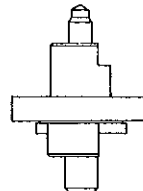

- Switch spring: Corresponding calibre No. is printed.

## II. STRUCTURE OF THE CIRCUIT BLOCK

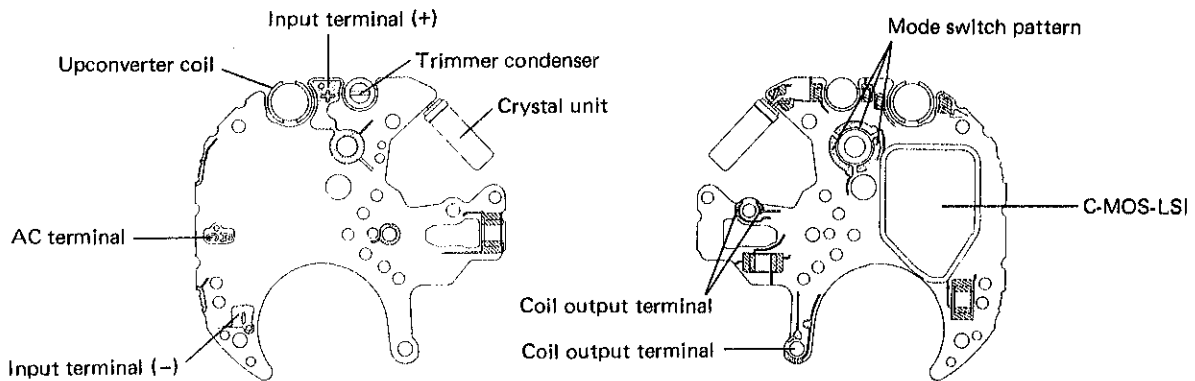

## III. REMARKS ON DISASSEMBLING AND REASSEMBLING

### ① Hands

Since a plastic main plate is used, place the movement on a flat metal plate or the like, and then install the hands at the 12 o'clock position.

In doing so, check that the buzzer lead terminal and the two protrusions of the switch spring are not pressed down as they protrude toward the case back side.

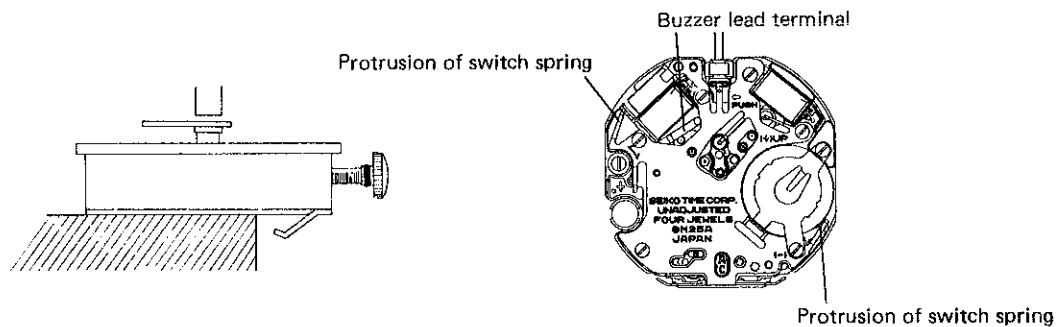

### ② Mode indicator

#### ● How to remove (Applicable to the fan-shaped mode indicator)

Set a hand-removing jig at the center of the mode indicator to remove it.

In doing so, check that the hand-removing jig is set right at the center of the mode indicator. Otherwise, the mode indicator may be deformed.

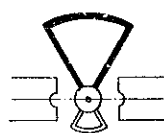

[Correct]

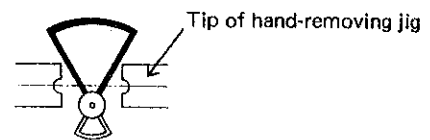

[Incorrect]

• **How to install**

Make sure that the mode indicator and the mode indicator arbor are set as shown below.

- (1) Turn the crown to set the notched portion of the mode indicator arbor at the 6 o'clock position.

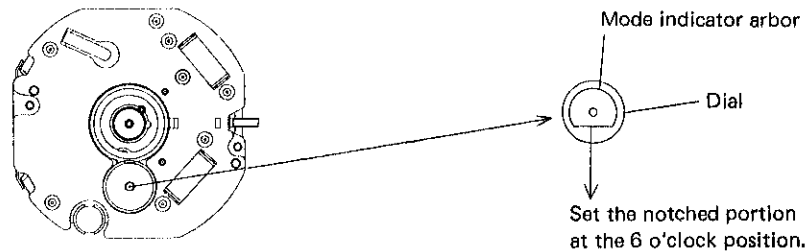

- (2) Install the mode indicator so that it points to "TIME".

Refer to the illustrations below, as the shape of the mode indicator and dial differ depending on the models.

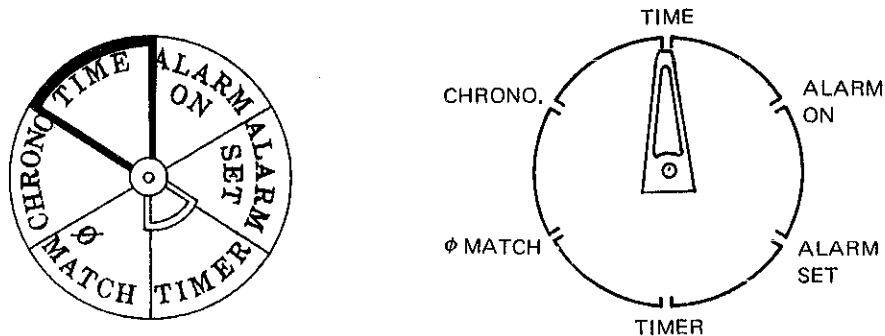

- (3) After installing the mode indicator, give it three full turns by turning the crown to check if it stops exactly at the respective mode positions.

If the mode indicator arbor is loose in the contact with the mode indicator's pipe, the mode indicator will stop out of the proper positions. In that case, slightly flatten the mode indicator's pipe at the part indicated in the illustration, and then install the mode indicator to the mode-indicator arbor again.

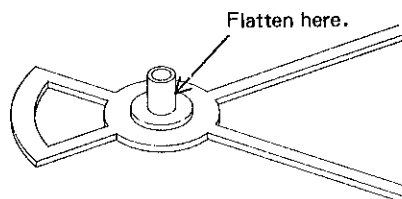

③ **Dial**

• **How to remove**

Pry up the dial at the two recessed parts indicated in the illustration using a screwdriver.

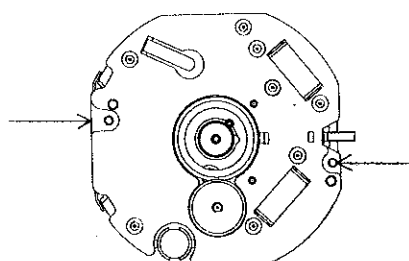

④ Dial washer

②⑧ Center wheel friction spring

• How to distinguish the two parts

[Dial washer]

[Center wheel friction spring]

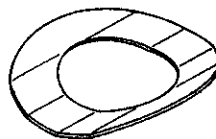
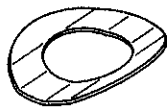

- Bent
- With the smaller diameter

- Bent
- With the larger diameter

⑦ Mode indicator wheel

• How to install

Set the mode indicator wheel to the mode indicator arbor so that it fits in with the notched part of the mode indicator arbor.

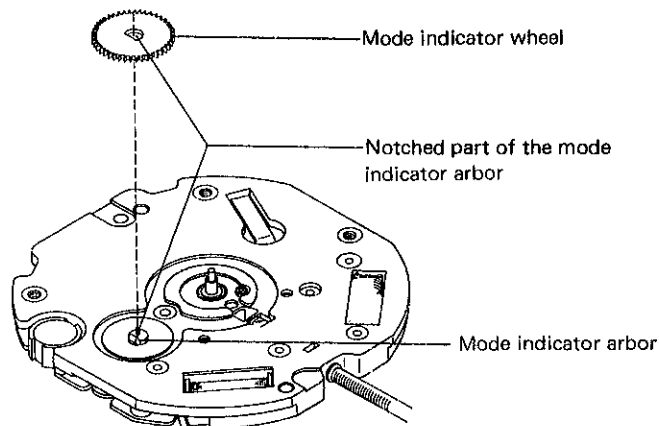

⑧ Winding stem

• How to remove

Remove the winding stem while pushing the indented portion of the switch spring (marked with " ← PUSH").

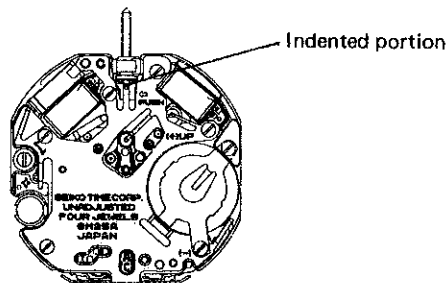



## ⑩ Battery clamp

### • How to install

Slip the tip of the battery clamp into a gap under the switch spring.

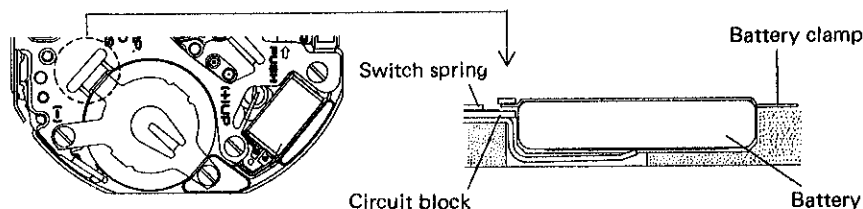

## ⑪ Battery

### • A necessary step after installing the battery

After the battery is replaced with a new one, or after the battery is removed and re-installed following the repairing procedures, be sure to short-circuit the AC terminal of the circuit block and the battery clamp twice with conductive tweezers to reset the circuit. (When checking the current consumption, short-circuit with the power supplied from external source.)

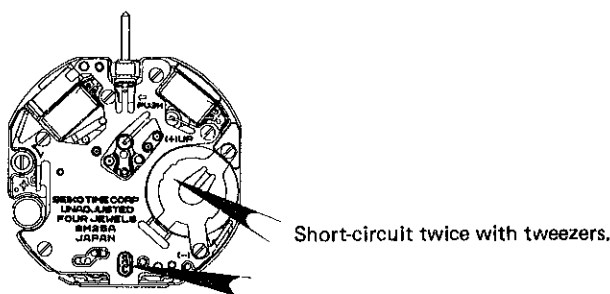

\* The circuit can be reset with a complete watch. Follow the procedure below.

- [1] Turn the crown to set the mode indicator to "φ MATCH".
- [2] Pull out the crown to the first click.
- [3] Keep buttons "A" and "B" pressed at the same time for approximately 3 seconds.  
When the buttons are released, a beep sounds and the hour and minute hands start moving counterclockwise and clockwise, respectively.
- [4] Press button "A" or "B" once to stop the hands.
- [5] Press button "A" and "B" repeatedly but separately to reset the minute and hour hands respectively to the "0" position (12 o'clock position).
- [6] Turn the crown to set the mode indicator to "TIME". Then, pull out the crown to the first click, and press button "A" and "B" repeatedly but separately to set the minute and hour hands respectively to the desired time.

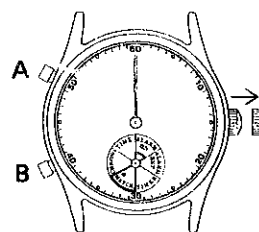

**⑭ Insulator for circuit block**

The insulator for circuit block is colorless and transparent. Therefore, make sure that it is installed without fail.

**⑮ Switch pin**

If failure of time setting or hands 0-reset adjustment function occurs with the crown at the first click, check if proper clearance is provided between the switch pin and circuit block.

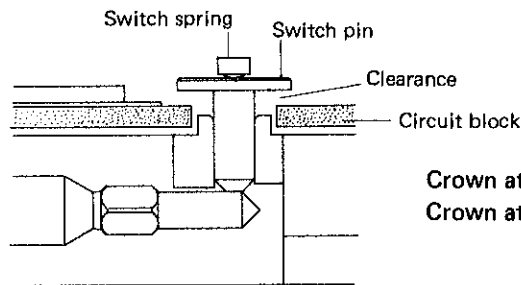

Crown at the normal position: Clearance provided.  
 Crown at the first click : No clearance provided.

**⑯ Circuit block**

**⑰ Contact point spring**

If a malfunction occurs in any of the modes, check the following points.

[1] Check if the following parts are set as shown below.

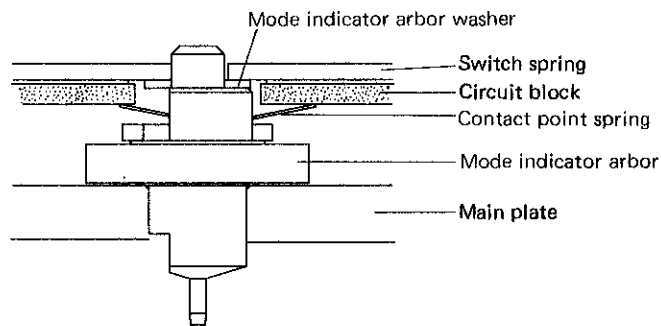

[2] Check if the contact point spring is deformed.

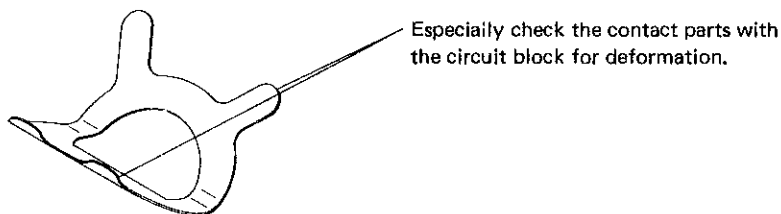

**⑱ Mode indicator arbor washer**

The mode indicator arbor washer is used to adjust the looseness of the mode indicator arbor. Therefore, the washer is not installed in the movement if the mode indicator arbor is securely fixed.

## 22 Mode indicator jumper

Take care not to deform the mode indicator jumper when disassembling or reassembling it, as extremely high pressure is applied to it.

### • How to remove

Release the tip of the mode indicator jumper from the mode indicator arbor, and then lift up "A" portion in the illustration.

### • How to install

Reverse the procedures for disassembling.

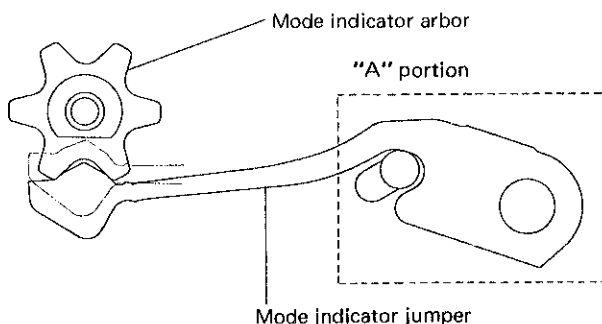

## 25 Coil block

Two coil blocks can be used interchangeably.

## 27 Train wheel bridge

## 28 Center wheel friction spring

## 34 Step rotor

### • Setting position of the train wheel

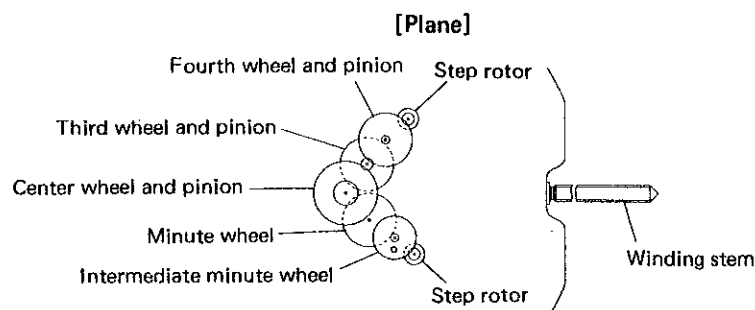
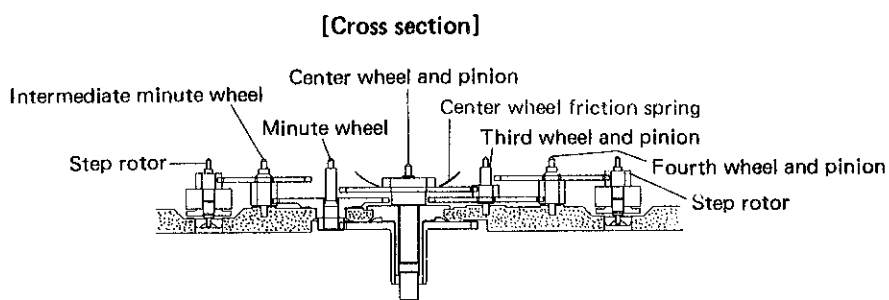

- Do not deform the center wheel friction spring, as this will cause the watch to stop or lose.
- Two step rotors can be used interchangeably.
- Distinction of wheels

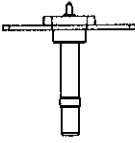
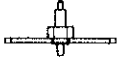
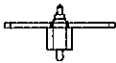
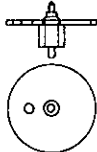
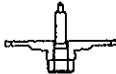
Name	Center wheel and pinion	Third wheel and pinion	Fourth wheel and pinion	Intermediate minute wheel	Minute wheel
Shape					
Distinctive feature	Tall in height	Short pinion	Long pinion	A hole on wheel	No pivot

## IV. REMARKS ON EARTH LEAD TERMINAL

- Some models are provided with an earth lead terminal, depending on the shape of the switch spring. If the switch spring includes an earth lead terminal portion as shown below, it is not necessary to install the earth lead terminal.

[Models with earth lead terminal]

Switch spring

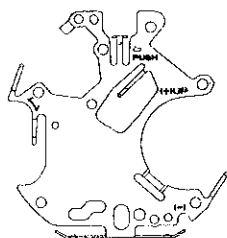

[Models without earth lead terminal]

Switch spring

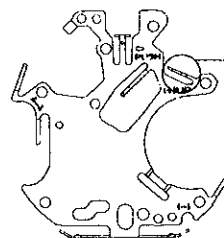

The earth lead terminal portion is included in the switch spring.

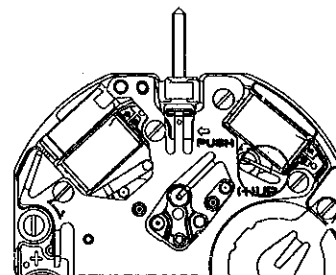
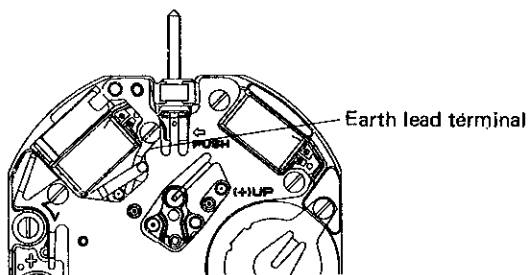

\* Even if the earth lead terminal is originally installed in a movement, it is not necessary to install one when the switch spring is replaced with the one including an earth lead terminal portion.

- Setting position and parts supply of the earth lead terminal

## 1. Setting position

- Make sure that the tip of the earth lead terminal securely contacts with the train wheel bridge.
- When tightening the switch spring screw, take care not to move the earth lead terminal out of position and not to cut the coil.
- Check that the earth lead terminal does not touch the buzzer lead terminal.

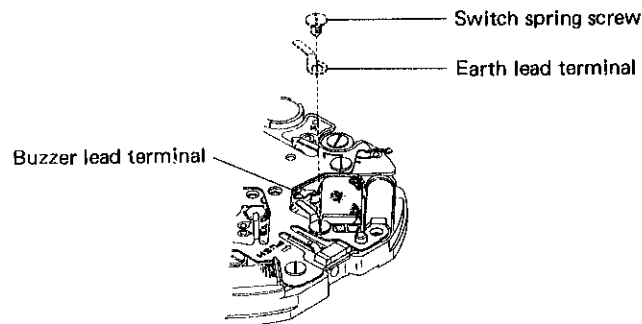

## 2. Parts supply

When ordering the earth lead terminal, please specify the following parts code No.

Earth lead terminal: 4246 052

## V. VALUE CHECKING

- Coil block resistance  
 $1.2K\Omega \sim 1.6K\Omega$
- Upconverter coil resistance  
 $120\Omega \sim 180\Omega$
- Measuring time accuracy

Turn the crown to set the mode indicator to "TIME" or "ALARM ON".

Since the minute hand moves at 12-second intervals, use 60-second gate of the quartz tester to measure accuracy.

\*Time accuracy can also be measured with the mode indicator set at "TIMER" or "CHRONO". In this case, any gate of the quartz tester can be used to measure the daily rate.

- Current consumption

For the whole of the movement: less than  $2.5\mu A$   
For the circuit block alone : less than  $1.6\mu A$

**Note:**

Before measuring current consumption, it is necessary to reset the circuit with the power supplied from an external source. Therefore, follow the procedures below to measure the current consumption.

- Measure the current consumption for the whole of the movement.  
(Make sure that the battery clamp screw is securely tightened.)
  - [1] Install the dial and mode indicator, and turn the crown to set the mode indicator to "TIME" or "ALARM ON".
  - [2] Short-circuit the "AC" pattern of the circuit block and the switch spring twice to reset the circuit.
  - [3] Press button "A" or "B" once.
  - [4] The minute hand start moving at 12-second intervals. Read the maximum value of the current consumption, and calculate the current consumption per second.  
Note that measurement obtained while the hands are not moving corresponds to the current consumption for the circuit block alone.  
(For details, refer to Chapter 5 "MEASUREMENT" of the "TECHNICAL GUIDE, GENERAL INSTRUCTIONS".)