

Catalog No. E81-1 ~ E81-2
カタログ番号 E81-1 ~ E81-2

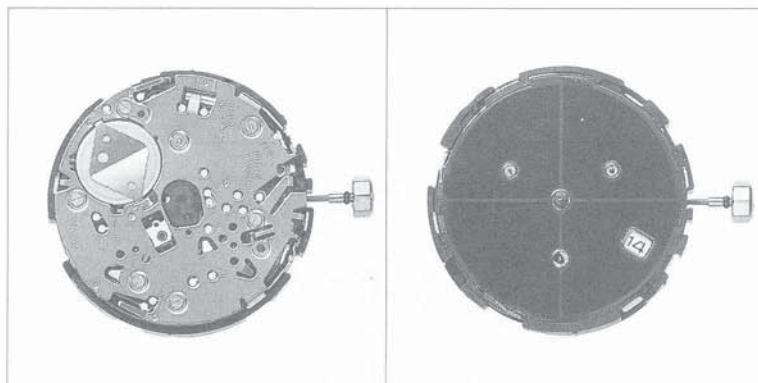

Caliber No. E810
キャリバー No. E810

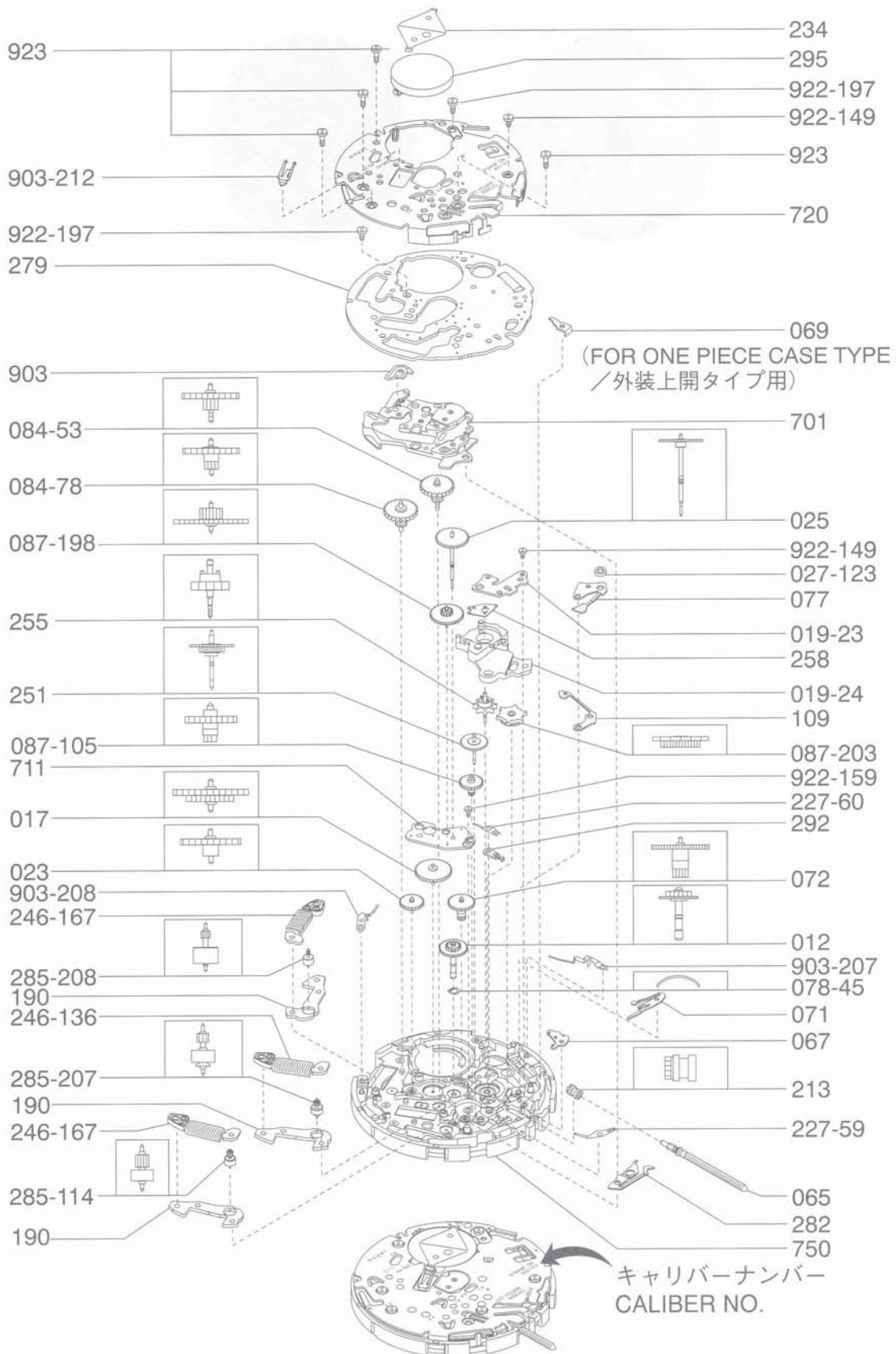

Catalog No. E81-1
カタログ番号 E81-1

Part No. 部品番号	キャリバーNo.		Caliber No. No. of jewels	E810M						
	部品名称	石数								
701	輪列受		Train wheel bridge	E52						
012	二番車		Center wheel	236						
017	三番車		Third wheel and pinion	158						
019	スイッチレバー押工		Switch lever holder	23						
019	躍制レバー押工		Date jumper holder	24						
023	四番車		Fourth wheel and pinion	346						
025	秒車		Second wheel	111						
027	裏押工座		Setting lever spring spacer	123						
065	巻真		Setting stem	522						
067	オシドリ		Setting lever	195						
071	カンヌキ		Yoke	142						
072	日ノ裏車		Minute wheel and pinion	127						
077	裏押工		Setting lever spring	137						
078	針座 (1)		Dial washer (1)	45						
084	五番車		Fifth wheel and pinion	78						
084	クロノグラフ中間車		Intermediate recording wheel	53						
087	秒中間車		Intermediate for second wheel	198						
087	日回シ伝工車 (1)		Intermediate date wheel (1)	105						
087	モード中間車 (3)		Intermediate mode wheel (3)	203						
109	モード躍制レバー		Mode jumper	68						
190	完成ヨーク (1)		Stator (1)	103						
190	完成ヨーク (2)		Stator (2)	103						
190	完成ヨーク (3)		Stator (3)	103						
213	スイッチ車		Switching wheel	47						
227	スイッチバネ (1)		Switch spring (1)	59						
227	スイッチバネ (2)		Switch spring (2)	60						
234	二次電池押工		Secondary battery strap	819						
246	完成コイル (1)		Coil unit (1)	167						
246	完成コイル (2)		Coil unit (2)	136						
246	完成コイル (3)		Coil unit (3)	167						
251	クロノグラフ車		Chronograph hammer	21						
255	モード車		Mode wheel	47						
258	モード切換スイッチバネ		Mode switch spring	34						
279	複合回路		Unit of electronic circuit	C46						
282	スイッチレバー戻シバネ		Switch lever actuating spring	93						
285	完成ローター (1)		Rotor (1)	208						
285	完成ローター (2)		Rotor (2)	207						
285	完成ローター (3)		Rotor (3)	113						
292	スイッチレバー		Switch lever	34						
295	二次電池		Secondary battery	40						

Part No. 部品番号	キャリバーNo.	Name of parts	Caliber No.	E810M						
	石数		No. of jewels							
部品名称				00						
711		Center wheel cock		194						
720		Circuit unit supporter		480						
750		Plate complete		C90						
903		Contact spring for solar cell (1)		207						
903		Contact spring for solar cell (2)		208						
903		Contact spring		212						
903		Minus lead plate		206						
922		Switch lever screw		149						
922		Center wheel cock screw		159						
922		Electronic circuit screw		197						
922		Circuit unit supporter screw (2)		149						
922		Circuit unit supporter screw (3)		197						
923		Circuit unit supporter screw (1)		86						

Catalog No. E81-2
 カタログ番号 E81-2

