

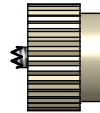

**SELLITA**  
Le temps en mouvement

# SW 220-1

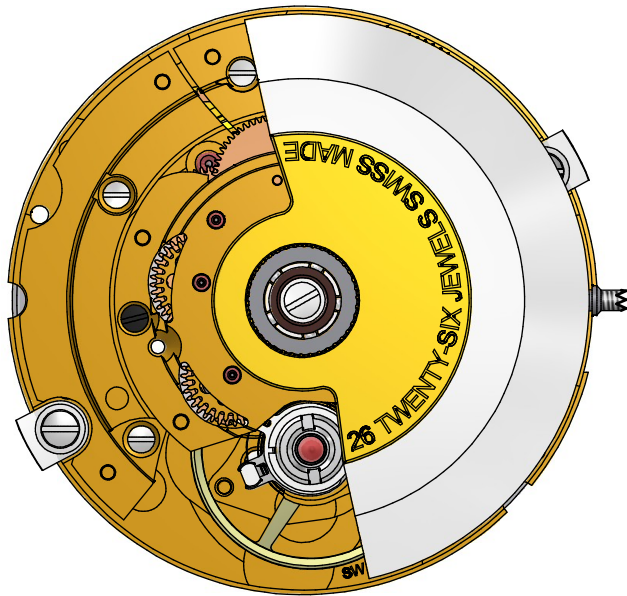

**11½" SW 220-1**  
**Automatique**  
**Swiss made**

## SPECIFICATIONS TECHNIQUES

- Hauteur 5,05 mm
- Ø d'encageage 25,60 mm
- 28800 alt/h (4Hz)

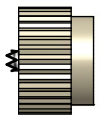
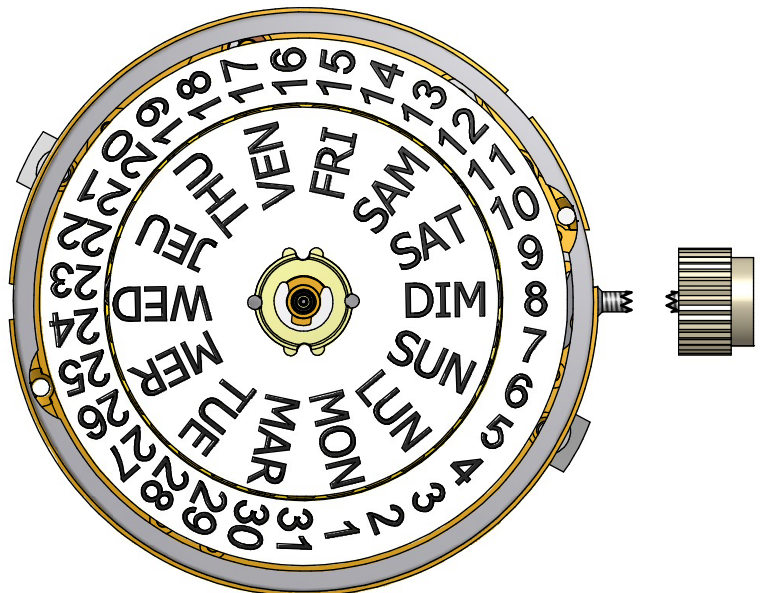

**SELLITA WATCH CO SA**  
Crêt du Locle 11  
CH-2300 La Chaux-de-fonds

☎ 032.967.99.67  
☎ 032.967.99.60  
www.sellita.ch  
✉ info@sellita.ch





  
**SELLITA**  
Le temps en mouvement

09.06.09

## Montage du mécanisme

407	5445		
410			
401			
2570			
443			
435			
445			

## Lubrification :

<b>Moebius 9010</b> Huile fluide	
<b>Moebius HP 1300</b> Huile visqueuse	
<b>Moebius HP 1300</b> Huile visqueuse, faible quantité	
<b>Moebius 941 ou 9415</b> Huile spéciale pour levées	
<b>Moebius 9501</b> Graisse	

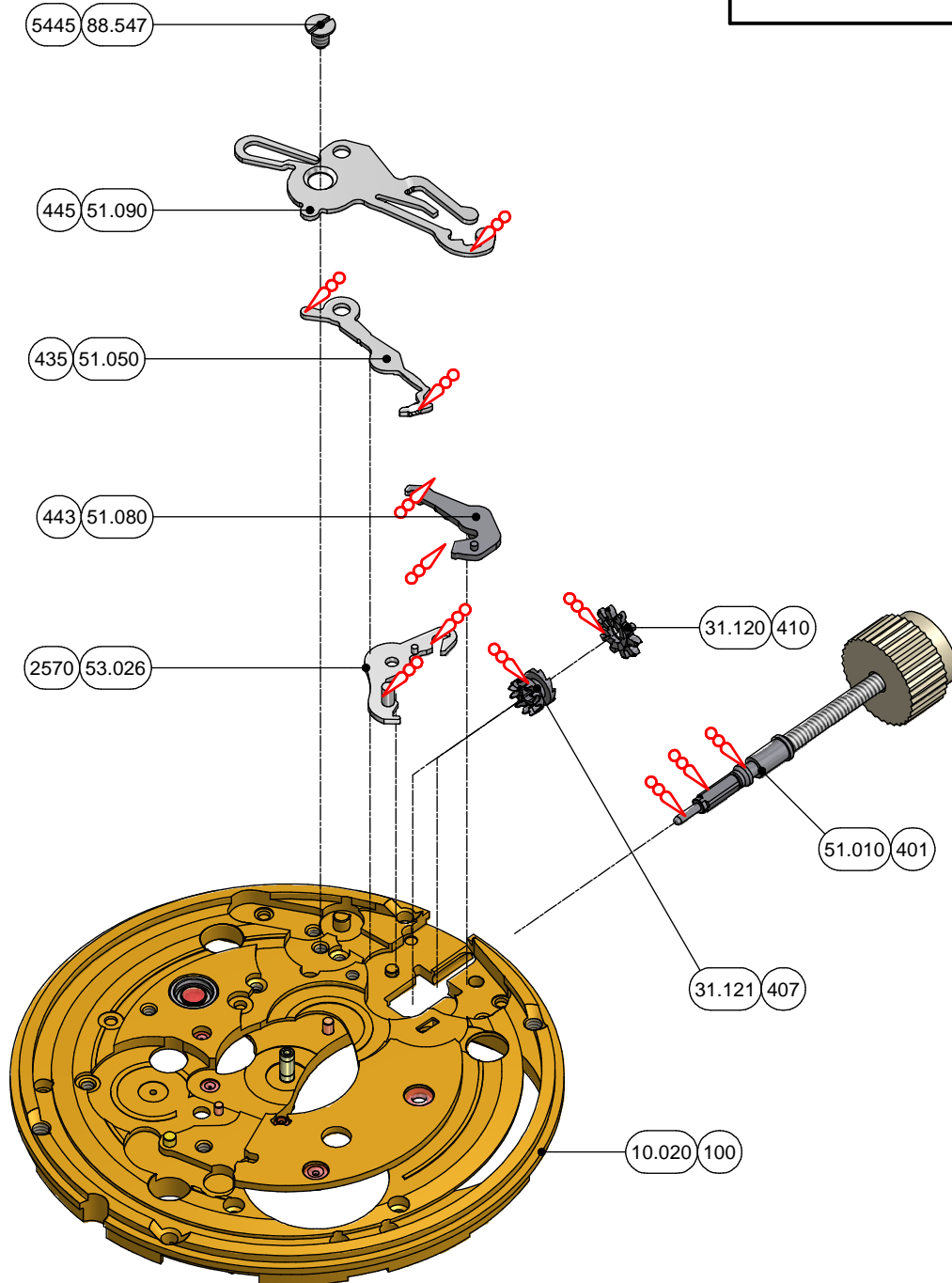





# Calibre SW220-1 (11½")

# Mouvement de base

### Montage du mouvement de base

9433	420	110	303/3
201/1	5420	5110	303/2
180	415	710	721
105	5415	125	121
5105	210	5125	5121
430	705	358	
425	227	375/2	

### Lubrification :

- Moebius 9010**  
Huile fluide 
- Moebius HP 1300**  
Huile visqueuse 
- Moebius HP 1300**  
Huile visqueuse, faible quantité 
- Moebius 941 ou 9415**  
Huile spéciale pour levées 
- Moebius 9501**  
Graisse 

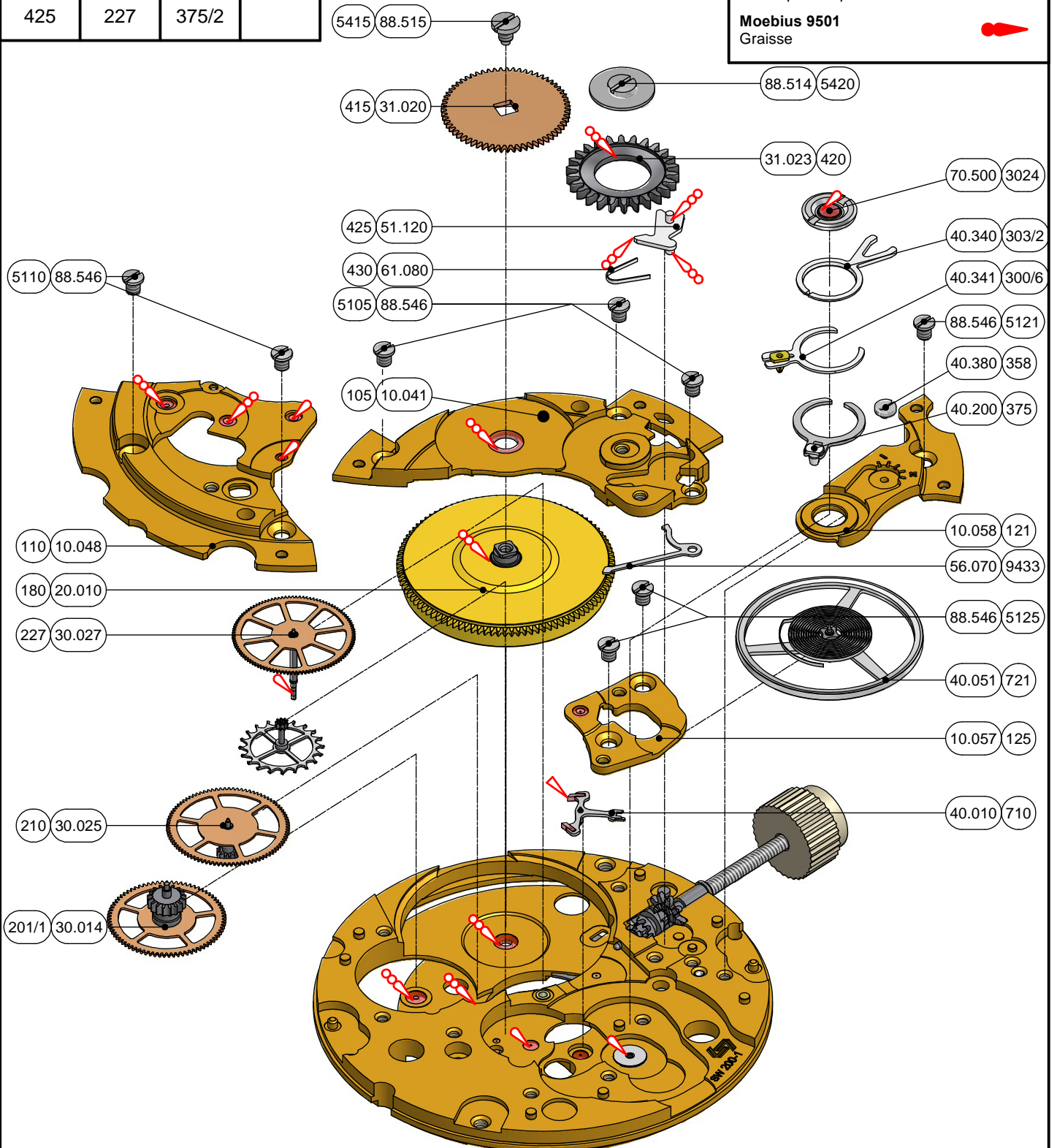

### Montage du dispositif automatique

1134	1497		
1530	1143		
1488	51497		
1482	51134		
1481			
1141			
51141			

### Lubrification :

#### Moebius 9010

Huile fluide



#### Moebius HP 1300

Huile visqueuse



#### Moebius HP 1300

Huile visqueuse, faible quantité



#### Moebius 941 ou 9415

Huile spéciale pour levées



#### Moebius 9501



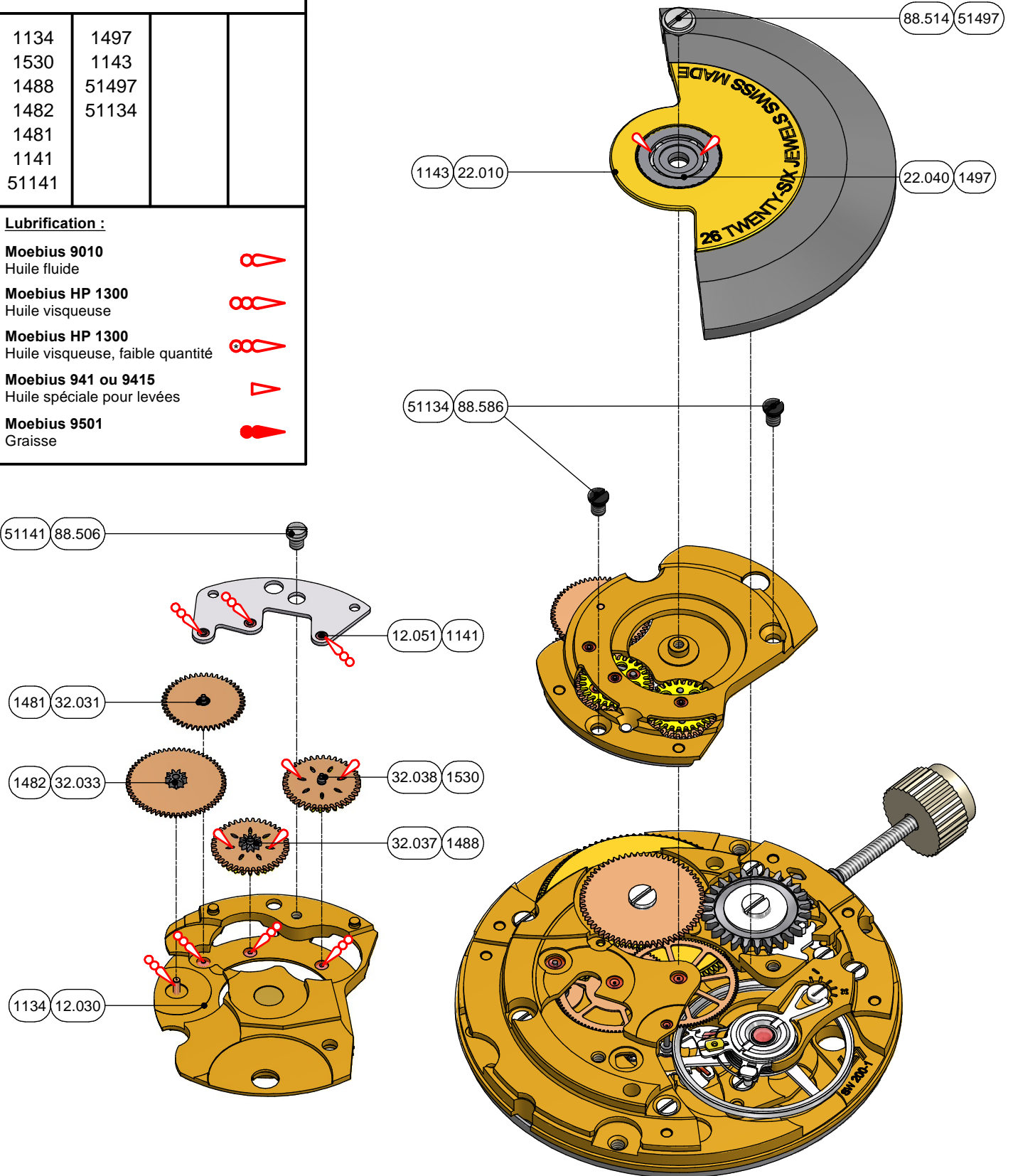

Graisse



### Montage du mécanisme du calendrier

450	462	2784
2569	5462	2595
2567	2633	52595
52567	2632	2557/1
242	2555	2561/1
260	2644	145
255	2543	2780

### Lubrification :

- Moebius 9010**  
Huile fluide 
- Moebius HP 1300**  
Huile visqueuse 
- Moebius HP 1300**  
Huile visqueuse, faible quantité 
- Moebius 941 ou 9415**  
Huile spéciale pour levées 
- Moebius 9501**  
Graisse 

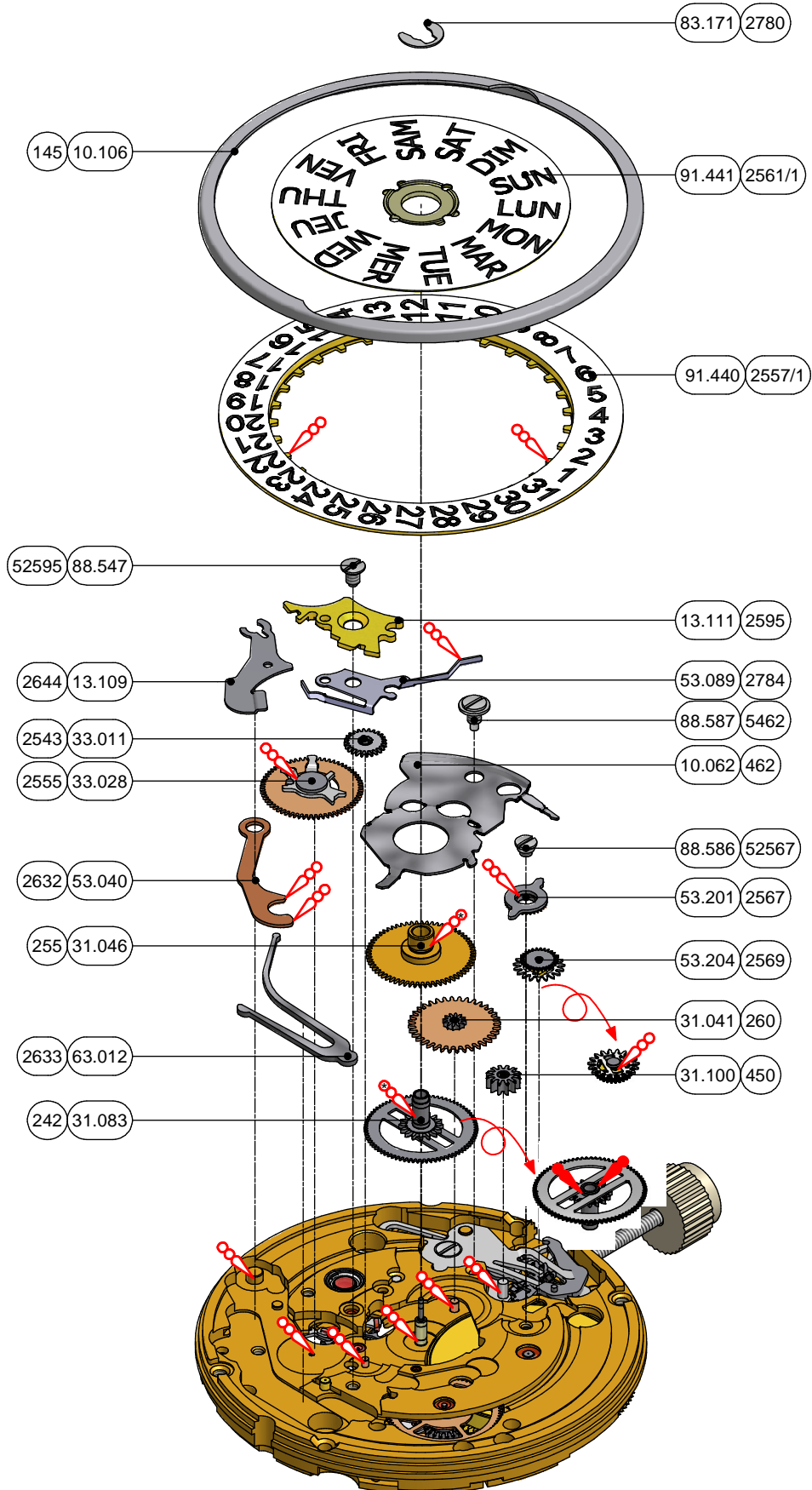

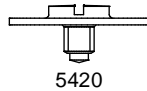
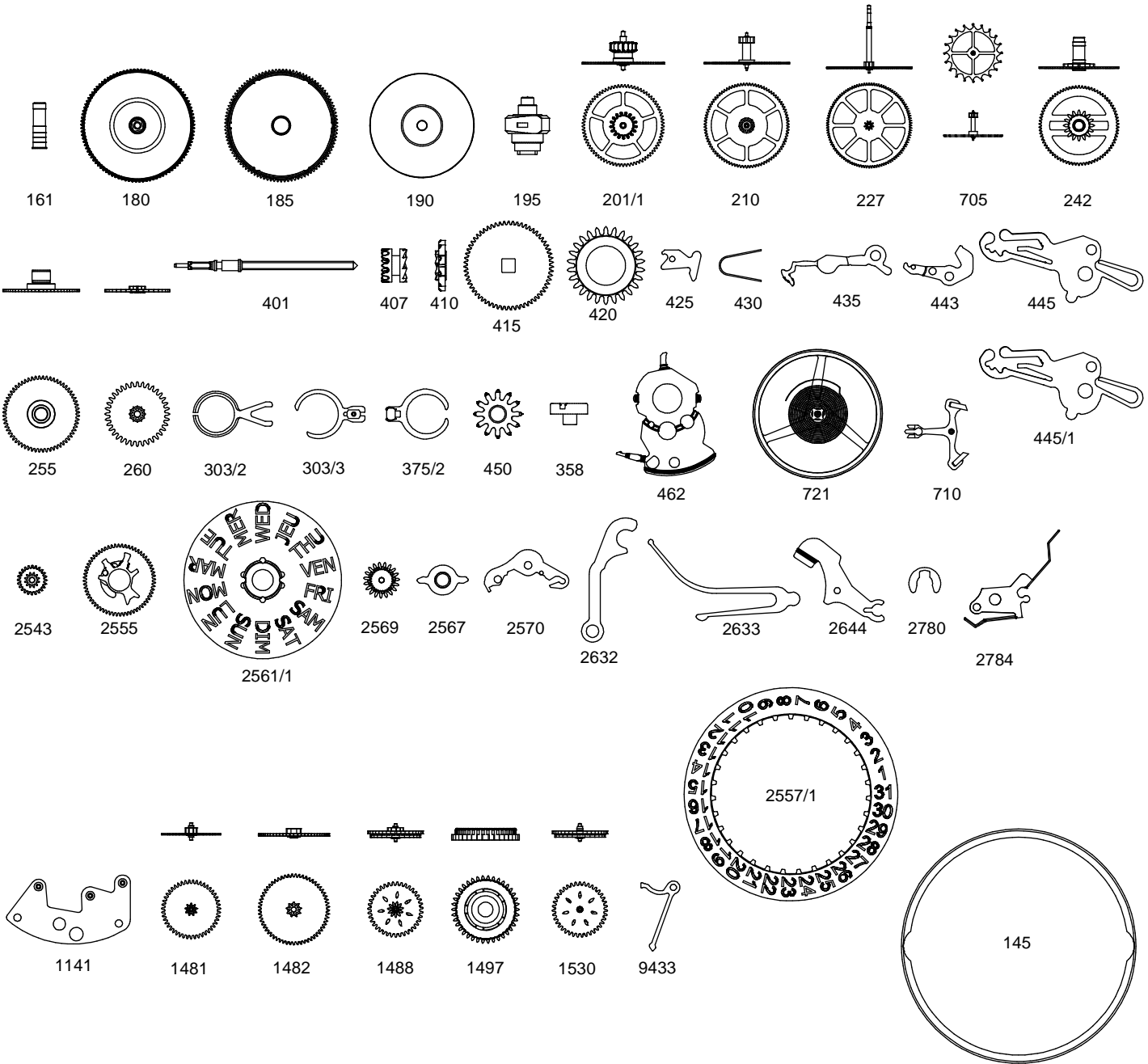
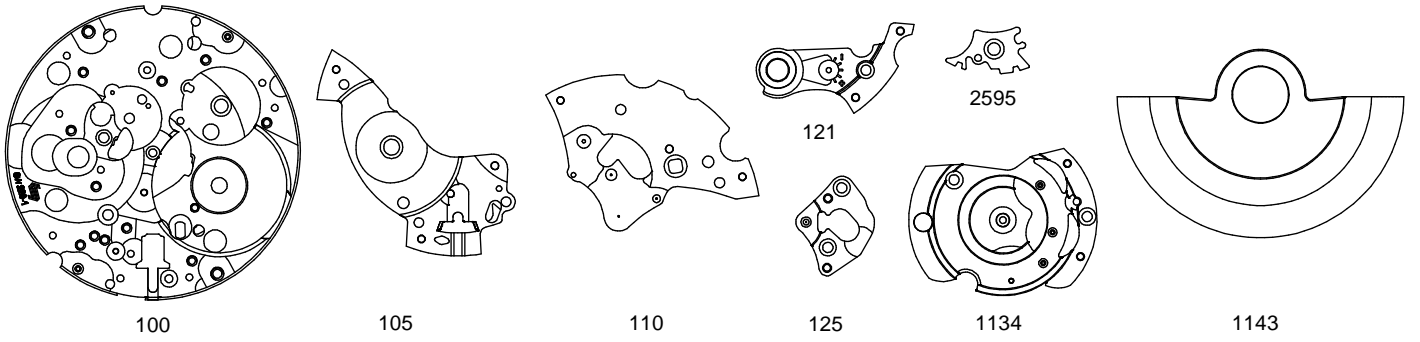

5121/5125

Code article SELLITA	Nativité	Compatible SW				Code horloger		N° plan	Désignation	Designation	Bezeichnung
		200-1	220-1	240-1	300	Nouveau	Ancien				
010.020.00006	SW220-1	<input type="checkbox"/>	<input checked="" type="checkbox"/>	<input type="checkbox"/>	<input type="checkbox"/>	10.020	100	1001	Platine - SW220-1 - Garnie	Main plate - SW220-1 - jewelled	Werkplatte - SW220-1 - mit Steinen
010.041.00001	SW200	<input checked="" type="checkbox"/>	<input checked="" type="checkbox"/>	<input checked="" type="checkbox"/>	<input type="checkbox"/>	10.041	105	1022	Pont de barillet - Garni	Barrel bridge - jewelled	Federhausbrücke - mit Steinen
010.048.00001	SW200	<input checked="" type="checkbox"/>	<input checked="" type="checkbox"/>	<input checked="" type="checkbox"/>	<input type="checkbox"/>	10.048	110	1003	Pont de rouage - Garni	Train wheel bridge - jewelled	Räderwerkbrücke - mit Steinen
010.058.00001	SW200	<input checked="" type="checkbox"/>	<input checked="" type="checkbox"/>	<input checked="" type="checkbox"/>	<input type="checkbox"/>	10.058	121	2006	Pont de balancier	Balance bridge	Unruhbrücke
010.057.00001	SW200	<input checked="" type="checkbox"/>	<input checked="" type="checkbox"/>	<input checked="" type="checkbox"/>	<input type="checkbox"/>	10.057	125	1014	Pont d'ancre - Garni	Pallet bridge - jewelled	Ankerbrücke - mit Steinen
010.300.00001	SW200	<input checked="" type="checkbox"/>	<input checked="" type="checkbox"/>	<input checked="" type="checkbox"/>	<input type="checkbox"/>	10.300	144	2947	Fixateur de cadran	Dial fastener	Zifferblatthalter
010.106.00001	SW200	<input checked="" type="checkbox"/>	<input checked="" type="checkbox"/>	<input type="checkbox"/>	<input type="checkbox"/>	10.106	145	1025	Support de cadran	Dial support	Träger für Zifferblatt
080.400.00001	SW200	<input checked="" type="checkbox"/>	<input checked="" type="checkbox"/>	<input checked="" type="checkbox"/>	<input type="checkbox"/>	80.400	161-163/1	2830	Tube de centre	Centre tube	Zentrumlagerrohr
093.030.00003	SW220-1	<input type="checkbox"/>	<input checked="" type="checkbox"/>	<input checked="" type="checkbox"/>	<input type="checkbox"/>	93.030	166	1900	Bride d'emboîtement - Courte 3.4	Casing clamp - Short 3.4	Befestigungsplättchen - Kurz 3.4
093.030.00004	SW220-1	<input type="checkbox"/>	<input checked="" type="checkbox"/>	<input checked="" type="checkbox"/>	<input type="checkbox"/>	93.030	166	1900	Bride d'emboîtement - Longue 4.25	Casing clamp - Long 4.25	Befestigungsplättchen - Lang 4.25
020.010.00002	SW200	<input checked="" type="checkbox"/>	<input checked="" type="checkbox"/>	<input checked="" type="checkbox"/>	<input type="checkbox"/>	20.010	180/1	1100	Barillet complet de mouvement - (tambour-couvercle-arbre-ressort) Monté	Movement barrel, complete - barrel, assembled	Federhaus vollständig für Grundwerk - Federhaus, montiert
020.040.00001	SW200	<input checked="" type="checkbox"/>	<input checked="" type="checkbox"/>	<input checked="" type="checkbox"/>	<input type="checkbox"/>	20.040	185	2101	Tambour de barillet	Barrel drum	Federhaustrommel
020.050.00001	SW200	<input checked="" type="checkbox"/>	<input checked="" type="checkbox"/>	<input checked="" type="checkbox"/>	<input type="checkbox"/>	20.050	190	2102	Couvercle de barillet	Barrel cover	Federhausdeckel
020.060.00001	SW200	<input checked="" type="checkbox"/>	<input checked="" type="checkbox"/>	<input checked="" type="checkbox"/>	<input type="checkbox"/>	20.060	195	2103	Arbre de barillet	Barrel arbor	Federwelle
030.014.00001	SW200	<input checked="" type="checkbox"/>	<input checked="" type="checkbox"/>	<input checked="" type="checkbox"/>	<input type="checkbox"/>	30.014	201/1	1105	Mobile de grande moyenne - (Roue Intermédiaire) - Montée	Great wheel - Assembled	Grossbodenrad - Montiert
030.025.00001	SW200	<input checked="" type="checkbox"/>	<input checked="" type="checkbox"/>	<input checked="" type="checkbox"/>	<input type="checkbox"/>	30.025	210	1108	Mobile de moyenne - Monté	Third wheel - Assembled	Kleinbodenrad - Montiert
030.027.00006	SW200	<input checked="" type="checkbox"/>	<input checked="" type="checkbox"/>	<input checked="" type="checkbox"/>	<input type="checkbox"/>	30.027	227-220	1113.04	Mobile de seconde - Aig. 4	Second wheel - Hand fitting height 4	Sekundenrad - Zeigerwerkhöhe 4
030.027.00007	SW200	<input checked="" type="checkbox"/>	<input checked="" type="checkbox"/>	<input checked="" type="checkbox"/>	<input type="checkbox"/>	30.027	227-220	1113.05	Mobile de seconde - Aig. 5	Second wheel - Hand fitting height 5	Sekundenrad - Zeigerwerkhöhe 5
030.027.00008	SW200	<input checked="" type="checkbox"/>	<input checked="" type="checkbox"/>	<input checked="" type="checkbox"/>	<input type="checkbox"/>	30.027	227-220	1113.06	Mobile de seconde - Aig. 6	Second wheel - Hand fitting height 6	Sekundenrad - Zeigerwerkhöhe 6
030.027.00009	SW200	<input checked="" type="checkbox"/>	<input checked="" type="checkbox"/>	<input checked="" type="checkbox"/>	<input type="checkbox"/>	30.027	227-220	1113.07	Mobile de seconde - Aig. 7	Second wheel - Hand fitting height 7	Sekundenrad - Zeigerwerkhöhe 7
030.027.00001	SW200	<input checked="" type="checkbox"/>	<input checked="" type="checkbox"/>	<input checked="" type="checkbox"/>	<input type="checkbox"/>	30.027	227-220	1119	Mobile de seconde - court (sans seconde)	Second wheel - short (without sec.)	Sekundenrad - kurz (ohne Sec.)
031.083.00001	SW200	<input checked="" type="checkbox"/>	<input checked="" type="checkbox"/>	<input checked="" type="checkbox"/>	<input type="checkbox"/>	31.083	247-242	1401.01	Chaussée avec entraîneur - Aig.1 montée	Cannon pinion - Hand fitting height 1 - Assembled	Minutenrohr - Zeigerwerkhöhe 1 - Montiert
031.083.00002	SW200	<input checked="" type="checkbox"/>	<input checked="" type="checkbox"/>	<input checked="" type="checkbox"/>	<input type="checkbox"/>	31.083	247-242	1401.02	Chaussée avec entraîneur - Aig.2 montée	Cannon pinion - Hand fitting height 2 - Assembled	Minutenrohr - Zeigerwerkhöhe 2 - Montiert
031.083.00003	SW200	<input checked="" type="checkbox"/>	<input checked="" type="checkbox"/>	<input checked="" type="checkbox"/>	<input type="checkbox"/>	31.083	247-242	1401.03	Chaussée avec entraîneur - Aig.3 montée	Cannon pinion - Hand fitting height 3 - Assembled	Minutenrohr - Zeigerwerkhöhe 3 - Montiert
031.083.00004	SW200	<input checked="" type="checkbox"/>	<input checked="" type="checkbox"/>	<input checked="" type="checkbox"/>	<input type="checkbox"/>	31.083	247-242	1401.04	Chaussée avec entraîneur - Aig.4 montée	Cannon pinion - Hand fitting height 4 - Assembled	Minutenrohr - Zeigerwerkhöhe 4 - Montiert
031.083.00005	SW200	<input checked="" type="checkbox"/>	<input checked="" type="checkbox"/>	<input checked="" type="checkbox"/>	<input type="checkbox"/>	31.083	247-242	1401.05	Chaussée avec entraîneur - Aig.5 montée	Cannon pinion - Hand fitting height 5 - Assembled	Minutenrohr - Zeigerwerkhöhe 5 - Montiert
031.083.00006	SW200	<input checked="" type="checkbox"/>	<input checked="" type="checkbox"/>	<input checked="" type="checkbox"/>	<input type="checkbox"/>	31.083	247-242	1401.06	Chaussée avec entraîneur - Aig.6 montée	Cannon pinion - Hand fitting height 6 - Assembled	Minutenrohr - Zeigerwerkhöhe 6 - Montiert
031.083.00007	SW200	<input checked="" type="checkbox"/>	<input checked="" type="checkbox"/>	<input checked="" type="checkbox"/>	<input type="checkbox"/>	31.083	247-242	1401.07	Chaussée avec entraîneur - Aig.7 montée	Cannon pinion - Hand fitting height 7 - Assembled	Minutenrohr - Zeigerwerkhöhe 7 - Montiert
031.046.00022	SW220-1	<input type="checkbox"/>	<input checked="" type="checkbox"/>	<input checked="" type="checkbox"/>	<input type="checkbox"/>	31.046	255-250	1406	Roue des heures - Aig.5	Hour wheel - Hand fitting height 5 - Assembled	Stundenrad - Zeigerwerkhöhe 5 - Montiert
031.046.00021	SW220-1	<input type="checkbox"/>	<input checked="" type="checkbox"/>	<input checked="" type="checkbox"/>	<input type="checkbox"/>	31.046	255-250	1406	Roue des heures - Aig.4	Hour wheel - Hand fitting height 4 - Assembled	Stundenrad - Zeigerwerkhöhe 4 - Montiert
031.046.00023	SW220-1	<input type="checkbox"/>	<input checked="" type="checkbox"/>	<input checked="" type="checkbox"/>	<input type="checkbox"/>	31.046	255-250	1406	Roue des heures - Aig.6	Hour wheel - Hand fitting height 6 - Assembled	Stundenrad - Zeigerwerkhöhe 6 - Montiert
031.041.00001	SW200	<input checked="" type="checkbox"/>	<input checked="" type="checkbox"/>	<input checked="" type="checkbox"/>	<input type="checkbox"/>	31.041	260	1407	Mobile de minuterie - Monté	Minute wheel - Assembled	Wechselrad - Montiert
040.340.00002	SW200	<input checked="" type="checkbox"/>	<input checked="" type="checkbox"/>	<input checked="" type="checkbox"/>	<input type="checkbox"/>	40.340	300	2203	Flèche de raquette (supérieure)	Regulator pointer	Rückerstiel
040.341.00001	SW200	<input checked="" type="checkbox"/>	<input checked="" type="checkbox"/>	<input checked="" type="checkbox"/>	<input type="checkbox"/>	40.341	300/6	2200	Tête de raquette (inférieure) - Montée	Regulator head - Assembled	Rückerkopf - Montiert
040.380.00001	SW200	<input checked="" type="checkbox"/>	<input checked="" type="checkbox"/>	<input checked="" type="checkbox"/>	<input checked="" type="checkbox"/>	40.380	358	2825	Correcteur de raquette - (vis réglante)	Regulator corrector	Rückerkorrektor
040.200.00001	SW200	<input checked="" type="checkbox"/>	<input checked="" type="checkbox"/>	<input checked="" type="checkbox"/>	<input type="checkbox"/>	40.200	375	2204	Porte-piton - Monté	Stud support - Assembled	Spiralklötzchen-Träger - Montiert
051.010.00001	SW200	<input checked="" type="checkbox"/>	<input checked="" type="checkbox"/>	<input checked="" type="checkbox"/>	<input type="checkbox"/>	51.010	401	1601	Tige de remontoir - longue	Winding stem - long	Aufzugwelle - lang
051.010.00002	SW200	<input checked="" type="checkbox"/>	<input checked="" type="checkbox"/>	<input checked="" type="checkbox"/>	<input type="checkbox"/>	51.010	401	1615.01	Tige de remontoir - courte - Montée (avec couronne)	Winding stem - short assembled with plastic crown	Aufzugwelle - kurz montiert mit Plastikkrone
031.121.00001	SW200	<input checked="" type="checkbox"/>	<input checked="" type="checkbox"/>	<input checked="" type="checkbox"/>	<input type="checkbox"/>	31.121	407	1602	Pignon coulant	Sliding pinion	Kupplungstrieb

Code article SELLITA	Nativité	Compatible SW				Code horloger		N° plan	Désignation	Designation	Bezeichnung
		200-1	220-1	240-1	300	Nouveau	Ancien				
031.120.00001	SW200	<input checked="" type="checkbox"/>	<input checked="" type="checkbox"/>	<input checked="" type="checkbox"/>	<input type="checkbox"/>	31.120	410	1610	Pignon de remontoir	Winding pinion	Aufzugtrieb-Kupplungsrad
031.020.00001	SW200-1	<input checked="" type="checkbox"/>	<input checked="" type="checkbox"/>	<input checked="" type="checkbox"/>	<input type="checkbox"/>	31.020	415	1300	Rochet	Ratchet wheel	Sperrad
031.023.00001	SW200	<input checked="" type="checkbox"/>	<input checked="" type="checkbox"/>	<input checked="" type="checkbox"/>	<input type="checkbox"/>	31.023	420	1304	Roue de couronne	Crown wheel	Kronrad
051.120.00001	SW200	<input checked="" type="checkbox"/>	<input checked="" type="checkbox"/>	<input checked="" type="checkbox"/>	<input type="checkbox"/>	51.120	425	1311	Cliquet	Click	Klinke
061.080.00001	SW200	<input checked="" type="checkbox"/>	<input checked="" type="checkbox"/>	<input checked="" type="checkbox"/>	<input type="checkbox"/>	61.080	430	1310	Ressort de cliquet	Click spring	Klinkenfeder
051.050.00001	SW200	<input checked="" type="checkbox"/>	<input checked="" type="checkbox"/>	<input checked="" type="checkbox"/>	<input type="checkbox"/>	51.050	435	1604	Bascule de pignon coulant	Yoke	Kupplungstriebhebel
051.080.00001	SW200	<input checked="" type="checkbox"/>	<input checked="" type="checkbox"/>	<input checked="" type="checkbox"/>	<input type="checkbox"/>	51.080	443	1606	Tirette	Setting lever	Winkelhebel
051.090.00001	SW200	<input checked="" type="checkbox"/>	<input checked="" type="checkbox"/>	<input checked="" type="checkbox"/>	<input type="checkbox"/>	51.090	445	1607	Sautoir de tirette - 3 positions	Setting lever jumper - 3 positions	Winkelhebelraste - 3 Positionen
051.090.00002	SW200	<input checked="" type="checkbox"/>	<input checked="" type="checkbox"/>	<input checked="" type="checkbox"/>	<input type="checkbox"/>	51.090	445	1607.01	Sautoir de tirette - 2 positions	Setting lever jumper - 2 positions	Winkelhebelraste - 2 Positionen
031.100.00001	SW200	<input checked="" type="checkbox"/>	<input checked="" type="checkbox"/>	<input checked="" type="checkbox"/>	<input type="checkbox"/>	31.100	450	1600	Renvoi - de mise à l'heure	Setting wheel - Setting wheel	Zeigerstellrad - Zeigerstellrad
010.062.00002	SW220-1	<input type="checkbox"/>	<input checked="" type="checkbox"/>	<input checked="" type="checkbox"/>	<input type="checkbox"/>	10.062	462	1530	Pont du rouage de minuterie	Minute train bridge	Wechselradbrücke
030.040.00001	SW200	<input checked="" type="checkbox"/>	<input checked="" type="checkbox"/>	<input checked="" type="checkbox"/>	<input type="checkbox"/>	30.040	705	1115	Mobile d'échappement - Monté	Escape wheel - Assembled	Hemmungsrad - Montiert
040.010.00001	SW200	<input checked="" type="checkbox"/>	<input checked="" type="checkbox"/>	<input checked="" type="checkbox"/>	<input type="checkbox"/>	40.010	710	1207	Ancre - Chrono - Montée	Pallet fork - Assembled (Chrono)	Anker - Montiert (Chrono)
040.010.00004	SW200	<input checked="" type="checkbox"/>	<input checked="" type="checkbox"/>	<input checked="" type="checkbox"/>	<input type="checkbox"/>	40.010	710	1207.01	Ancre - Normale - Montée	Pallet fork - Assembled	Anker - Montiert
040.050.00001	SW200	<input checked="" type="checkbox"/>	<input checked="" type="checkbox"/>	<input checked="" type="checkbox"/>	<input type="checkbox"/>	40.050	721/1	2209	Balancier annulaire - Réglé (Nickel Doré)	Annular balance - regulated (ND)	Unruh mit glattem Reif - reguliert (ND)
040.050.00008	SW200	<input checked="" type="checkbox"/>	<input checked="" type="checkbox"/>	<input checked="" type="checkbox"/>	<input type="checkbox"/>	40.050	721/1	2209.01	Balancier annulaire - Réglé (Glucydur - Chrono)	Annular balance - regulated (Glucydur - Chrono)	Unruh mit glattem Reif - reguliert (Glucydur - Chrono)
012.030.00001	SW200	<input checked="" type="checkbox"/>	<input checked="" type="checkbox"/>	<input checked="" type="checkbox"/>	<input type="checkbox"/>	12.030	1134	1010	Bâti du dispositif automatique - Garni	Automatic device mechanism - jewelled	Automatik-Mechanismus - mit Steinen
012.051.00001	SW200	<input checked="" type="checkbox"/>	<input checked="" type="checkbox"/>	<input checked="" type="checkbox"/>	<input type="checkbox"/>	12.051	1141	1027	Pont inférieur du dispositif automatique - Garni	Automatic device lower bridge - jewelled	Untere Brücke für Automatik - mit Steinen
022.010.00018	SW200	<input checked="" type="checkbox"/>	<input checked="" type="checkbox"/>	<input checked="" type="checkbox"/>	<input type="checkbox"/>	22.010	1143	1007	Masse oscillante - sans marque	Oscillating weight - without engraving	Schwungmasse - ohne Gravur
022.010.00002	SW200	<input checked="" type="checkbox"/>	<input checked="" type="checkbox"/>	<input checked="" type="checkbox"/>	<input type="checkbox"/>	22.010	1143	1007.01	Masse oscillante - gravée 26 JEWELS	Oscillating weight - engraved, 26 JEWELS	Schwungmasse - graviert, 26 JEWELS
032.031.00001	SW200-1	<input checked="" type="checkbox"/>	<input checked="" type="checkbox"/>	<input checked="" type="checkbox"/>	<input type="checkbox"/>	32.031	1481	1701	Mobile de réduction	Reduction wheel	Reduktionsrad
032.033.00001	SW200-1	<input checked="" type="checkbox"/>	<input checked="" type="checkbox"/>	<input checked="" type="checkbox"/>	<input type="checkbox"/>	32.033	1482	1704	Mobile entraîneur de rochet	Ratchet wheel driving wheel	Mitnehmerrad für Sperrad
022.040.00001	SW200	<input checked="" type="checkbox"/>	<input checked="" type="checkbox"/>	<input checked="" type="checkbox"/>	<input type="checkbox"/>	22.040	1497	1712	Roulement à billes	Ball bearing	Kugellager
032.037.00001	SW200	<input checked="" type="checkbox"/>	<input checked="" type="checkbox"/>	<input checked="" type="checkbox"/>	<input type="checkbox"/>	32.037	1535-1488	1733	Mobile d'inversion - (roue à cliquets) - Monté	Reversing wheel - Assembled	Umkehrad - Montiert
032.038.00001	SW200	<input checked="" type="checkbox"/>	<input checked="" type="checkbox"/>	<input checked="" type="checkbox"/>	<input type="checkbox"/>	32.038	1545	1734	Mobile auxiliaire d'inversion - Monté	Auxiliary reversing wheel - Assembled	Hilfs-Umkehrad - Montiert
033.011.00003	SW220-1	<input type="checkbox"/>	<input checked="" type="checkbox"/>	<input checked="" type="checkbox"/>	<input type="checkbox"/>	33.011	2543	1527	Mobile intermédiaire de quantième	Intermediate date wheel	Datum-Zwischenrad
033.028.00001	SW220-1	<input type="checkbox"/>	<input checked="" type="checkbox"/>	<input checked="" type="checkbox"/>	<input type="checkbox"/>	33.028	2555	1533	Mobile entraîneur du calendrier	Calendar driving wheel	Kalender-Mitnehmerrad
091.440.00011	SW220	<input type="checkbox"/>	<input checked="" type="checkbox"/>	<input type="checkbox"/>	<input type="checkbox"/>	91.440	2557/1	.	Indicateur de quantième - Décalque Noire - Fond Blanc - Guichet 3H (SW220-1)	Date indicator - Black print - White background - Aperture 3 o'clock	Datumanzeiger - Schwarzer Druck - Weisser Hintergrund - Fenster 3 Uhr
091.440.00005	SW220-1	<input type="checkbox"/>	<input checked="" type="checkbox"/>	<input type="checkbox"/>	<input type="checkbox"/>	91.440	2557/1	1545	Indicateur de quantième - Brut	Date indicator - unfinished	Datumanzeiger - roh
091.441.00003	SW220-1	<input type="checkbox"/>	<input checked="" type="checkbox"/>	<input type="checkbox"/>	<input type="checkbox"/>	91.441	2561/1	1538	Indicateur du jour - Brut Monté	Day indicator - unfinished assembled	Tagesanzeiger - roh montiert
091.441.00013	SW220-1	<input type="checkbox"/>	<input checked="" type="checkbox"/>	<input type="checkbox"/>	<input type="checkbox"/>	91.441	2561/1	1538	Indicateur du jour - Décalque Noire - Fond Blanc - Guichet 3H - Langue à préciser	Day indicator - Black print - White background - Aperture 3 o'clock - Specify language	Tagesanzeiger - Schwarzer Druck - Weisser Hintergrund - Fenster 3 Uhr - Sprache angeben
053.201.00001	SW220-1	<input type="checkbox"/>	<input checked="" type="checkbox"/>	<input checked="" type="checkbox"/>	<input type="checkbox"/>	53.201	2567	1523	Correcteur des jours - Monté	Day corrector - Assembled	Tageskorrektor - Montiert
053.204.00001	SW220-1	<input type="checkbox"/>	<input checked="" type="checkbox"/>	<input checked="" type="checkbox"/>	<input type="checkbox"/>	53.204	2569	1517	Correcteur double	Double corrector	Doppelkorrektor
053.026.00001	SW200	<input checked="" type="checkbox"/>	<input checked="" type="checkbox"/>	<input checked="" type="checkbox"/>	<input type="checkbox"/>	53.026	2570	1605	Commande du correcteur double	Double corrector operating lever	Schalthebel für Doppelkorrektor
053.080.00001	SW200	<input checked="" type="checkbox"/>	<input checked="" type="checkbox"/>	<input checked="" type="checkbox"/>	<input type="checkbox"/>	53.080	2576	1512	Sautoir de quantième	Date jumper	Datumraste
013.111.00005	SW220-1	<input type="checkbox"/>	<input checked="" type="checkbox"/>	<input checked="" type="checkbox"/>	<input type="checkbox"/>	13.111	2595	2012	Plaque de maintien du sautoir de quantième	Date jumper maintaining plate	Halteplatte für Datumraste
053.040.00001	SW220-1	<input type="checkbox"/>	<input checked="" type="checkbox"/>	<input checked="" type="checkbox"/>	<input type="checkbox"/>	53.040	2632	1532	Bascule de déclenchement de quantième	Date unlocking yoke	Auslösewippe für Datum
063.012.00001	SW220-1	<input type="checkbox"/>	<input checked="" type="checkbox"/>	<input checked="" type="checkbox"/>	<input type="checkbox"/>	63.012	2633	1531	Ressort de bascule de déclenchement	Unlocking yoke spring	Feder für Auslösewippe
013.109.00001	SW220-1	<input type="checkbox"/>	<input checked="" type="checkbox"/>	<input checked="" type="checkbox"/>	<input type="checkbox"/>	13.109	2644	1522	Plaque de maintien de bascule de déclenchement	Unlocking yoke maintaining plate	Halteplatte für Auslösewippe



Code article SELLITA	Nativité	Compatible SW				Code horloger		N° plan	Désignation	Designation	Bezeichnung
		200-1	220-1	240-1	300	Nouveau	Ancien				
083.171.00001	SW220-1	<input type="checkbox"/>	<input checked="" type="checkbox"/>	<input checked="" type="checkbox"/>	<input type="checkbox"/>	83.171	2780	1543	Clavette de l'indicateur du jour	Day indicator spring-clip	Klemmscheibe für Tagesanzeiger
053.089.00001	SW220-1	<input type="checkbox"/>	<input checked="" type="checkbox"/>	<input checked="" type="checkbox"/>	<input type="checkbox"/>	53.089	2784	1544	Sautoir double	Double jumper	Doppelraste
070.500.00001	SW200	<input checked="" type="checkbox"/>	<input checked="" type="checkbox"/>	<input checked="" type="checkbox"/>	<input type="checkbox"/>	70.500	3024	2223	Amortisseur (antichoc) empierré, à chasser, à portée, de balancier, SUS - (Inca-coq)	Jewelled shock-absorber, shouldered, to press in, for balance, TOP - INCA	StoBsicherung mit Stein, Zum Einpressen, mit Auflage, für Unruh, OBEN - INCA
070.500.00002	SW200	<input checked="" type="checkbox"/>	<input checked="" type="checkbox"/>	<input checked="" type="checkbox"/>	<input type="checkbox"/>	70.500	3024	2223.01	Amortisseur (antichoc) empierré, à chasser, à portée, de balancier, SUS - (Novo-coq)	Jewelled shock-absorber, shouldered, to press in, for balance, TOP - NOVO	StoBsicherung mit Stein, Zum Einpressen, mit Auflage, für Unruh, OBEN - NOVO
070.501.00001	SW200	<input checked="" type="checkbox"/>	<input checked="" type="checkbox"/>	<input checked="" type="checkbox"/>	<input type="checkbox"/>	70.501	3025	2224	Amortisseur (antichoc) empierré, à chasser, à portée, de balancier, SOUS - (Inca-platine)	Jewelled shock-absorber, shouldered, to press in, for balance, BOTTOM - INCA	StoBsicherung mit Stein, Zum Einpressen, mit Auflage, für Unruh, UNTEN - INCA
070.501.00002	SW200	<input checked="" type="checkbox"/>	<input checked="" type="checkbox"/>	<input checked="" type="checkbox"/>	<input type="checkbox"/>	70.501	3025	2224.01	Amortisseur (antichoc) empierré, à chasser, à portée, de balancier, SOUS - (Novo-platine)	Jewelled shock-absorber, shouldered, to press in, for balance, BOTTOM - NOVO	StoBsicherung mit Stein, Zum Einpressen, mit Auflage, für Unruh, UNTEN - NOVO
056.070.00001	SW200	<input checked="" type="checkbox"/>	<input checked="" type="checkbox"/>	<input checked="" type="checkbox"/>	<input type="checkbox"/>	56.070	9433	1410	Levier stop	Stop lever	Stopphebel
088.586.00002	SW220-1	<input type="checkbox"/>	<input checked="" type="checkbox"/>	<input checked="" type="checkbox"/>	<input type="checkbox"/>	88.586	52567	1816	Vis à portée, tête bombée, bout plat - S0,70 (du correcteur des jours)	Shouldered convex head screw, flat end - S0,70 (day corrector)	Linsenansatzschraube mit Kegelpuppe - S0,70 (Tageskorrektor)
088.514.00004	SW200	<input checked="" type="checkbox"/>	<input checked="" type="checkbox"/>	<input checked="" type="checkbox"/>	<input type="checkbox"/>	88.514	5101	1817	Vis à tête cylindrique, renforcée, bombée, bout plat - de fixation fraisée (sans bride) (x2)	Cylindrical reinforced convex head screw, flat end - case screw, special (x2)	Linsenzylinderschraube verstärkt mit Kegelpuppe - Schraube für Werkbefestigung, spezial
088.515.00001	SW200	<input checked="" type="checkbox"/>	<input checked="" type="checkbox"/>	<input checked="" type="checkbox"/>	<input type="checkbox"/>	88.515	5415	1818	Vis à tête cylindrique, renforcée, bombée, bout à pivot - vis de rochet (Pos 2)	Cylindrical reinforced convex head screw, pivot end - screw for ratchet wheel	Linsenzylinderschraube verstärkt mit Zapfen - Schraube für Sperrrad
088.506.00001	SW200	<input checked="" type="checkbox"/>	<input checked="" type="checkbox"/>	<input checked="" type="checkbox"/>	<input type="checkbox"/>	88.506	51141	1819	Vis à tête cylindrique, bombée, bout plat - de pont inférieur (Pos206)	Cylindrical convex head screw, flat end - automatic device lower bridge (Pos.206)	Linsenzylinderschraube mit Kegelpuppe - untere Brücke für Automatik
088.514.00001	SW200	<input checked="" type="checkbox"/>	<input checked="" type="checkbox"/>	<input checked="" type="checkbox"/>	<input type="checkbox"/>	88.514	51497	1820	Vis à tête cylindrique, renforcée, bombée, bout plat - vis de roulement à bille (Pos1)	Cylindrical reinforced convex head screw, flat end - ball bearing screw (Pos.1)	Linsenzylinderschraube verstärkt mit Kegelpuppe - Kugellagerschraube
088.514.00002	SW200	<input checked="" type="checkbox"/>	<input checked="" type="checkbox"/>	<input checked="" type="checkbox"/>	<input type="checkbox"/>	88.514	5102	1821	Vis à tête cylindrique, renforcée, bombée, bout plat - de fixation (sans bride) (x2, Pos130-131)	Cylindrical reinforced convex head screw, flat end - case screw (x2, Pos130-131)	Linsenzylinderschraube verstärkt mit Kegelpuppe - Schraube für Werkbefestigung
088.514.00003	SW200	<input checked="" type="checkbox"/>	<input checked="" type="checkbox"/>	<input checked="" type="checkbox"/>	<input type="checkbox"/>	88.514	5420	1822	Vis à tête cylindrique, renforcée, bombée, bout plat - vis de couronne (Pos200)	Cylindrical reinforced convex head screw, flat end - screw for crown wheel (Pos.200)	Linsenzylinderschraube verstärkt mit Kegelpuppe - Kronradschraube
088.586.00001	SW200	<input checked="" type="checkbox"/>	<input checked="" type="checkbox"/>	<input checked="" type="checkbox"/>	<input type="checkbox"/>	88.586	51134	1823	Vis à portée, tête bombée, bout plat - de bâti de dispositif automatique (x2 Pos203-204)	Shouldered convex head screw, flat end - on automatic device mechanism (x2, Pos.203-204)	Linsenansatzschraube mit Kegelpuppe - über Automatik-Mechanismus (x2, Pos.203-204)
088.546.00002	SW200	<input checked="" type="checkbox"/>	<input checked="" type="checkbox"/>	<input checked="" type="checkbox"/>	<input checked="" type="checkbox"/>	88.546	5166	1824	Vis à tête conique 90°, bombée, bout plat - M1,00 (2x sur bride sur SW2x0 Pos130-131 et SW300 Pos75-76)	90° countersunk convex head screw, flat end - M1,00 (2x on casing clamp, pos.130-131 and SW300 Pos.75-76)	Linsensenkschraube 90° mit Kegelpuppe - M1,00 (2x über befestigungsplättchen, pos.130-131 und SW300 Pos.75-76)
088.546.00001	SW200	<input checked="" type="checkbox"/>	<input checked="" type="checkbox"/>	<input checked="" type="checkbox"/>	<input type="checkbox"/>	88.546	5105-5110-5121-5125	1827	Vis à tête conique 90°, bombée, bout plat - de pont rouage (x2), balancier (x1), ancre (x2), barillet (x3)	90° countersunk convex head screw, flat end - train wheel bridge (x2), balance bridge (x1), pallet bridge (x2), barrel bridge	Linsensenkschraube 90° mit Kegelpuppe - räderwerkbrücke (x2), unruhbrücke (x1), ankerbrücke (x2), federhausbrücke (x3)
088.547.00001	SW200	<input checked="" type="checkbox"/>	<input checked="" type="checkbox"/>	<input checked="" type="checkbox"/>	<input type="checkbox"/>	88.547	5445-52595	1828	Vis à tête conique 90°, bombée, bout à pivot - sur plaque maintien indicateur quantième (1xPos25)-sautoir de tirette (1xPos50)	90° countersunk convex head screw, pivot end - date jumper maintaining plate	Linsensenkschraube 90° mit Zapfen - Halteplatte für Datumraste
088.587.00002	SW220-1	<input type="checkbox"/>	<input checked="" type="checkbox"/>	<input checked="" type="checkbox"/>	<input type="checkbox"/>	88.587	5462	1829	Vis à portée, tête bombée, bout à pivot - de pont de rouage de minuterie	Shouldered convex head screw, pivot end - on minute train bridge	Linsenansatzschraube mit Zapfen - über Wechselradbrücke

Roue Rad Wheel	Cage Uhrwerkgestell Frame	Ø Trou Ø Loch Ø Hole	Ø Total Ø Gesamt Ø Total	Epaisseur Dicke Thickness	Genre Art Type	Pierres Steine Jewels
Balancier antichoc Unruh für Stosssicherung Balance for shock absorber	Pont de balancier Unruhebrücke Balance bridge	0,09	1,90		Amortisseur Stosssicherung Shock-absorber	26
Balancier antichoc Unruh für Stosssicherung Balance for shock absorber	Platine Werkplatte Main plate	0,09	1,90		Amortisseur Stosssicherung Shock-absorber	26
Ancre Anker Pallet fork	Pont d'ancre Ankerbrücke Pallet fork bridge	0,10	0,90	0,18	Bombée, trou cyl. Bombiert, zyl. Bohrung Convex, cyl. hole	26
Ancre Anker Pallet fork	Platine Werkplatte Main plate	0,10	0,90	0,18	Bombée, trou cyl. Bombiert, zyl. Bohrung Convex, cyl. hole	26
Roue d'échappement Ankerad Escape wheel	Pont de rouage Räderbrücke Wheel bridge	0,10	0,70	0,16	Glace, trou olivé Flach, oliviert Bohrung Flat, olived hole	26
Roue d'échappement Ankerad Escape wheel	Platine Werkplatte Main plate	0,10	0,90	0,18	Glace, trou olivé Flach, oliviert Bohrung Flat, oliviert Bohrung	26
Roue de seconde Sekundenrad Second wheel	Pont de rouage Räderbrücke Wheel bridge	0,14	1,00	0,18	Glace, trou cyl. Flach, zyl. Bohrung Flat, cyl. hole	26
Roue de moyenne Kleinbodenrad Third wheel	Pont de rouage Räderbrücke Wheel bridge	0,14	1,00	0,14	Glace, trou cyl. Flach, zyl. Bohrung Flat, cyl. hole	26
Roue de moyenne Kleinbodenrad Third wheel	Platine Werkplatte Main plate	0,19	0,60	0,30	Glace, trou cyl. Flach, zyl. Bohrung Flat, cyl. hole	26
Roue de G. moyenne Grossbodenrad Intermediate wheel	Pont de barillet Federhausbrücke Barrel bridge	0,30	1,20	0,30	Glace, trou cyl. Flach, zyl. Bohrung Flat, cyl. hole	26
Roue de G. moyenne Grossbodenrad Intermediate wheel	Platine Werkplatte Main plate	0,30	1,20	0,30	Glace, trou cyl. Flach, zyl. Bohrung Flat, cyl. hole	26
Barillet Federhaus Barrel	Pont de barillet Federhausbrücke Barrel bridge	1,40	2,00	0,35	Glace, sans creusure Flach, ohne Hölung Flat, without oil well	26
Barillet Federhaus Barrel	Platine Werkplatte Main plate	0,70	1,40	0,40	Glace, sans creusure Flach, ohne Hölung Flat, without oil well	26
Roue de réduction Reduktionsrad Reduction wheel	Pont inférieur Unterebrücke Lower bridge	0,25	0,70	0,20	Glace, trou cyl. Flach, zyl. Bohrung Flat, cyl. hole	26
Roue de réduction Reduktionsrad Reduction wheel	Bâti automatique Automatikbrücke Automatic bridge	0,25	0,80	0,20	Glace, trou cyl. Flach, zyl. Bohrung Flat, cyl. hole	26
Roue d'inversion Umkehrad Reversing wheel	Pont inférieur Unterebrücke Lower bridge	0,25	0,70	0,20	Glace, trou cyl. Flach, zyl. Bohrung Flat, cyl. hole	26
Roue d'inversion Umkehrad Reversing wheel	Bâti automatique Automatikbrücke Automatic bridge	0,25	0,80	0,20	Glace, trou cyl. Flach, zyl. Bohrung Flat, cyl. hole	26
Roue auxiliaire d'inversion Hilfs-Umkehrad Auxiliary reversing wheel	Pont inférieur Unterebrücke Lower bridge	0,25	0,70	0,20	Glace, trou cyl. Flach, zyl. Bohrung Flat, cyl. hole	26
Roue auxiliaire d'inversion Hilfs-Umkehrad Auxiliary reversing wheel	Bâti automatique Automatikbrücke Automatic bridge	0,25	0,80	0,20	Glace, trou cyl. Flach, zyl. Bohrung Flat, cyl. hole	26
Roue d'inversion Umkehrad Reversing wheel	Roue supérieure Oberes Rad Upper wheel	0,42	0,80	0,16	Glace, sans creusure Flach, ohne Hölung Flat, without oil well	26



# SW 220-1

Calibre automatique 11½", fréquence 4Hz  
26 Jewels, Swiss Made

**Assortiment**  
**Assortiment**  
**Assortiment**

EXECUTION / AUSFÜHRUNG / RANGE	Standard	Spécial (Elaboré)	Premium (Top)	Chronomètre
Roue d'échappement Hemmungsrads Escape wheel	Acier, plat poli, un biseau, inclinés polis, épilamée, Lubrifar. Stahl, flachpoliert, 1 Abschrägung, polierte Hebungflächen, epilamisiert, Lubrifar. Steel, flat polished, 1 bevel, polished inclinations, epilame-coated, Lubrifar.			
Ancre Anker Pallet fork	Acier, plat poli, entrée bercée, renversements bercés. Stahl, flachpoliert, Gabeleinschnitt abgerundet, Anschläge gerundet. Steel, flat polished, rounded-off lever-notch, rounded-up pallet cock.			
Levées Hebesteine Pallet stones	Rubis rouge, épilamées. Roter Rubin, epilamisiert. Red ruby, epilame-coated.			
Balancier Unruh Balance wheel	Nickel doré Nickel vergoldet Nickel gilt		Glucydur doré Glucydur vergoldet Glucydur gilt	
Amortisseur de chocs Stossdämpfer Shock absorber	Novodiac		Incabloc	
Virole Spiralrolle Collet	Nivatronic			
Angle de levée Hebungswinkel Lift angle	50°			
Positions Lagen Positions	(2) CH, 6H	(3) CH, 6H, 9H	(5) CH, FH 6H, 9H, 3H	Critères COSC  COSC Kriterien  COSC criteria
Marche moyenne (0h) Mittelwert Gang (0Std.) Average rate (0h)	12 ±12 s/d	7 ±7 s/d	4 ±4 s/d	
Marche moyenne (24h) Mittelwert Gang (24Std.) Average rate (24h)	30 s	20 s	15 s	
Isochronisme (CH 0h – CH 24h) Isochronismus (CH 0Std. - CH 24Std.) Isochronism (CH 0h – CH 24h)	± 20 s/d	± 15 s/d	± 10 s/d	
Amplitude max. (CH 0h) Max. Schwingungsweite (CH 0Std.) Max. amplitude (CH 0h)	315°			
Amplitude min. (6H 24h) Min. Schwingungsweite (6H 24Std.) Min. amplitude (6H 24h)	200°			
Repère max. (CH 0h) Abfall Maxi. (CH 0Std.) Adjusting max (CH 0h)	0.8 ms		0.6 ms	
Temps de stabilisation Stabilisationszeit Stabilisation time	20 s			
Temps de mesure Messungszeit Measuring time	40 s			

Différences admises				
	Standard	Spécial	Premium	Chronomètre
Marche	±7 s/d	±5 s/d	±5 s/d	±3 s/d
Amplitude	±10°	±10°	±10°	±10°

Spécifications techniques Technische Spezifikationen Technical specifications	
Forme et genre Form und Art Shape and type	Calibre rond, échappement à ancre, mouvement mécanique automatique Rundes Kaliber, mechanisches Ankerwerk, automatischer Aufzug Round caliber, mechanical lever movement, self winding
Fréquence Frequenz Frequency	28800 alternances par heures, 4 Hz 28800 Halbschwingungen pro Stunde, 4 Hz 28800 vibrations per hour, 4 Hz
Pierres Steine Jewels	26
Diamètre total Gesamtdurchmesser Overall diameter	26.20 mm
Diamètre d'encourageage Gehäusepassungsdurchmesser Case fitting diameter	25.60 mm
Hauteur Höhe Height	4.80 mm
Fonctions Funktionen Functions	Affichage par aiguilles Heures, Minutes, Seconde. Quantième à guichet. Anzeige durch Zeiger Stunden, Minuten, Sekunden. Datumanzeige im Fenster. Display by means of hands Hours, Minutes, Seconds. Date display in window.
Tige de remontoir Aufzugwelle Winding stem	3 positions : 1) Remontage manuel, 2) Correction rapide de date, 3) Mise à l'heure 3 Stellungen : 1) Handaufzug, 2) Schnellkorrektur des Datums, 3) Zeigerstellung 3 positions : 1) Manual winding, 2) Quick correction of date, 3) Time setting
Masse oscillante Schwungmasse Oscillating weight	Avec segment en métal lourd et roulement à billes Mit Schwermetallsegment und Kugellager With segment of heavy metal and ball bearing.
Stop seconde Sekundenstopp Stop seconds	Avec Mit With
Réglage fin Feinregulierung Fine timing device	Avec Mit With
Ressort de barillet Zugfeder Barrel spring	M½ : 1170-1210 p.mm Nivaflex M24 (min.) : 900 p.mm
Moment de glissement Gleitmoment Sliding moment	Min. 1245 p.mm Max. 1690 p.mm
Réserve de marche Gangreserve Power reserve	Position CH (min.) 38 Std. H H

	Positions selon les normes NIHS Positionen nach den NIHS-Normen Positions according to the norms NIHS	Désignations courantes pour horlogers Gebräuchliche Bezeichnungen für Uhrmacher Common designations for watchmakers
<b>CH</b>	Horizontale cadran en haut Horizontal Zifferblatt Oben Horizontal dial up	HH Horizontale Haut ZO Zifferblatt Oben DU Dial Up
<b>FH</b>	Horizontale fond en haut Horizontal Zifferblatt Unten Horizontal dial down	HB Horizontale Bas ZU Zifferblatt Unten DD Dial Down
<b>6H</b>	Verticale 6H en haut Vertikal 6H Oben Vertical 6 o'clock up	VG Verticale Gauche KL Krone Links PL Position Left
<b>9H</b>	Verticale 9H en haut Vertikal 9H Oben Vertical 9 o'clock up	VB Verticale Bas KU Krone Unten PD Position Down
<b>3H</b>	Verticale 3H en haut Vertikal 3H Oben Vertical 3 o'clock up	VH Verticale Haut KO Krone Oben PU Position Up

**REMARQUES IMPORTANTES** : Les critères de marche sont donnés à titre indicatif étant admis qu'il est possible de régler le mouvement par simple correction de la raquette, c'est à dire sans avoir à refaire une mise en marche complète

Les contrôles à armage haut, désignées par 0h, se font entre 1 et 3 heures après armage complet, sans calendrier en prise. De plus lors du contrôle des marches instantanées et des amplitudes il faut impérativement tenir compte des imprécisions de mesure dues aux appareils et aux différences de T° agissant sur les réglages.

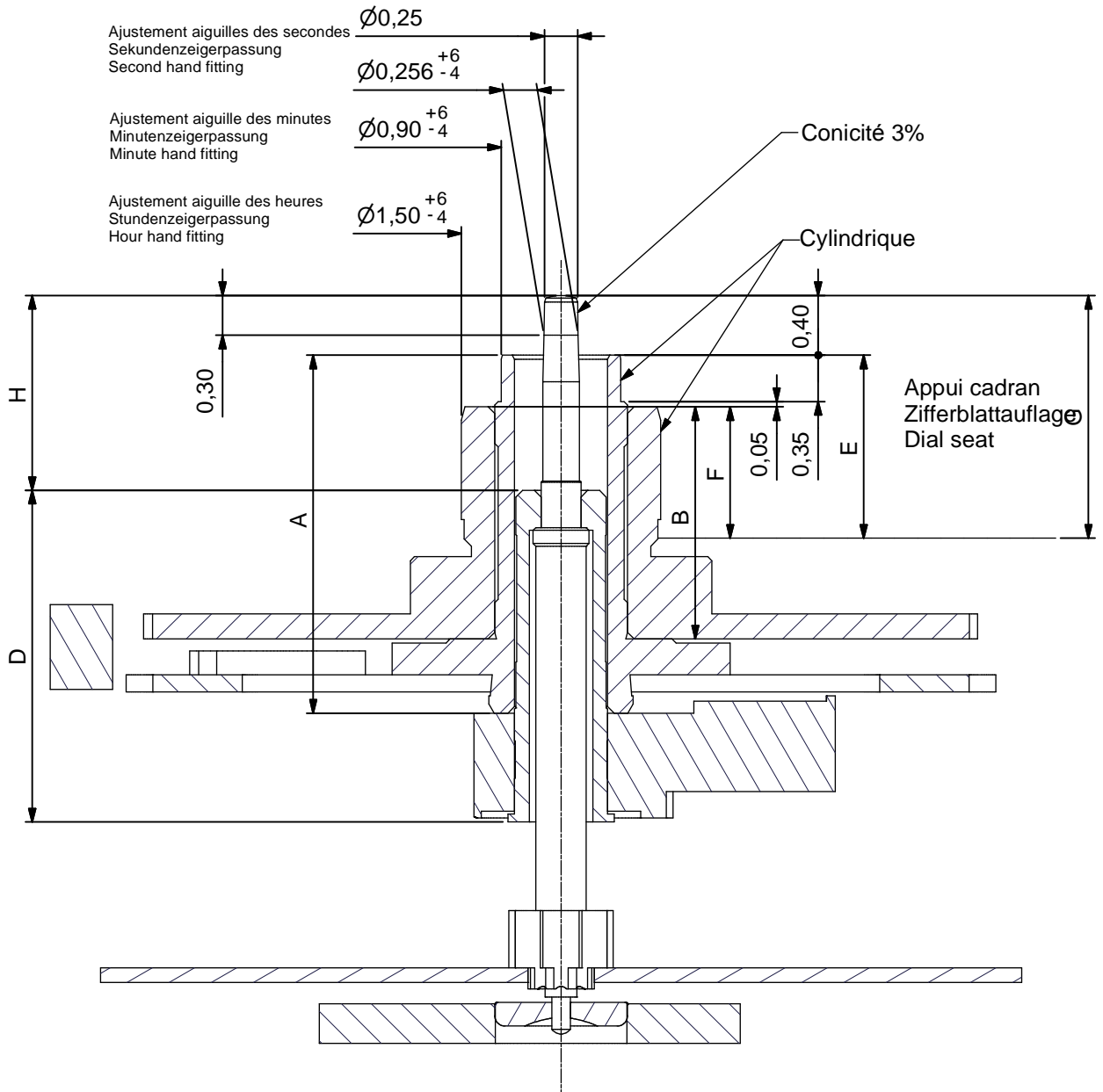

Aiguillage Zeigerwerk öhe Hand fitting height	Longueur / Länge / Length				Dépassement / Höhe über Zifferblattauflage / Height over dial seat			H
	A	B	C	D	E	F	G	
	Chaussée	Roue des heures	Fig. de sec.	Tube de centre	Chaussée	Roue des heures	Fig. de sec.	
	Minutenrohr	Stundenrad	Skudentrieb	Zentrumrohr	Minutenrohr	Stundenrad	Skudentrieb	
	Cannon - pinion	Hourw heel	Sec. w heel pin.	Centre tube	Cannon - pinion	Hourw heel	Sec. w heel pin.	
3	2.45	1.50	5.32	2.50	1.15	0.75	1.55	1.20
4 normal	2.70	1.75	5.57	2.50	1.40	1.00	1.80	1.45
5	2.95	2.00	5.82	2.50	1.65	1.25	2.05	1.70
6	3.20	2.25	6.07	2.50	1.90	1.50	2.30	1.95



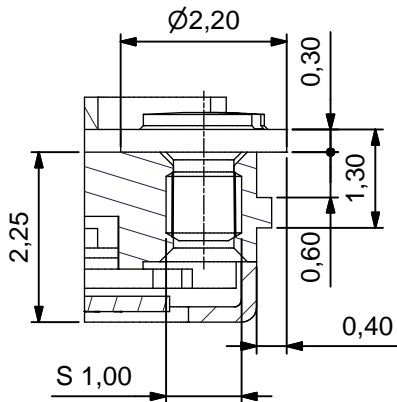

Position des vis d'embôttage  
Position der Einschalungsschraube  
Casing screw position

Position intérieure  
12,8 Innere Stellung  
Inner position

Course de la tige  
0,8 Weg der Stellwelle  
Length of travel of stem

