

TECHNICAL GUIDE **AND** **PARTS LIST**

CAL. V233A

ANALOGUE QUARTZ

CONTENTS

I. SPECIFICATIONS	1
II. LIST OF SCREWS USED	1
III. DISASSEMBLING, REASSEMBLING AND LUBRICATING	2 ~ 4
IV. CHECKING AND ADJUSTMENT	5 ~ 6
V. PARTS LIST	7

I. SPECIFICATIONS

Item		Cal. No.	V233A
Indication system		Three hands	
Driving system		Step motor (fixed pulse system)	
Additional mechanism		Second setting devise Electric reset switch	
Loss/gain		Monthly rate: Less than 20 seconds at normal temperature range	
Movement size	Size of main plate	15.5 mm (6-12H), 13.0 mm (3-9H)	
	Casing diameter	15.1 mm	
	Height	2.4 mm	
Regulation system		---	
Quartz Tester measuring gate		10-second gate	
Battery		SEIKO TR521SW, MAXELL SR521SW, SONY EVEREADY 379 Voltage: 1.55V Battery life: Approx. 2 years for SEIKO TR521SW and SONY EVEREADY 379 Approx. 1.5 years for MAXELL SR521SW	
Jewels		1 jewel	



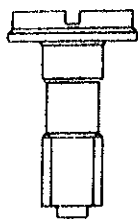
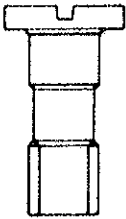
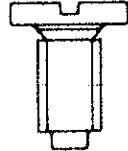
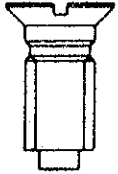
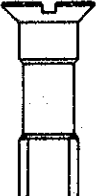

II. LIST OF SCREWS USED

				
012 010	012 064	012 495	012 818	012 819
Battery clamp screw (1 pce.)	Train wheel bridge screw (1 pce.)	Circuit block screw (1 pce.)	Screw for battery connection (+) (A) (2 pcs.)	Screw for battery connection (+) (B) (1 pce.)

III. DISASSEMBLING, REASSEMBLING AND LUBRICATING

Disassembling procedures: Figs. ① → ④
Reassembling procedures: Figs. ④ → ①

Lubricating:

Types of oil	Oil quantity
Moebius A 	Small 
Seiko oil S-6 	Standard 

- Hands ~ Hour wheel
- How to remove the winding stem

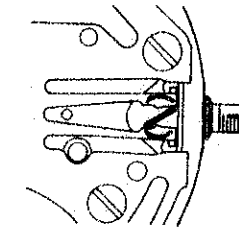

Insert a little bit large (-) screwdriver and turn it alternately right and left (in the direction of the arrow shown in the above figure) to remove the winding stem.

② Dial

The dial is fixed with its 2 legs inserted into the dial leg holes in the dial spacer ③.

* To remove the dial, insert a (-) screwdriver into the opening notch for dial at 2 and 7 o'clock position and pry out the dial alternately.

NOTES ON ATTACHING THE HANDS:

- When attaching the hands, place the movement on a flat metal plate.

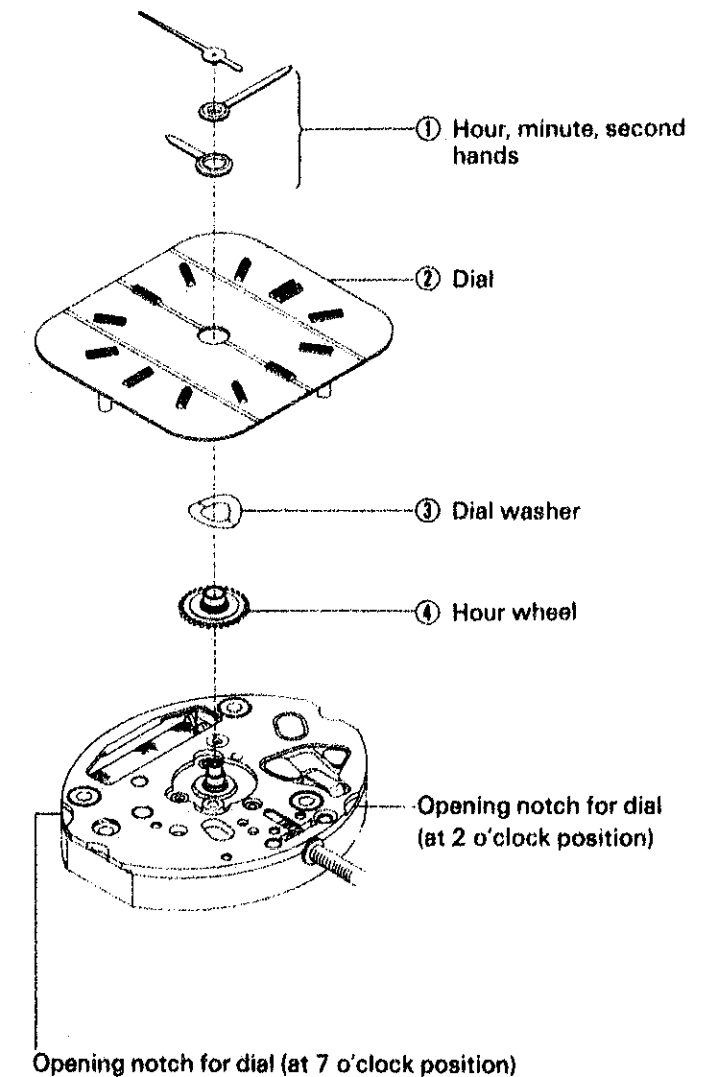

● Battery clamp screw ~ Winding stem

* In some models, a battery clamp and battery clamp screw are used.

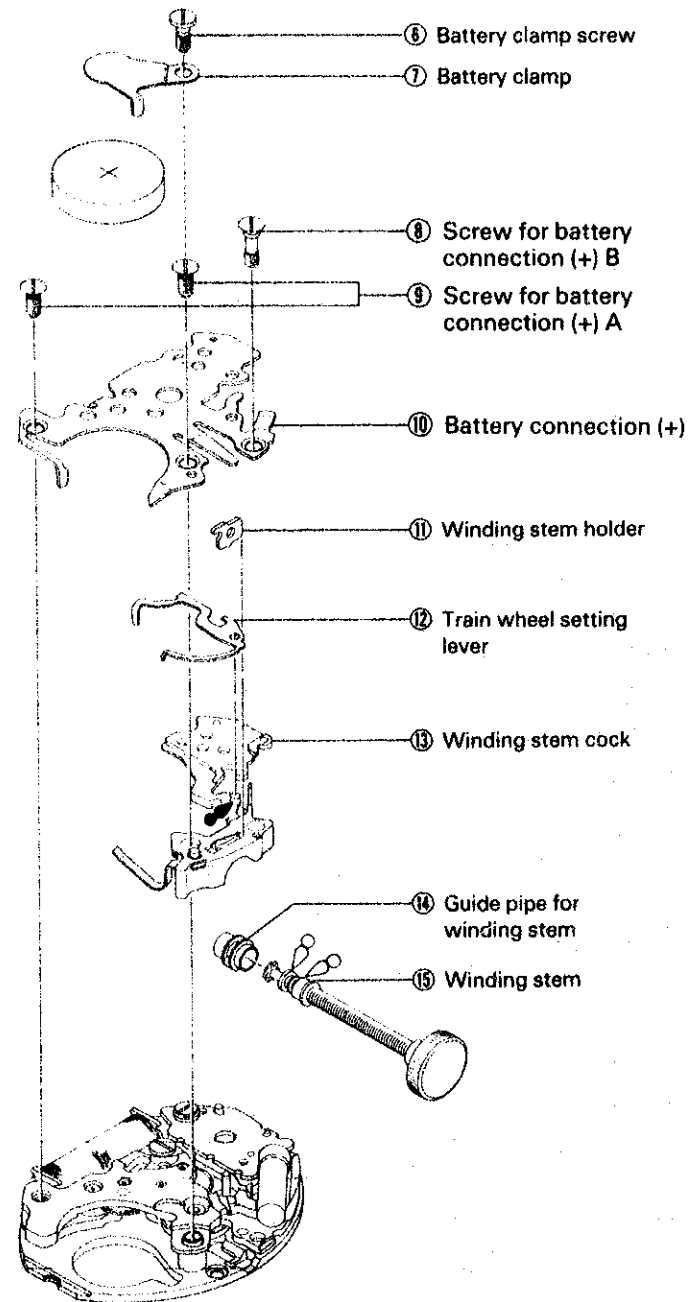

⑭ Guide pipe for winding stem

Install the guide pipe for winding stem so that the grooved side is positioned outwards. The two flat surfaces should be positioned in the groove in the main plate as shown in the illustrations.

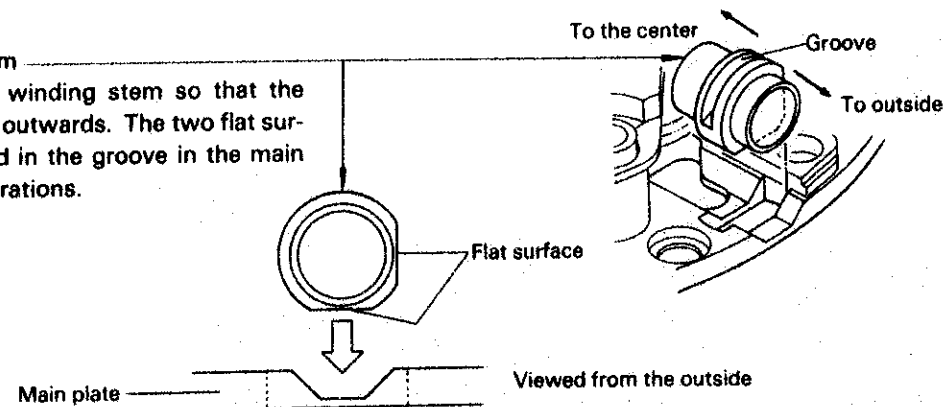

● Train wheel bridge screw ~ Main plate

Cross-sectional view of gear train

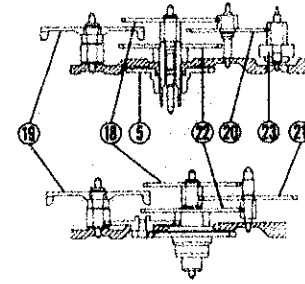

Plan figure

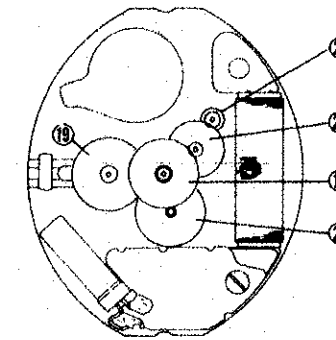

Set position of reset lever

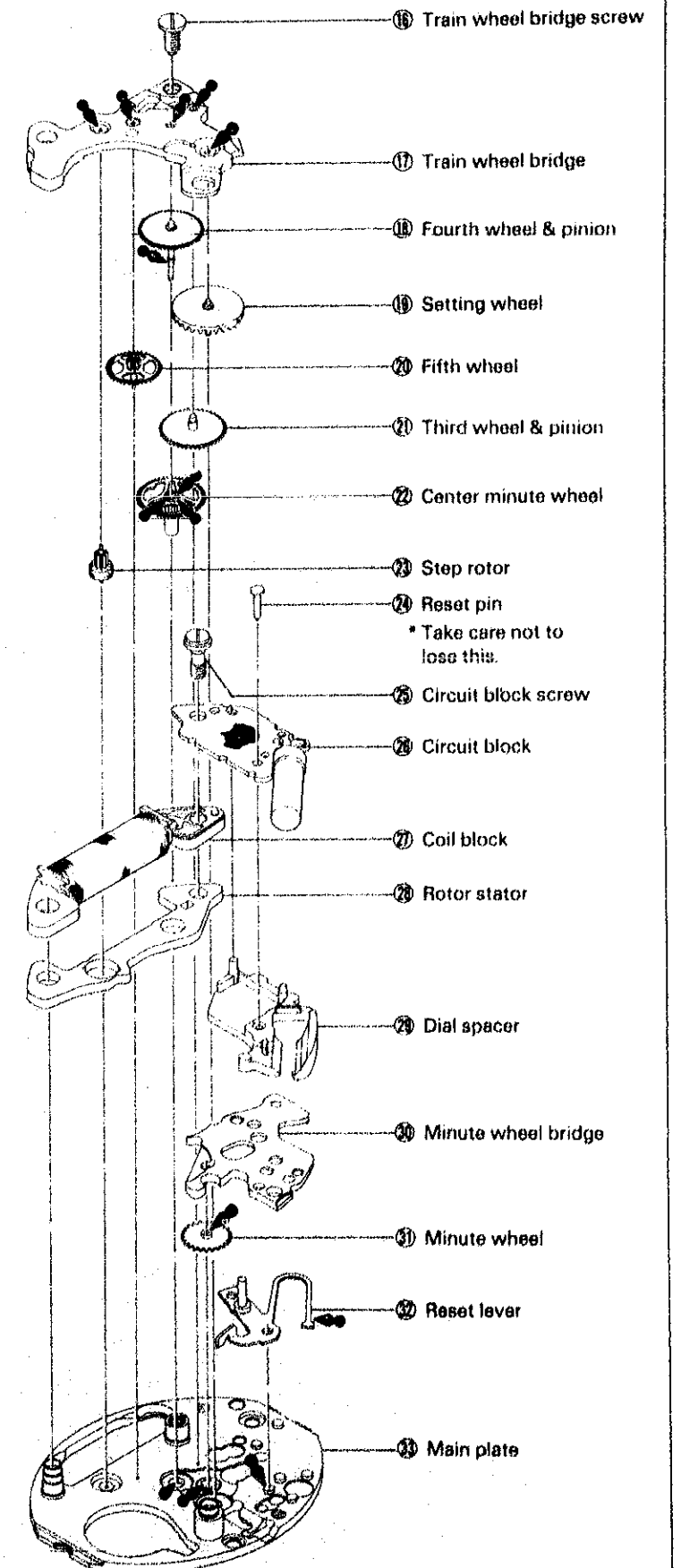
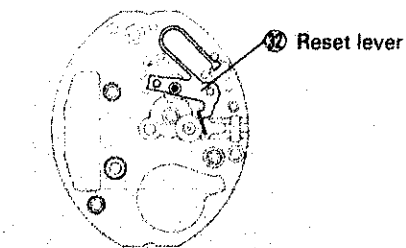

IV. CHECKING AND ADJUSTMENT

1. Structure of circuit block

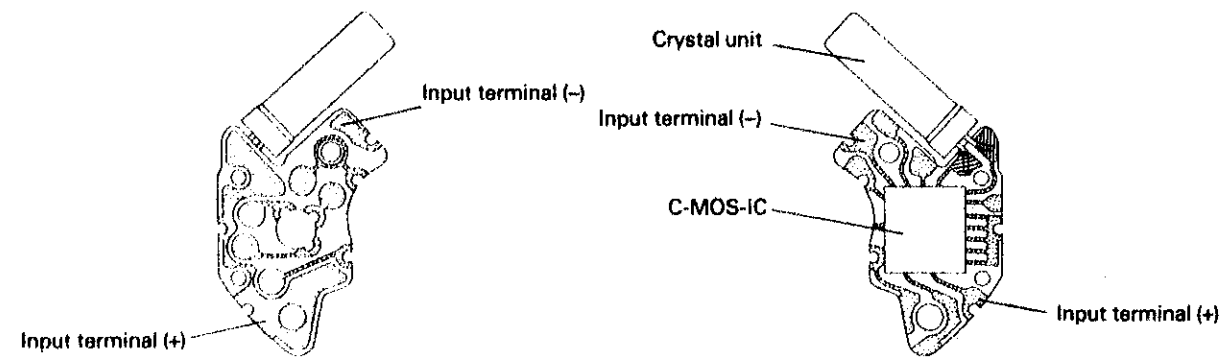

2. Procedure for checking and adjustment

- This section only gives the checking and adjustment procedure which is exclusive for this cal. V233A.
For the normal checking and adjustment, refer to the "TECHNICAL GUIDE GENERAL INSTRUCTION, Anglogue Quartz".

OUTPUT SIGNAL

1. Use the Quartz Tester.
 2. Turn the measuring gate selection to "10-second" gate.
- NOTE:**
Checking should be made with the crown set to normal position.

Result:
Output signal: Normal
No output signal: Defective
Check the coil block.

BATTERY VOLTAGE

- Use the SEIKO Digital Multi Tester S-840A
Range to be used: DC V
- NOTE:**
Before measuring, short circuit the probes and confirm that the tester reads AUTO 00.0 mV or AUTO 00.1 mV.

Result:
More than 1.57V: Normal
Less than 1.57V: Defective
Replace the battery.

COIL BLOCK

- Check the coil block for broken wire and short circuit using the SEIKO Digital Multi Tester S-840A.
Range to be used: Ω

Result:
3.0k Ω ~ 3.4k Ω : Normal
{ Less than 3.0k Ω (short circuit): Defective
More than 3.4k Ω (broken wire): Defective
Replace the coil block with a new one

CURRENT CONSUMPTION

Use the SEIKO Digital Multi-Tester S-840A (with Multi Adaptor MA-40)
Range to be used: μ A

Red probe: Battery connection (+)
Black probe: Battery connection (-)

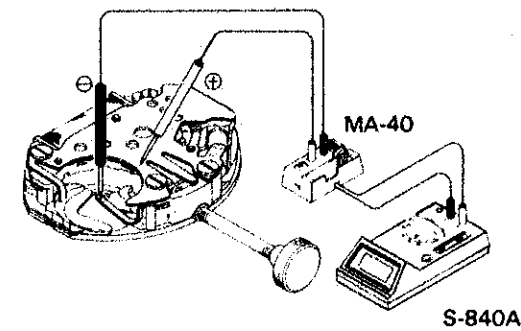

Result:
Less than 1.1 μ A: Normal
More than 1.1 μ A: Defective
• When measuring, cover the C-MOS-IC with a black sheet.

V. PARTS LIST

Cal. V233 A	
PARTS NO.	PARTS NAME
125 089	Train wheel bridge
231 089	Third wheel & pinion
238 003	Guide pipe for winding stem
*241 089	Fourth wheel & pinion
*241 090	Fourth wheel & pinion
*241 116	Fourth wheel & pinion
261 024	Minute wheel
*270 072	Center minute wheel
*270 073	Center minute wheel
*270 116	Center minute wheel
*271 116	Hour wheel
*271 189	Hour wheel
*271 190	Hour wheel
281 013	Setting wheel
*351 134	Winding stem (φ80)
*351 135	Winding stem (φ90)
391 499	Train wheel setting lever
491 141	Dial washer
701 089	Fifth wheel & pinion
4000 499	Circuit block
4002 499	Coil block
4148 030	Step rotor
4225 067	Battery clamp
4239 499	Rotor stator
4270 061	Battery connection (-)
*4271 046	Battery connection (+)
4408 499	Dial spacer
4455 002	Reset lever
011 583	Upper hole jewel for step rotor
012 010	Battery clamp screw
012 064	Train wheel bridge screw
012 495	Circuit block screw
012 818	Screw for battery connection (+) (A)
012 819	Screw for battery connection (+) (B)
032 046	Tube for train wheel bridge (B)
032 047	Tube for train wheel bridge (A)
033 071	Reset pin
SEIKO TR521SW MAXELL SR521SW SONY EVEREADY 379	Battery

Remarks:

- * Fourth wheel & pinion, Center minute wheel, Hour wheel
There are three different types as specified below.

Combination:

*Type	Fourth wheel & pinion	Center minute wheel	Hour wheel
S	241 089	270 072	271 189
M	241 090	270 073	271 190
L	241 116	270 116	271 116

*Abbreviation S..... Short type
(Movement type) M..... Standard type
L..... Long type

- * Winding stem
The type of winding stem is determined based on the design of case. Check the case number and refer to "Casing Parts Catalogue" to choose a corresponding winding stem.

- * BATTERY CONNECTION (+) FOR PULSAR WATCHES
4271045 (Pulsar marking)